

A-A ( 1:40 )

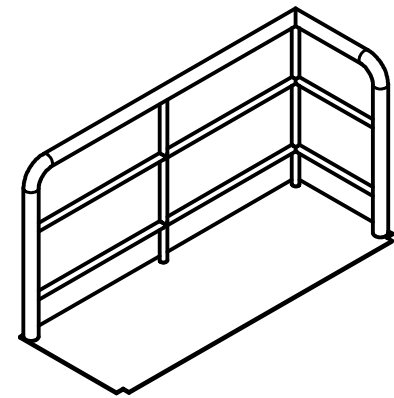

DISEÑO: Grimaldo Michelle y Lopez Jean	MATERIAL: Acero Galvanizado	<h1>UCV</h1>
DIBUJO: Grimaldo Michelle y Lopez Jean	CANTIDAD: 1	
REVISADO: 22/05/2013	ESCALA: 1:40	
APROBADO: 24/05/2013		
NOTAS:		TÍTULO: PLATAFORMA OPERARIO
		HOJA 1/1
		UNIVERSIDAD CENTRAL DE VENEZUELA - FACULTAD DE INGENIERÍA - EIM

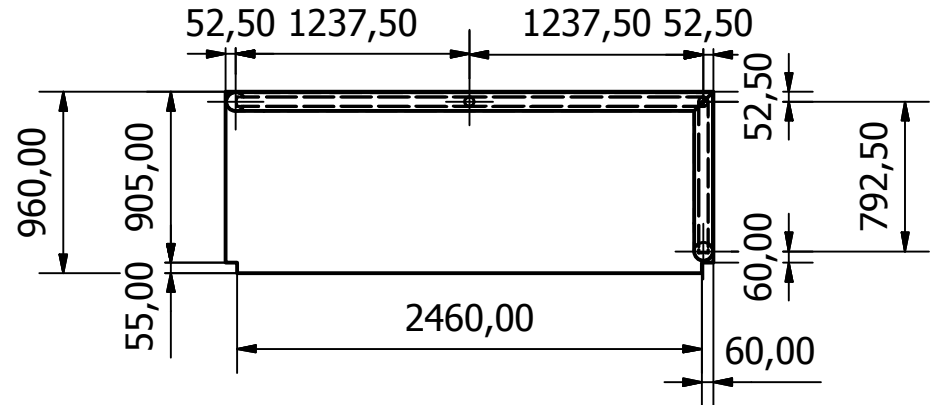
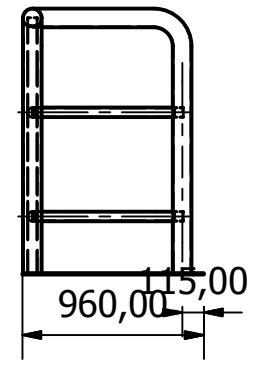
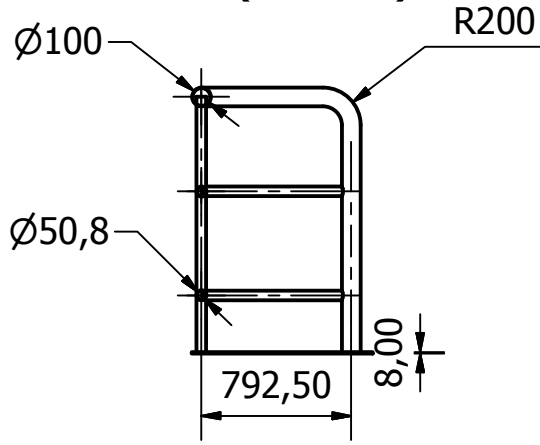
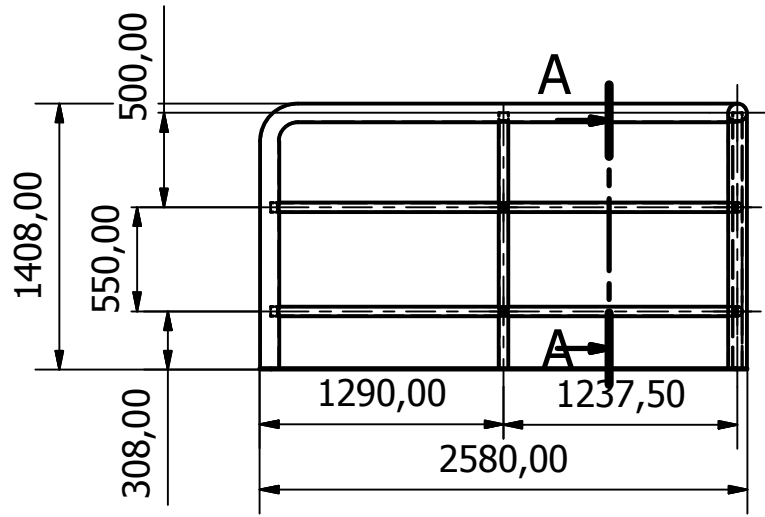
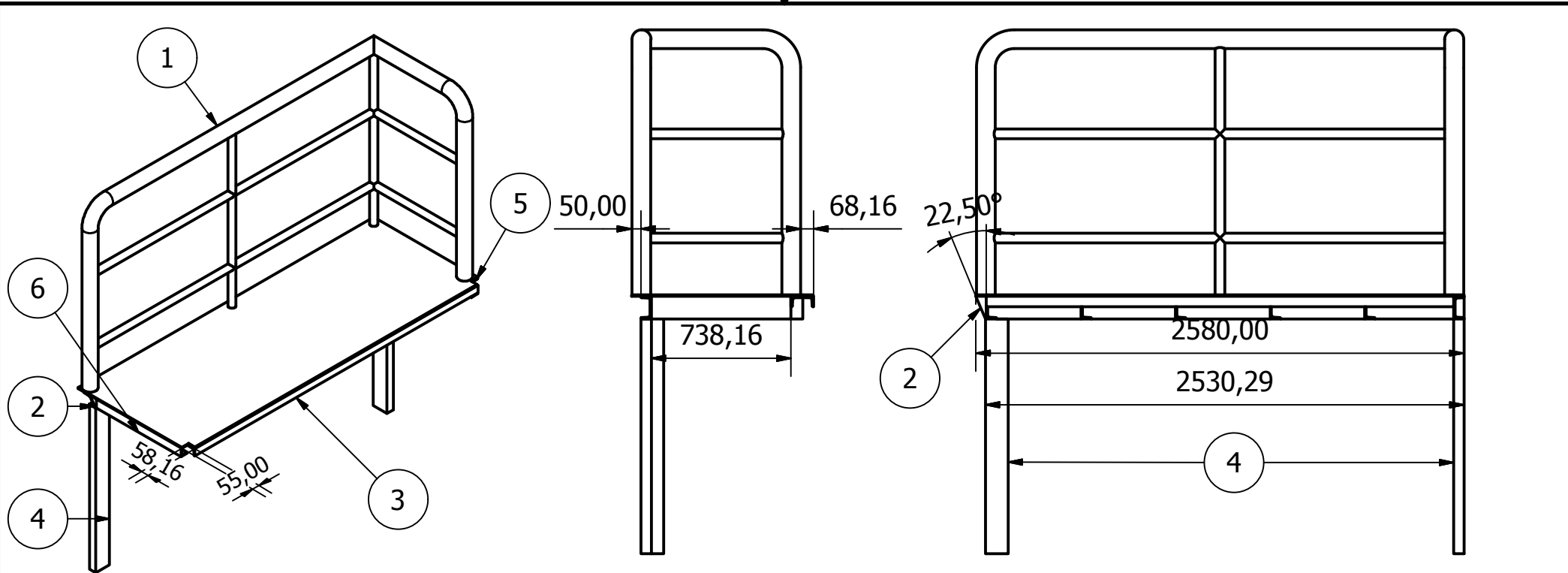

PRODUCED BY AN AUTODESK EDUCATIONAL PRODUCT

PRODUCED BY AN AUTODESK EDUCATIONAL PRODUCT

PARTS LIST		
ELEMENTO N°	NOMBRE	CANTIDAD
1	Plataforma op.	1
2	DIN1026 - U 120 - 2580	1
3	DIN1026 - U 120 - 2525	1
4	DIN1026 - U 120 - 1240	2
5	DIN1026 - U 120 - 800	1
6	DIN1026 - U 120 - 738,16	5

DISEÑO: Grimaldo Michelle y Lopez Jean	MATERIAL: Acero Galvanizado	<h1>UCV</h1>
DIBUJO: Grimaldo Michelle y Lopez Jean	CANTIDAD: 1	
REVISADO: 22/05/2013	ESCALA: 1:30	
APROBADO: 24/05/2013		
<b>NOTAS:</b>		TÍTULO: PLATAFORMA OPERARIO COMPL.
La lámina de la plat. sera texturizada		HOJA 1/1
UNIVERSIDAD CENTRAL DE VENEZUELA - FACULTAD DE INGENIERÍA - EIM		