

Apéndices

Apéndice 1

Constantes c y m para flujo cruzado (Incropera, F. 1996)

Configuración	$Re_{D, \text{máx}}$	C	m
Alineado	$10 - 10^2$	0.80	0.40
Escalonado	$10 - 10^2$	0.90	0.40
Alineado	$10^2 - 10^3$	Se aproxima como un cilindro único (aislado)	
Escalonado	$10^2 - 10^3$		
Alineado ($S_T/S_L > 0.7$) ^a	$10^3 \rightarrow 2 \times 10^5$	0.27	0.63
Escalonado ($S_T/S_L < 2$)	$10^3 - 2 \times 10^5$	$0.35(S_T/S_L)^{1/5}$	0.60
Escalonado ($S_T/S_L > 2$)	$10^3 - 2 \times 10^5$	0.40	0.60
Alineado	$2 \times 10^5 - 2 \times 10^6$	0.021	0.84
Escalonado	$2 \times 10^5 - 2 \times 10^6$	0.022	0.84

^aPara $S_T/S_L < 0.7$, la transferencia de calor es ineficiente y los tubos alineados no se deben usar.

Apéndice 2

Factor de corrección C_2 (Incropera, F. 1996)

N_L	1	2	3	4	5	7	10	13	16
Alineado	0.70	0.80	0.86	0.90	0.92	0.95	0.97	0.98	0.99
Escalonado	0.64	0.76	0.84	0.89	0.92	0.95	0.97	0.98	0.99

Apéndice 3

Factor de fricción f y χ para arreglo de haces de tubos escalonados (Incropera, F. 1996)

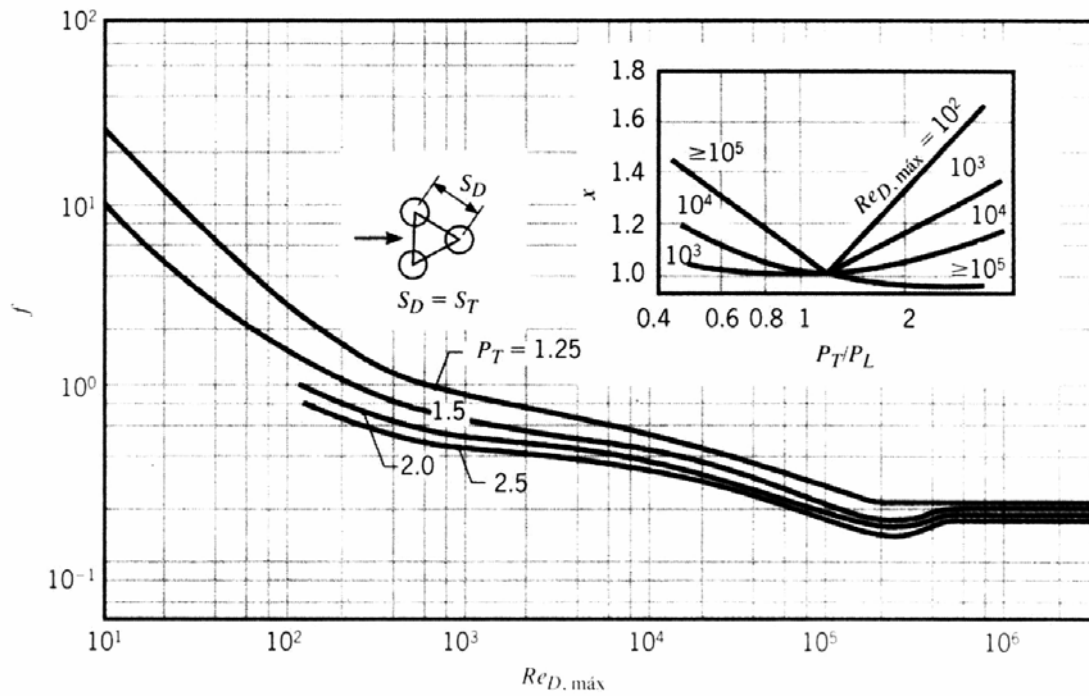

Apéndice 4**Valores típicos del coeficiente de transferencia de calor por convección (Incropera, F. 1996)**

Proceso	h (W/m² · K)
Convección libre	
Gases	2-25
Líquidos	50-1000
Convección forzada	
Gases	25-250
Líquidos	50-20,000
Convección con cambio de fase	
Ebullición o condensación	2500-100,000

Apéndice 5
Propiedades termofísicas de sólidos metálicos
(incropera, F. 1996)

Composición	Punto de fusión (K)	Propiedades a 300 K					Propiedades a varias temperaturas (K)						
		ρ (kg/m ³)	c_p (J/kg · K)	k (W/m · K)	$\alpha \cdot 10^6$ (m ² /s)	k (W/m · K) (c_p (J/kg · K))							
						400	600	800	1000	1200	1500	2000	2500
Acero puro	1810	7870	447	80.2	23.1	134	94.0	69.5	54.7	43.3	32.8	28.3	32.1
Aceros al carbón													
Carbón ordinario (Mn \leq 1%, Si \leq 0.1%)		7854	434	60.5	17.7	216	384	490	574	680	975	609	654
AISI 1010		7832	434	63.9	18.8			487	559	685	1168		
Carbón-silicio (Mn \leq 1%, 0.1% < Si \leq 0.6%)		7817	446	51.9	14.9			49.8	44.0	37.4	29.3		
Carbón-manganeso-silicio (1% < Mn \leq 1.65%, 0.1% < Si \leq 0.6%)		8131	434	41.0	11.6			42.2	39.7	35.0	27.6		
Aceros con cromo (bajo)													
1Cr-1Mo-Si (0.18% C, 0.65% Cr, 0.23% Mo, 0.6% Si)		7822	444	37.7	10.9			38.2	36.7	33.3	26.9		
1Cr-1Mo (0.16% C, 1% Cr, 0.54% Mo, 0.39% Si)		7858	442	42.3	12.2			42.0	39.1	34.5	27.4		
1Cr-V (0.2% C, 1.02% Cr, 0.15% V)		7836	443	48.9	14.1			49.2	575	688	969		
Aceros inoxidables													
AISI 302		8055	480	15.1	3.91			17.3	20.0	22.8	25.4		
AISI 304	1670	7900	477	14.9	3.95	9.2	12.6	51.2	55.9	58.5	60.6	28.0	31.7
AISI 316		8238	468	13.4	3.48	27.2	40.2	16.6	19.8	22.6	25.4	640	682
AISI 347		7978	480	14.2	3.71			51.5	55.7	58.2	61.1		
								50.4	55.0	57.6	60.2		
								15.8	18.9	21.9	24.7		
								51.3	55.9	58.5	60.6		

Apéndice 6
Propiedades de los materiales de construcción
(Incropera, F. 1996)

Materiales estructurales de construcción

Descripción/composición	Propiedades típicas a 300 K		
	Densidad, ρ (kg/m ³)	Conductividad térmica, k (W/m · K)	Calor específico, c_p (J/kg · K)
Tableros de construcción			
Tablero de asbesto-cemento	1920	0.58	—
Tablero de yeso	800	0.17	—
Madera contraplacada	545	0.12	1215
Revestimiento, densidad regular	290	0.055	1300
Teja acústica	290	0.058	1340
Madera prensada	640	0.094	1170
Madera prensada, alta densidad	1010	0.15	1380
Tablero de partículas, baja densidad	590	0.078	1300
Tablero de partículas, alta densidad	1000	0.170	1300
Maderas			
Maderas duras (roble, arce)	720	0.16	1255
Maderas suaves (abeto, pino)	510	0.12	1380
Materiales de mampostería			
Mortero de cemento	1860	0.72	780
Ladrillo, común	1920	0.72	835
Ladrillo, frente	2083	1.3	—
Teja de arcilla, hueca			
1 celda de profundidad, 10 cm de espesor	—	0.52	—
3 celdas de profundidad, 30 cm de espesor	—	0.69	—
Bloque de concreto, 3 núcleos ovales			
Arena/grava, 20 cm de espesor	—	1.0	—
Ceniza agregada, 20 cm de espesor	—	0.67	—
Bloque de concreto, núcleo rectangular			
2 núcleos, 20 cm de espesor	—	1.1	—
El mismo con núcleos llenos	—	0.60	—
Materiales de emplasto			
Emplasto de cemento, arena agregada	1860	0.72	—
Revoque de yeso, arena agregada	1680	0.22	1085
Revoque de eso, vermiculita agregada	720	0.25	—

Apéndice 7
Propiedades térmicas del aire
(Incropera, F. 1996)

T (K)	ρ (kg/m ³)	c_p (kJ/kg · K)	$\mu \cdot 10^7$ (N · s/m ²)	$\nu \cdot 10^6$ (m ² /s)	$k \cdot 10^3$ (W/m · K)	$\alpha \cdot 10^6$ (m ² /s)	Pr
Aire							
100	3.5562	1.032	71.1	2.00	9.34	2.54	0.786
150	2.3364	1.012	103.4	4.426	13.8	5.84	0.758
200	1.7458	1.007	132.5	7.590	18.1	10.3	0.737
250	1.3947	1.006	159.6	11.44	22.3	15.9	0.720
300	1.1614	1.007	184.6	15.89	26.3	22.5	0.707
350	0.9950	1.009	208.2	20.92	30.0	29.9	0.700
400	0.8711	1.014	230.1	26.41	33.8	38.3	0.690
450	0.7740	1.021	250.7	32.39	37.3	47.2	0.686
500	0.6964	1.030	270.1	38.79	40.7	56.7	0.684
550	0.6329	1.040	288.4	45.57	43.9	66.7	0.683
600	0.5804	1.051	305.8	52.69	46.9	76.9	0.685
650	0.5356	1.063	322.5	60.21	49.7	87.3	0.690
700	0.4975	1.075	338.8	68.10	52.4	98.0	0.695
750	0.4643	1.087	354.6	76.37	54.9	109	0.702
800	0.4354	1.099	369.8	84.93	57.3	120	0.709
850	0.4097	1.110	384.3	93.80	59.6	131	0.716
900	0.3868	1.121	398.1	102.9	62.0	143	0.720
950	0.3666	1.131	411.3	112.2	64.3	155	0.723
1000	0.3482	1.141	424.4	121.9	66.7	168	0.726
1100	0.3166	1.159	449.0	141.8	71.5	195	0.728
1200	0.2902	1.175	473.0	162.9	76.3	224	0.728
1300	0.2679	1.189	496.0	185.1	82	238	0.719
1400	0.2488	1.207	530	213	91	303	0.703
1500	0.2322	1.230	557	240	100	350	0.685
1600	0.2177	1.248	584	268	106	390	0.688
1700	0.2049	1.267	611	298	113	435	0.685
1800	0.1935	1.286	637	329	120	482	0.683
1900	0.1833	1.307	663	362	128	534	0.677
2000	0.1741	1.337	689	396	137	589	0.672
2100	0.1658	1.372	715	431	147	646	0.667
2200	0.1582	1.417	740	468	160	714	0.655
2300	0.1513	1.478	766	506	175	783	0.647
2400	0.1448	1.558	792	547	196	869	0.630
2500	0.1389	1.665	818	589	222	960	0.613
3000	0.1135	2.726	955	841	486	1570	0.536
Amoniaco (NH₃)							
300	0.6894	2.158	101.5	14.7	24.7	16.6	0.887
320	0.6448	2.170	109	16.9	27.2	19.4	0.870
340	0.6059	2.192	116.5	19.2	29.3	22.1	0.872
360	0.5716	2.221	124	21.7	31.6	24.9	0.872
380	0.5410	2.254	131	24.2	34.0	27.9	0.869

Anexos

Anexo 1
Sistema automático para la aplicación de
recubrimientos por electrostática. (Empresa
Unialambre).



Anexo 2

Disposición acostada de puertas en el riel de transporte. (Empresa Viso)



Anexo 3a
Datos técnicos de la pintura. (AENOR)

BENQUIM, C.A.

ZONA IND. CARABOBO TRANS. 8 C.C. LAGO DE VALENCIA, 4

VALENCIA-VENEZUELA

O.K.
F-013.40
4-12

<i>Código de Producto</i>	<i>Descripción del recubrimiento en polvo</i>	
H3-0000/T	BCO. NIEVE.85 B (RH-263)	
<i>Lote</i>	<i>Fecha de fabricación</i>	<i>Cantidad envío</i>
650904	07/10/2002	4699

DATOS TECNICOS DEL PRODUCTO

<i>Descripción de la prueba</i>	<i>Valor encontrado</i>	<i>Especificaciones</i>		<i>Método de ensayo</i>
		<i>inferior</i>	<i>superior</i>	
ADHERENCIA CORTE REJILLA	100,00	100,00	100,00	ISO 2409
BRILLO ANGULO DE 60°	93,31	85,00	95,00	ISO 2813
DUREZA PERSOZ.	250,00	200,00	350,00	ISO 1522
EMBU TION ERICHSEN	6,91	7,00	10,00	ISO 1520
ESPELOR DEL RECUBRIMIENTO	78,57	60,00	80,00	LV-111
ESPELOR SUSTRATO DE ACERO	1,00	1,00	1,00	LV-100
ESTUFADO PROBETA A 180°C	15,00	15,00	15,00	ESTUFA
GRANULOMETRIA %< 10µ	6,93	0,00	7,00	LV-107
GRANULOMETRIA %< 100µ	95,79	95,00	100,00	LV-107
GRANULOMETRIA MEDIA	46,59	40,00	47,00	LV-107
IMPACTO DIRECTO (1Kg, 12,5 mm.)	70,00	70,00	100,00	ECCA T5
IMPACTO INVERSO (1Kg, 12,5 mm.)	70,00	70,00	100,00	ECCA T5
NIVELACION DEL RECUBRIMIENTO	7,57	6,00	8,00	LV-106
PLEGADO CILINDRICO	4,55	5,00	5,00	ISO 1519

PLV-011/a

Anexo 3a

**Gráfica de prueba para el horno de la empresa
unialambre. (BENQUIM)**

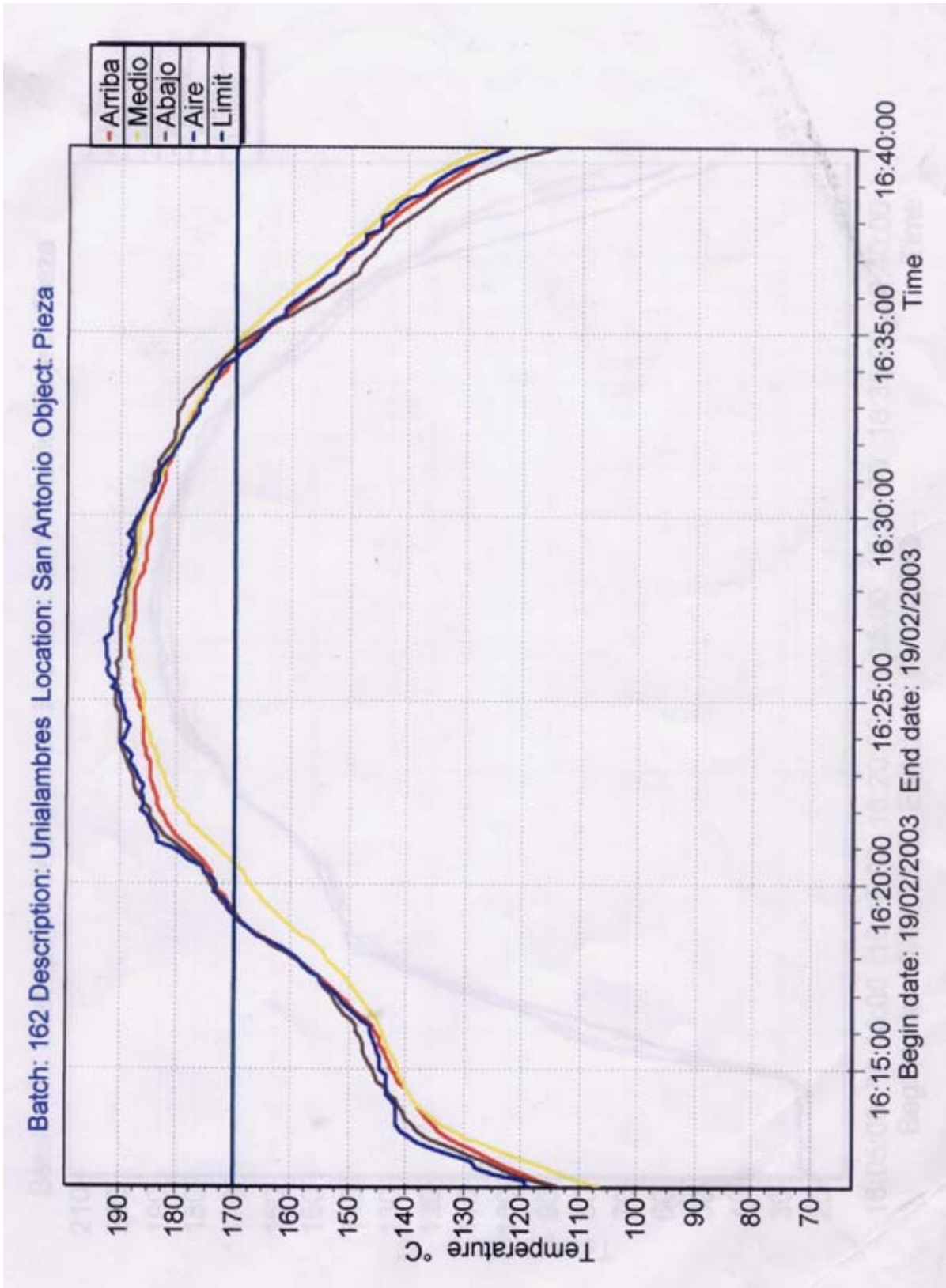

Anexo 4
Material aislante. (SONOTERMA C.A.)



SONOTERMA C.A.
FABRICA DE MATERIALES AISLANTES

M	MANTAS
	SONOLANA 1300

CERTIFICADO DE CALIDAD

SONOTERMA, C.A., certifica que este producto ha sido fabricado bajo las más estrictas medidas de control de calidad, y ha superado las pruebas de inspección y ensayo realizadas según la Norma ASTM - C 592 TIPO II, COVENIN 2023 y los procedimientos del sistema de gestión de la calidad de la empresa

En adición, SONOTERMA, C.A., certifica que este producto cumple con las propiedades físico - químicas pertinentes, bajo condiciones normales del almacenamiento y uso.

NUESTROS CONTROLES DE CALIDAD SON HOMOLOGADOS PERIODICAMENTE POR REPRESENTANTES AUTORIZADOS DE LA INDUSTRIA PETROLERA (INTEVEP) Y DE LA SIDERURGICA DEL ORINOCO (SIDOR).

IMPORTANTE ** IMPORTANTE *** IMPORTANTE**

El material amparado por este certificado debe ser cuidadosamente revisado por el cliente a su recepción, en especial en cuanto a su COLOR, el cual debe ser BLANCO con posibilidad de tener ligera tonalidad de verde claro.

Durante su elaboración se separa el 97,5% del componente de Oxido Ferroso presente en la materia prima de Basalto

Una coloración oscura indicaría un excesivo contenido de Oxido Ferroso en el material, el cual tiende a interactuar con la superficie de aplicación, acortando de esta forma la vida útil de la instalación.

**SONOTERMA, C.A.,
NO FABRICA NI GARANTIZA MATERIAL DE COLOR DIFERENTE AL NOMINAL.**

CONDUCTIVIDAD TERMICA

Valores máximos de la conductividad térmica para este material, según la norma ASTM C-592:

°C	°F	W / m.K	Btu*in / h*ft ² *°F
38	100	0.043	0.30
93	200	0.052	0.36
149	300	0.061	0.42
260	500	0.091	0.63

**MANTAS
TIPO II**

SONOTERMA, C.A.
CONTROL DE CALIDAD

Anexo 5
Costo de los calentadores de aire.
(Los autores).

Estudio económico

Intercambiador en acero al carbon con hogar de llama en acero inoxidable

cant	descripción	precio unit	total
42	tubos 2" hierro negro (m)	8.800,0	369.600,0
2	láminas hierro negro (4mm)	96.000,0	192.000,0
1	lámina acero inoxidable 3mm (1x2)	227.500,0	227.500,0
60	tornillos M10 con tuerca y arandelas (8.8)	1.200,0	72.000,0
20	M.O. (mano de obra en horas) diseño y planificación	20.000,0	400.000,0
1	Corte	12.000,0	12.000,0
3	troquelacion	30.000,0	90.000,0
1	doblador	12.000,0	12.000,0
30	herreria	12.000,0	360.000,0
30	soldadura	20.000,0	600.000,0

Costo total 2.335.100,0

Estudio económico

Intercambiador en acero inoxidable

cant	descripción	precio unit	total
42	tubos 2" inoxidable (m)	43.500,0	1.827.000,0
3	lámina acero inoxidable 3mm (1x2)	227.500,0	682.500,0
60	tornillos M10 con tuerca y arandelas (8.8)	3.750,0	225.000,0
20	M.O. (mano de obra en horas) diseño y planificación	20.000,0	400.000,0
1	Corte	24.000,0	24.000,0
3	troquelacion	60.000,0	180.000,0
1	doblador	12.000,0	12.000,0
30	herreria	18.000,0	540.000,0
30	soldadura	55.000,0	1.650.000,0

Costo total 5.540.500,0

Anexo 6
Características del quemador. (WEISHAUPT)

2.2 Arbeitsfelder

Typ WG10../1-A – einstufig

mbar	Brennertyp	WG10../1-A, LN	Mischeinrichtung
	Flammkopf	WG10/1	"Auf" —
	Leistung kW	12 - 50	"Zu" —

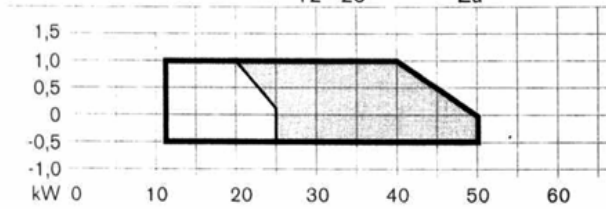

Typ WG10../1-A – gleitend-zweistufig

mbar	Brennertyp	WG10../1-A, LN	Mischeinrichtung
	Flammkopf	WG10/1	"Auf" —
	Leistung kW	12 - 50	"Zu" —

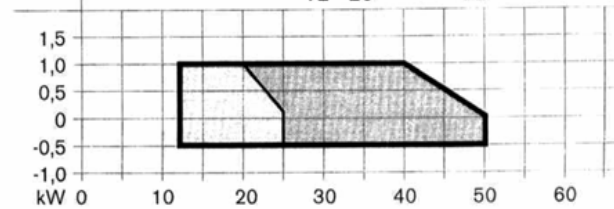

Typ WG20../0-A – einstufig

mbar	Brennertyp	WG20../0-A, LN	Mischeinrichtung
	Flammkopf	WG20/0	"Auf" —
	Leistung kW	30 - 90	"Zu" —

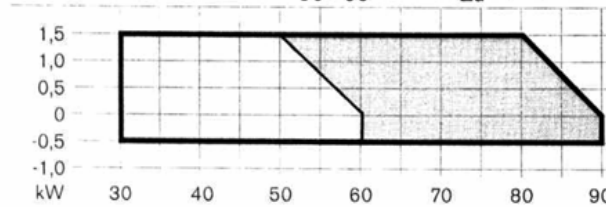

Typ WG20../0-A – gleitend-zweistufig

mbar	Brennertyp	WG20../0-A, LN	Mischeinrichtung
	Flammkopf	WG20/0	"Auf" —
	Leistung kW	25 - 90	"Zu" —

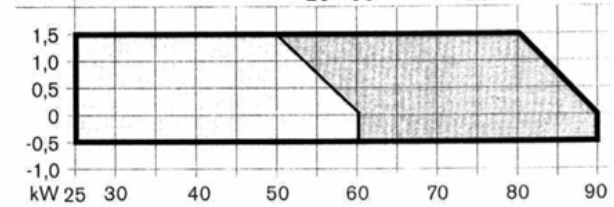

Typ WG20../1-A – einstufig

mbar	Brennertyp	WG20../1-A, LN	Mischeinrichtung
	Flammkopf	WG20/1	"Auf" —
	Leistung kW	50 - 160	"Zu" —

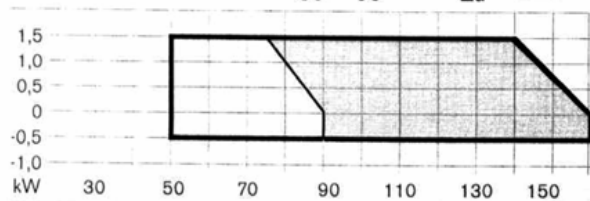

Typ WG20../1-A – gleitend-zweistufig

mbar	Brennertyp	WG20../1-A, LN	Mischeinrichtung
	Flammkopf	WG20/1	"Auf" —
	Leistung kW	30 - 160	"Zu" —

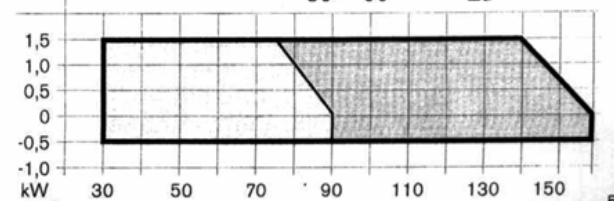

3.5 Brennerabmessungen

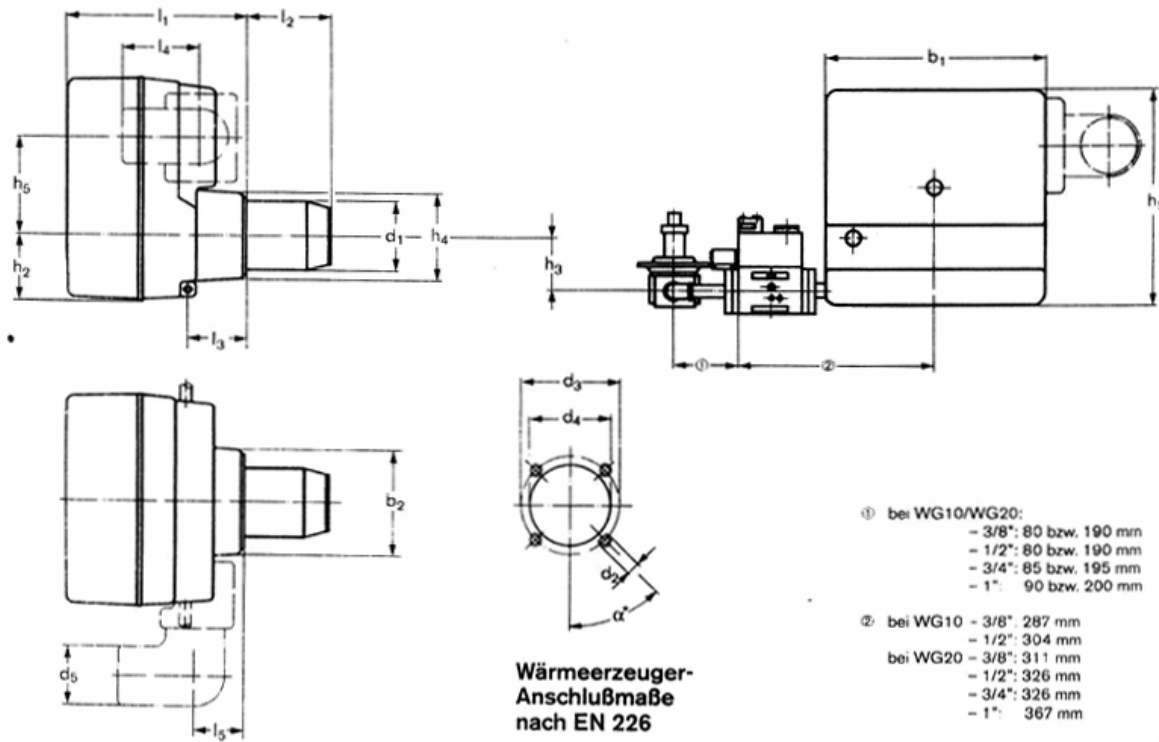

Maße ca. mm	l ₁	l ₂	l ₃	l ₄	l ₅	b ₁	b ₂	b ₃	h ₁	h ₂	h ₃	h ₄	h ₅	d ₁	d ₂	d ₃	d ₄	d ₅	α°
WG10../1-A	229	131	73	100	55	300	150	240	320	95	72	140	146	90	M8	130-150	95	70	45°
WG20../0-A	305	145	100	121	73	370	195	300	390	115	92	155	176	108	M8	150-170	110	100	45°
WG20../1-A	305	145	100	121	73	370	195	300	390	115	92	155	176	120	M8	150-170	130	100	45°

Anexo 7
Planos del calentador de aire.

Anexo 8
Características del ventilador. (FREDIVE C.A.)

VERSATILES POSICIONES

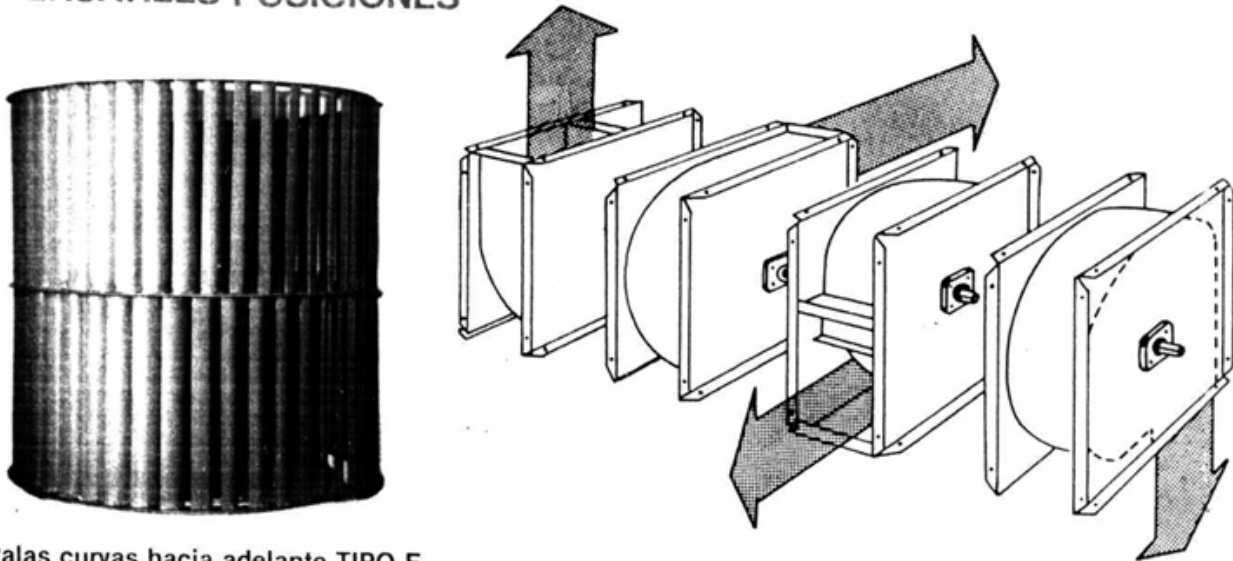

Palas curvas hacia adelante TIPO F

Las palas y los discos centrales son fabricadas por medio de troqueles, asegurando una rigurosa uniformidad de todas las piezas. Estas ruedas son recomendadas para ventilación forzada y aire acondicionado. Remueven grandes cantidades de aire contra medianas pérdidas de presión. Son sumamente silenciosas y trabajan a bajas revoluciones.

Vienen en tamaños desde 8 hasta 15 pulgadas y se fabrican en simple y doble entrada.

ROTACION Y DESCARGA

POSICION DEL MOTOR

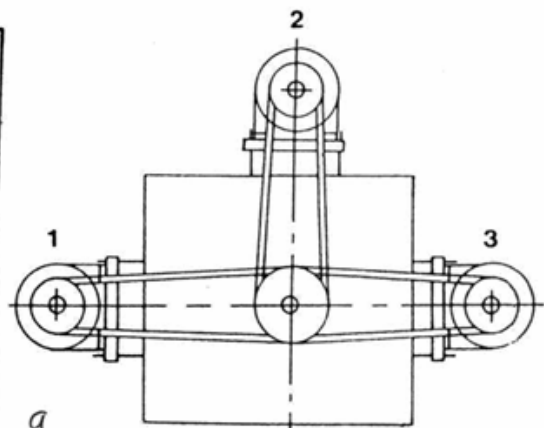
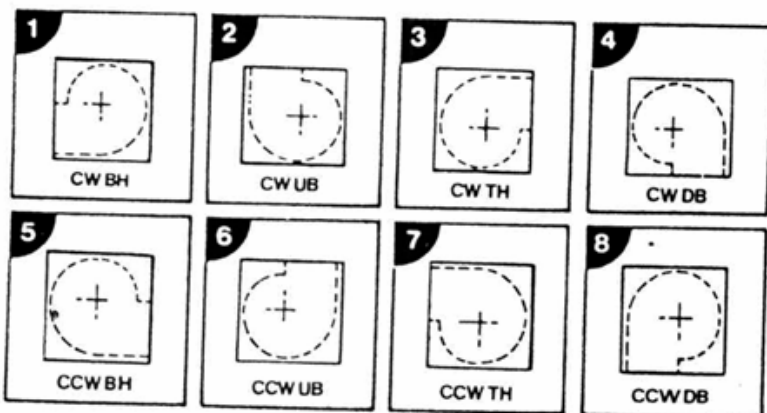

EL SENTIDO DE ROTACION SE DETERMINA POR EL LADO DE LA TRANSMISION

VENTILADOR MODELO SF12

RPM	HP	PCM CONTRA PRESION ESTATICA EN PULGADAS								
		0	1/8	1/4	1/2	3/4	1	1½	2	2½
600	1/2	900	800	700						
900	1/2	1300	1250	1150	900	700				
1200	3/4	1800	1750	1700	1600	1400	1300			
1500	3/4	2200	2100	2000	1950	1850	1750	1650	1600	1550
1800	1	3000	2800	2750	2700	2650	2600	2400	2200	2000

RPM	HP	M³/MIN. CONTRA PRESION EN M/M								
		0	3	6	12	18	25	38	50	62
600	1/2	25.3	22.5	19.7						
900	1/2	36.5	35.0	32.3	25.3	19.7				
1200	3/4	50.5	49.0	47.8	45.0	39.3	36.5			
1500	3/4	61.8	59.0	56.2	54.8	52.0	49.2	46.4	45.0	43.5
1800	1	84.3	78.7	77.3	75.8	74.4	73.0	67.4	61.8	56.2

9

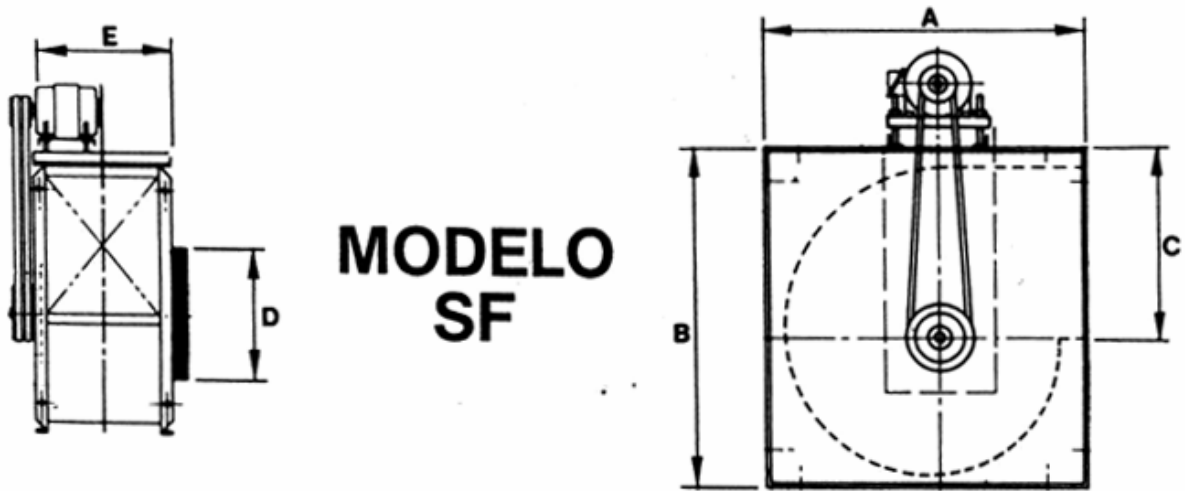

**MODELO
SF**

**MEDIDAS CONSTRUCTIVAS
EN MILIMETROS**

MODELO	A	B	C	D	E
8	385	375	210	160	115
10	450	450	255	210	144
12	505	530	305	255	170

NOTA: Todas las medidas son aproximadas.

Anexo 9a
Transportador tipo carrusel.

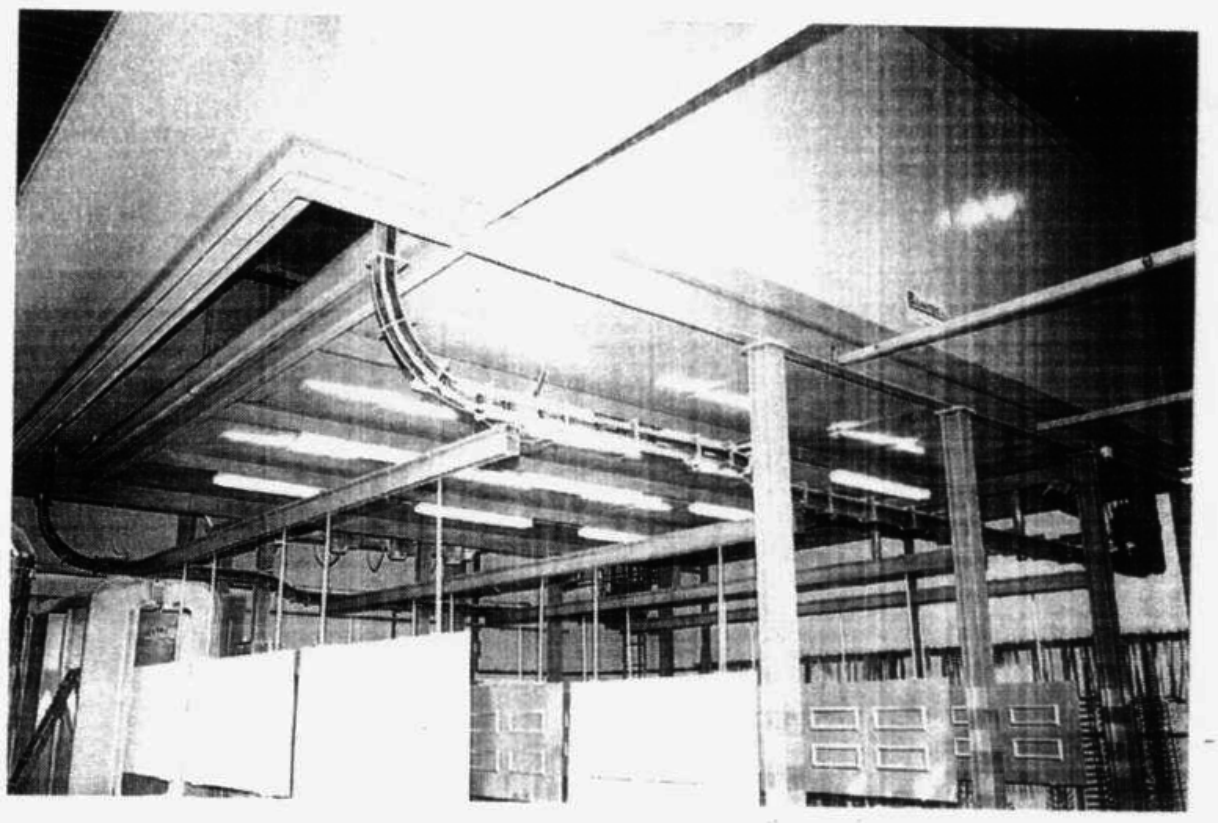

Anexo 9b
Transportador de riel lineal con secciones
transversales.

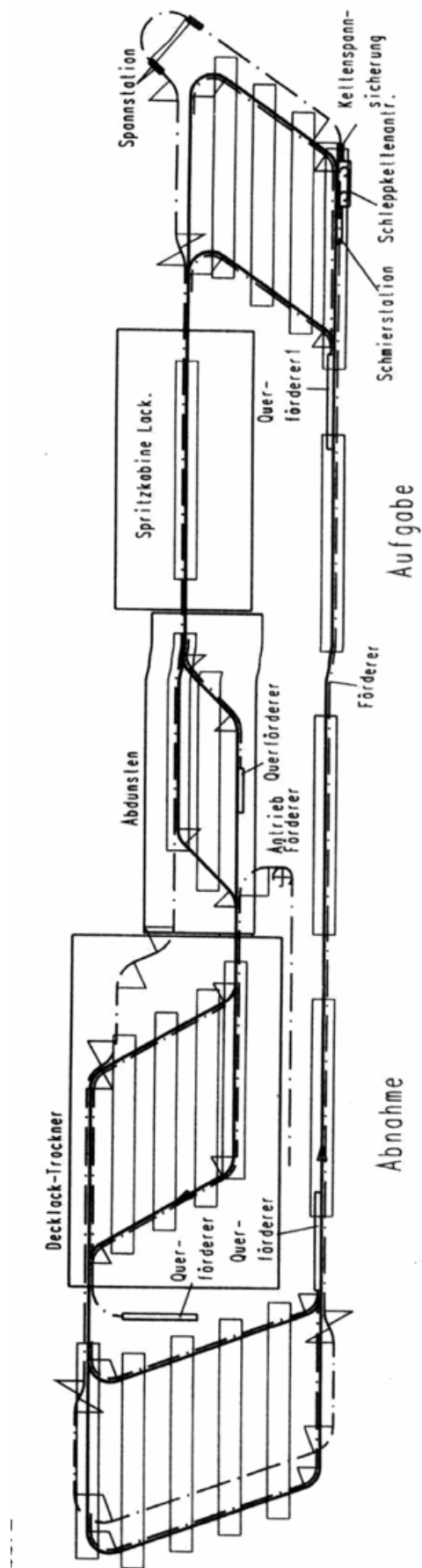

Anexo 10

Foto del carro de carga. (Los autores)



Anexo 11
Cadena seleccionada.



DOUBLE-PITCH ROLLER CHAIN

roller chain **A**

ANSI STANDARD Conveyor Series — Straight Edge Link Plates

Standard Roller Type

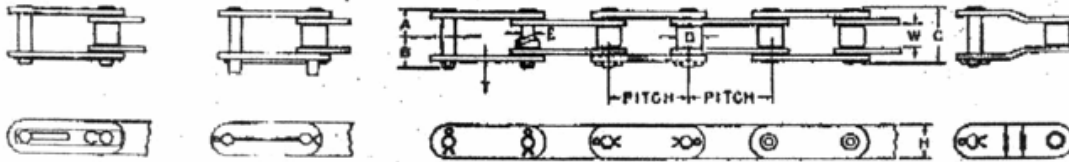
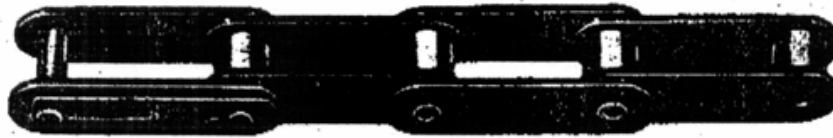

Carrier Roller Type

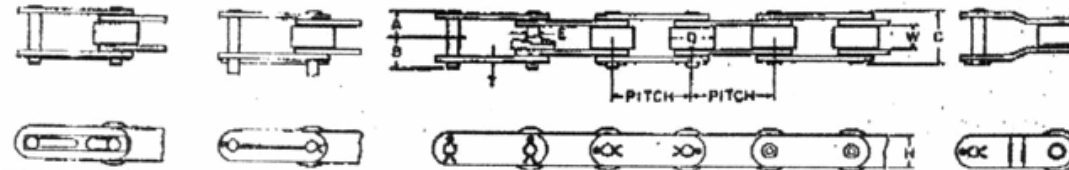

CONNECTING LINK
SPRING CLIP
TYPE
SCCLK

PIN LINK
LONG SINGLE COTTER
TYPE
LC

CONNECTING LINK
COTTER
TYPE
CCCLKCTP

PIN LINK
DOUBLE
COTTER
TYPE
DC

PIN LINK
RIVETED
TYPE
RV

OFFSET
LINK
TYPE
OLKCTP

Dimensions, Strengths, and Weights

Rex Chain No.	ANSI Standard	Pitch	Dimensions — Inches								Average Ultimate Strength, Lbs.	Minimum Ultimate Strength, ANSI Std. Lbs.	Average Weight Per Foot, Lbs.	Std. Type of Pin Link	Type of Connecting Link	
			Roller		From Pin Head to Center Line	From Pin End to Center Line	Over-All Width C		Link Plate							Pin Diam.
			Width	Diam.			Riv.	Cot.	Height	Thick-ness						
			W	D	A	B		T	F							
C-2040	1	3/8	0.312	1/8	1/8	1/2	1/8	1/2	0.060	0.150	3,900	3,125	0.34	Riv.	SCCLK	
C-2042	1	3/8	0.625	1/8	1/8	1/2	1/8	1/2	0.060	0.156	3,900	3,125	0.68	Riv.	SCCLK	
C-2050	1 1/4	3/8	0.400	1/8	1/8	1/2	1/8	1/2	0.080	0.200	6,300	4,882	0.58	Riv.	SCCLK	
C-2052	1 1/4	3/8	0.750	1/8	1/8	1/2	1/8	1/2	0.080	0.200	6,300	4,882	0.90	Riv.	SCCLK	
C-2060	1 1/2	1/2	0.489	3/8	1/8	1	1/8	1 1/2	0.094	0.234	8,500	7,030	0.83	Riv.	SCCLK	
C-2000H	1 1/2	1/2	0.469	1/2	1/2	1 1/2	1/2	1 1/2	0.125	0.234	8,500	7,030	1.00	Riv.	SCCLK	
C-2062H	1 1/2	1/2	0.875	1/2	1/2	1 1/2	1/2	1 1/2	0.125	0.234	8,500	7,030	1.48	Riv.	SCCLK	
C-2080H	2	3/8	0.625	1/8	1/8	1 1/2	1 1/2	1 1/2	0.156	0.312	14,500	12,500	1.6	DC	DC	
C-2082H	2	3/8	1.125	1/8	1/8	1 1/2	1 1/2	1 1/2	0.156	0.312	14,500	12,500	2.3	DC	DC	
C-2100H	2 1/2	3/8	0.750	1/8	1/8	1 1/2	1 1/2	1 1/2	0.187	0.374	24,000	19,530	2.5	DC	DC	
C2102H	2 1/2	1/2	1.562	1/8	1/8	1 1/2	1 1/2	1 1/2	0.187	0.374	24,000	19,530	4.0	DC	DC	
C-2120H	3	1	0.875	1/8	1/8	2 1/2	2 1/2	2 1/2	0.218	0.437	34,000	28,125	3.6	DC	DC	
C-2122H	3	1	1.750	1/8	1/8	2 1/2	2 1/2	2 1/2	0.218	0.437	34,000	28,125	5.7	DC	DC	
C-2160H	4	1 1/4	1.125	1/8	1/8	2 1/2	2 1/2	2 1/2	0.281	0.562	58,000	50,000	6.2	DC	DC	
C-2162H	4	1 1/4	2.250	1/8	1/8	2 1/2	2 1/2	2 1/2	0.281	0.562	58,000	50,000	9.3	DC	UC	

Anexo 12
Perfiles de rieles.

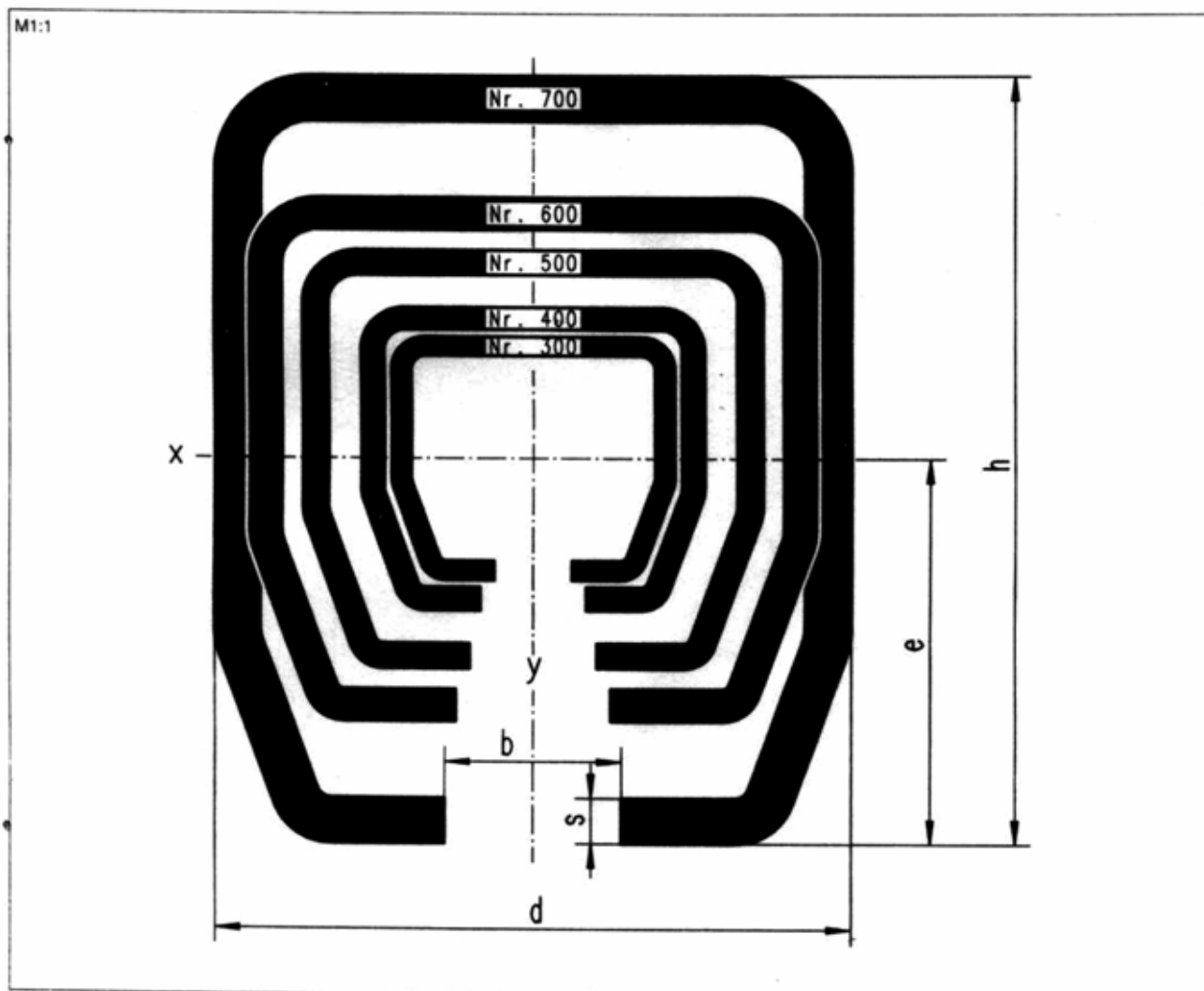

Oberstehende HELM-Laufschienenprofile Werkst. ST 37-2 stehen zur Verfügung. Diese Profile sind in Eisen blank oder galvanisch verzinkt, in Lagerlängen von ca. 6 m oder als Fixlängen lieferbar. Die Profile Nr. 300, 400 und Nr. 500 können auch in Edelstahl V2A (Werkstoff 4301) geliefert werden.

Da bei Pufferstrecken die Tragfähigkeit der Laufschiene oft überschritten wird, muß die Meterbelastung überprüft werden.

HELM-Profil	h mm	d mm	b mm	s mm	W _x cm ³	I _X cm ⁴	e mm	Gewicht kg/m	Tragkraft kg*
Nr. 300	35	40	11	2,75	2,52	5,02	19,9	2,52	100
Nr. 400	43,5	48,5	15	3,2	4,4	15,10	24,8	3,57	200
Nr. 500	60	65	18	3,6	10,07	34,08	33,8	5,63	500
Nr. 600	75	80	22	4,5	19,76	83,08	42	8,77	1000
Nr. 700	110	90	25	6,5	51,68	312,71	60,5	16,46	1600

*Tragfähigkeit pro Meter bei einem Aufhängeabstand von ca. 1 m

Anexo 13
Planos del transportador.

Anexo 14
Diagrama de funcionamiento del transportador.
(Los autores)

*DIAGRAMA DE FUNCIONAMIENTO
DEL CICLO DEL TRANSPORTE EN
EL HORNO.*

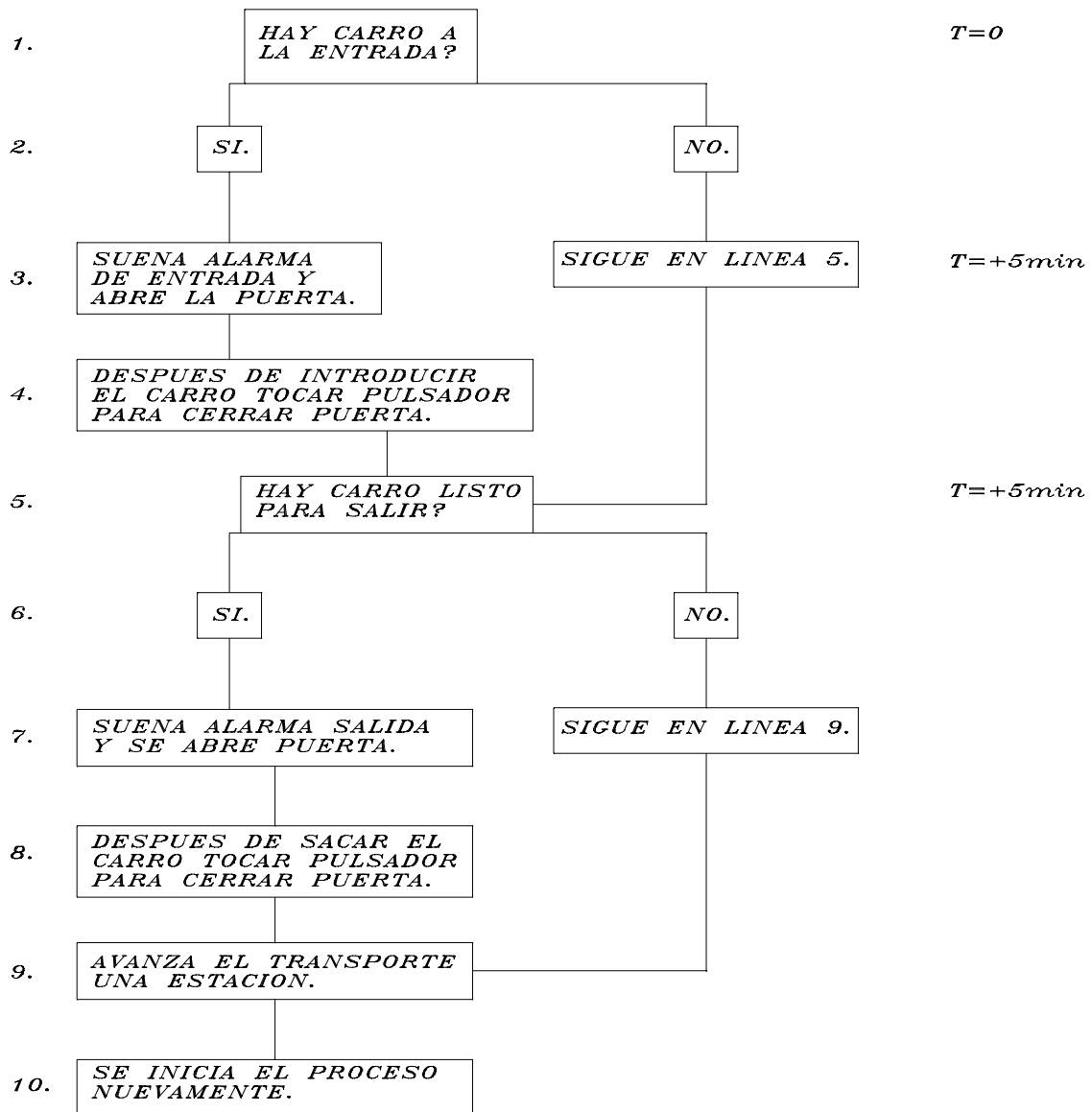

Anexo 3-15
Planos del horno.

Anexo 3-16

**Gráficas de prueba para el horno diseñado.
(BENQUIM)**

Compañía	Benquim, C.A.	Proceso	Horno de Curado	Impreso	24-04-2003
Lugar	Viso	Producto		Velocidad Línea	0,05 (m/min)

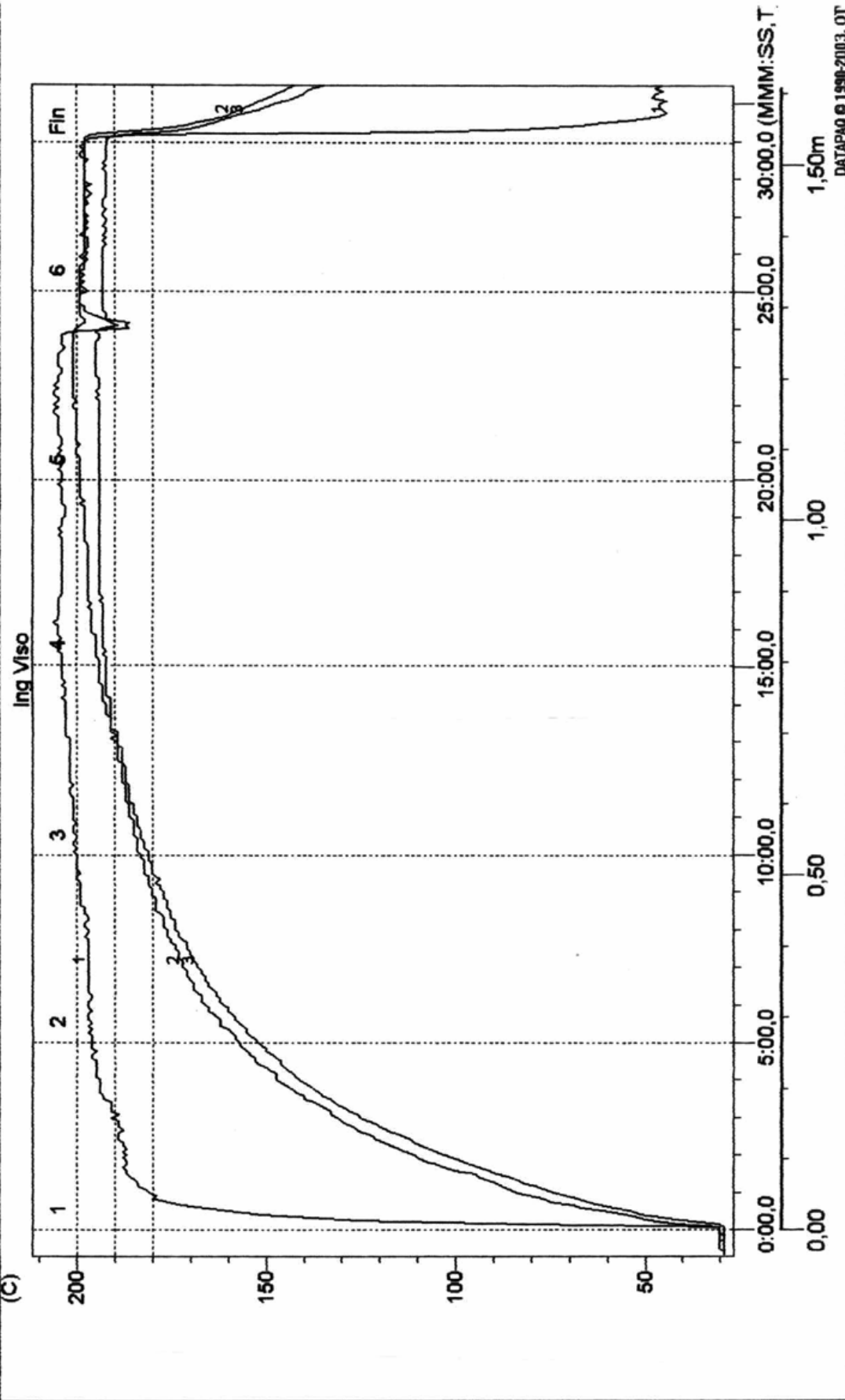

		DATAPAG © 1998-2003, OT					
		#1	#2	#3	#4	#5	#
Velocidad 0,05 (m/min)	Zona Superior	0	0	0	0	0	0
	Zona Inferior	0	0	0	0	0	0

	Por Encima	Alcanz	Por Encima	Alcanz	Por Encima	Alcanz
	200C	200C	190C	190C	180C	180C
Ambiente	14:35,0	9:20,0	25:50,0	3:00,0	28:20,0	0:50,0
Lamina Sup	3:20,0	20:40,0	16:05,0	13:05,0	20:25,0	8:55,0
Lamina Inf	0:00,0	***	15:45,0	13:20,0	19:45,0	9:30,0