

Deployable Structures

by

Carlos Henrique Hernandez Merchan

Licenciado en Quimica
Caracas, Venezuela
1984

SUBMITTED TO THE DEPARTMENT OF ARCHITECTURE
IN PARTIAL FULFILLMENT OF THE REQUIREMENTS
FOR THE DEGREE
MASTER OF SCIENCE IN ARCHITECTURE STUDIES
at the
MASSACHUSETTS INSTITUTE OF TECHNOLOGY

June, 1987

© Carlos Henrique Hernandez Merchan 1987

The author hereby grants to M.I.T.
permission to reproduce and to distribute publicly
copies of this thesis document in whole or in part

Signature of the Author

Carlos Henrique Hernandez Merchan
Department of Architecture
May 5, 1987

Certified by

Waclaw Piotr Zalewski
Professor of Structures
Dr. Tech. Sci.
Thesis Supervisor

Accepted by

Julian Beinart
Chairman
Department Committee for Graduate Students

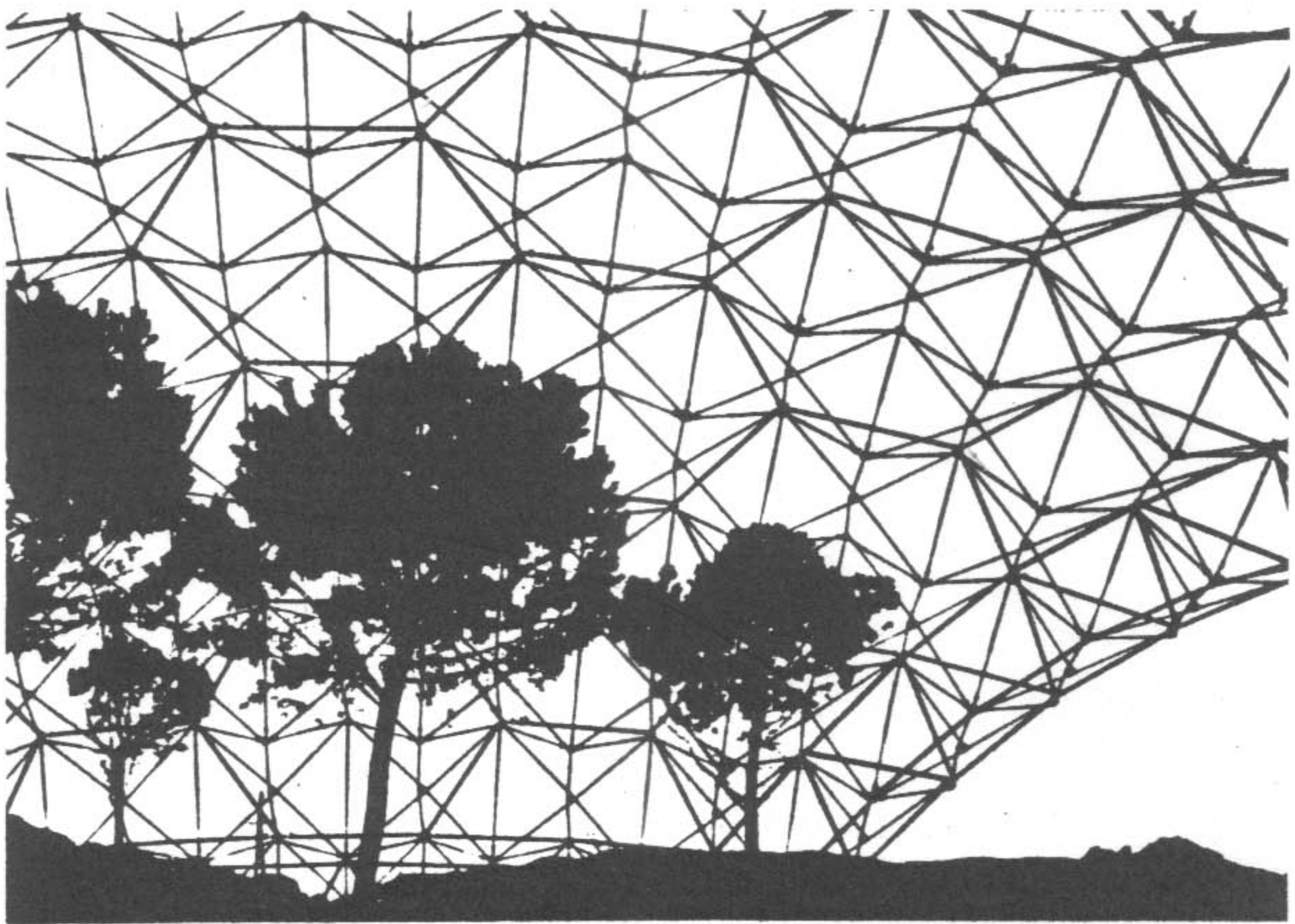

DEPLOYABLE STRUCTURES

This work is dedicated to :

***The People of Latinamerica, to whom
have died fighting, and whom are still
fighting again the imperialism, for a
better society.***

ACKNOWLEDGEMENTS : *I would like to thank Professor Waclaw Zalewski for his advice, encouragement and help during the realization of this thesis, and during these past two years at MIT, in which I have learned so much working with him. Deployable Structures would not have been possible without him.*

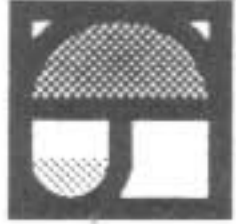

DEPLOYABLE STRUCTURES

ABSTRACT

by

Carlos Henrique Hernandez Merchan

Submitted to the Department of Architecture on May 5, 1987
in partial fulfillment of the requirements for the Degree of
Master in Science in architecture Studies

This thesis has the purpose of describing the meaning and applications of deployable structures (making emphasis in the scissor-hinged and sliding mechanisms.) and the development of new geometries, details, and mechanisms that make these systems buildable and useful for architectural applications.

A deployable structure is one that can be transformed, with the addition of an energy input, from a closed stage or compact configuration to a predetermined, stable expanded form.

Deployable structures are suitable in response to the following needs :

- a-** A situation in which there is a need to create enclosed or protected space for a short period of time and then move that space to another location for erection or storage.
- b-** Difficult access places, and/or lack of labor.
- c-** Special applications equipment and shelters for special equipment which can not be transported in full open size and needs to be erected in a very quick way.
- d-** Need to enclose space due to variable weather conditions.
- e-** Situations of high risk with elevated labor costs, hostile environments, costly transportation.
- f-** Construction aid.
- g-** As a construction method

There are many mechanisms which fall into the category of deployable structures, but we can group them into two general categories:

- A) Struts Structures** : scissor-hinged, tensile, and sliding mechanisms, etc.
- B) Surface Structures** : folded, inflatable, telescopic, etc.

The general characteristic of group **A** is that these structures are made out of struts which commonly work as compression, tension or bending components connected by joints or hinges.

In Group **B** stresses are carried by surfaces. In some, cases a continuous surface carries only tension forces like, in pressurized or inflatable construction; other structures are made out of small surfaces or planes joined together by some usually flexible means of forming a continuous structure.

Deployability implies an extra cost over an assembly structure due to more sophisticated, expensive, movable connections, locking mechanisms, and deployment mechanisms . This extra cost has to be balanced by the structure's greater potential for adaptability, mobility, and labor saving construction.

Thesis Supervisor : WACLAW ZALEWSKI

Title: PROFESSOR OF STRUCTURE

TABLE OF CONTENTS

DEPLOYABLE STRUCTURES

Introduction

----- **1**

What Is a Deployable Structure

Existing Applications

**Applications of the Principle of
Deployability to Large Scale Situation.**

Methods of Deployability

DEPLOYABLE STRUCTURES

Components & Requirements

----- **5**

joints

Opening and Closing Mechanisms

Covers

Other Components and Materials

Structural Requirements

Kinetic Requirements

Other Requirements

Form and Resistance

DEPLOYABLE STRUCTURES

Examples

----- **11**

Inflatable Structures

Foldable Structures

Telescopic Structures

Strut Structures

DEPLOYABLE STRUCTURES

Conclusions ----- **17**

DEPLOYABLE STRUCTURES

Design ----- **18**

DEPLOYABLE STRUCTURES

Bibliography ----- **20**

DEPLOYABLE STRUCTURES

Figures ----- **21**



DEPLOYABLE STRUCTURES

INTRODUCTION

This thesis has the purpose of describing the meaning and applications of deployable structures (with emphasis on the scissor-hinged and sliding mechanisms) and the development of new geometries, details, and mechanisms that make these structures buildable and useful for architectural applications.

- WHAT IS A DEPLOYABLE STRUCTURE ?

A deployable structure is one that can be transformed, with the addition of an energy input, from a closed stage or compact configuration to a predetermined, stable expanded form.(Fig.1)

- EXISTING APPLICATIONS

At first glance, deployability might seem to be a very unfamiliar term but examples are more common than one might think. The umbrella (Fig.2) is a typical example of a simple deployable device of every-day use;it is portable, easy and quick to erect, and reusable. These same characteristics will persist in more complex and large deployable devices. We are surrounded by every-day objects that are deployable: foldable furniture, old telephone stands, elevator doors, shop gratings, collapsible boats, automobile tires, water containers, antenna masts, etc,(Fig.3) to mention only some. Activities like camping (Fig.4) are replete with ingenious forms of collapsible shelters, furniture, and accessories. The reason for making collapsible products is clear: mobility. Deployable gadgets can be found in some military applications : masts, parabolic antennas, shelters, bridges.

- APPLICATIONS OF THE PRINCIPLE OF DEPLOYABILITY TO LARGE SCALE SITUATIONS

Deployable structures are suitable in response to the following needs :

a- A situation in which there is a need to create enclosed or protected space for a short period of time and then move that space to another location for erection or storage.

Examples: *-Travelling expositions*

- Fairs
- Provisional shelters
- Movable Hospitals

b- Difficult access places, and/or lack of labor.

Examples: -*Remote retransmissions units*

- Antenna masts*
- Meteorological or research stations*
- Military installations*
- *Emergencies in distant localities, requiring Shelters, Bridges, Hospitals, etc.*

c- Special applications equipment and shelters for special equipment which can not be transported in full open size and needs to be erected in a very quick way.

Examples: - *Portable radars and antennas*

- Portable hangars*
- Portable bridges*
- Protection and camouflage of military equipment*

The US Army has developed two new bridges. One uses foldable aluminum graphite-epoxy honeycomb panels that fold over a trailer for transportation and can be unfolded in few a minutes by means of hydraulic jacks, the second one, using scissor-hinges and triangular frames, is deployed by pulling it with a cable.

d- Need to enclose space due to variable weather conditions.

Examples: - *Stadium covers, Cover-plazas.*

e- Situations of high risk with elevated labor costs, hostile environments, costly transportation.

Examples: -*Earth exploration*

- Space exploration*
- Space stations.*

Space exploration is another field in which deployability has been of immense interest, and many curious devices has been developed under NASA auspices.

f- Construction aid.

Example: - *Reusable scaffolding for complex forms.*

One of the problems of building shell structures is the high cost of the forms needed; this has inhibited the use of these efficient structures. Deployable structures can provide a reusable,

easy to erect scaffolding, for example inflatable forms are now being used for the construction of concrete domes and vault like structures.

g- As a construction method

The traditional view of building has been one of simple accretion. Stone is put on stone, brick on brick, steel on steel, and so forth until the final form takes shape. In modern construction, accretion is often by larger modules in the form of walls, floors, and even entire rooms. A new method consists of bringing the complete structure to the site in some compact configuration and deploying it there for permanent use.

- METHODS OF DEPLOYABILITY

There are many mechanisms which fall into the category of deployable structures, but we can group them into two general categories:

A) Struts Structures : scissor-hinged, tensile, and sliding mechanisms, etc.

B) Surface Structures : folded ,inflatable ,telescopic ,etc.

The general characteristic of group A is that these structures are made out of struts which commonly work as compression, tension or bending components connected by joints or hinges.

This first category includes the scissor-hinged, or lazy tong mechanism, and the sliding, or umbrella mechanism. This work will emphasize these mechanisms.

- THE SCISSOR-HINGED MECHANISM : The basic element of this system is the deformable truss shown in Fig.5 which is a set of struts (one dimensional rectilinear members) connected by nodes (universal joints) , and scissor-hinges (a rotational degree of freedom about the normal plane defined by two connecting struts). This assembly has the characteristic that by rotation of the struts with respect to one another, the assembly encompasses two forms; the first form is the compact state having theoretically one dimension, and the second form is the deployed state, which is a three-dimensional body. (Fig.5)

- SLIDING OR UMBRELLA MECHANISM : This method consists of deploying the structure around a rectilinear support or guide, by sliding a cylindric or hollow joint over it, the more common example is the umbrella (Fig.2).

- HINGED-COLLAPSIBLE-STRUT MECHANISM : This is another method of

deployability which consists of a set of struts hinged at the ends, that allows the structure to be folded. After reaching the final open configuration the hinged joints are locked and the structure behaves as a single continuous piece. (Fig.6)

In Group B stresses are carried by surfaces. In some, cases a continuous surface carries only tension forces like, in pressurized or inflatable construction; other structures are made out of small surfaces or planes joined together by some usually flexible means of forming a continuous structure.

In this category, the more important groups are:

- **INFLATABLE or PNEUMATIC STRUCTURES:** These are structural forms made of a light, collapsible, very strong membrane, stabilized wholly or mainly by pressure differences of gases, liquids, foam, or material in bulk. A familiar example is the balloon, (Fig.7) which is a slack envelope stabilized by gas pressure, enabling it to withstand not only the gas pressure itself, but also to take up other loads. Pneumatic construction is one of the deployable systems most studied in terms of architectural applications and there many examples has been built: greenhouses, shelters, travelling expositions, water tanks, covers, bridges, dams, etc.

- **FOLDED STRUCTURES :** Another type of deployable structure can be collapsed and expanded like an accordion; it can be of two types. One made of rigid panels joined by a flexible connection along its edges, and the other is made of a continuous flexible material which allows itself to be folded.(Fig.8)

- **TELESCOPIC STRUCTURES :** These structures are based on tubular elements that can enter one inside the other, forming a compact packet which is then telescoped and stabilized to its final configuration. This concept is used a lot in mechanical devices, such as cranes, masts, and antennas, but its application in architecture has not been explored much. (Fig.9)

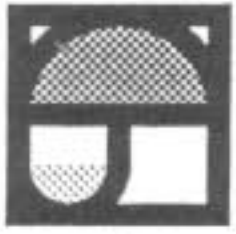

DEPLOYABLE STRUCTURES COMPONENTS & REQUIREMENTS

- JOINTS

The successful behavior, duration, and reliability of a deployable structure will depend on a great way in its joints. The joints are points at which forces converge, and their ability to resist and transmit those forces will determine to an important degree the soundness of the structure the joint should meet the following criteria :

1. Should transmit the forces evenly throughout the components which arrive at that point.
2. It should firmly hold all the struts which meet at that point.
3. It should give every strut enough freedom to go from the closed stage to the open one, but avoid holding the struts too loosely.
4. In the cases where reusability is required, the joint has to be designed to stand the stresses created during the erection process, minimizing fatigue in the material.
5. Friction between the moving pieces should be minimized to avoid excessive wearing and to facilitate the erection and dismantling processes.
6. As we are dealing with moving connections (usually pin connections), it is important to take into account, when designing and choosing the material, that the transference of forces between bodies which are not bonded together can occur only by the pressure exerted by one body against another; the values of compressive or tensile stresses increase at the joint. The flow of compressive forces are curving in the vicinity of the joint resulting in the need for an internal pulling action towards the center of the element; such an action always causes traversal tension to develop within the material. As a result, the element may crack and split longitudinally, if measurements are not taken. Thus, it is very important to have tension resisting materials around the connection.

- OPENING AND CLOSING MECHANISMS

Another fundamental aspect to consider when designing a deployable structure is the open-closing mechanism. As size and weight increase opening and closing a deployable structure become a more and more problematic factor in the effective good functioning of the concept. The structures have to be provided with a mechanism to accomplish the

erection-dismantling process, these mechanisms can go from manually driven ones to fully automatic and even remote-controlled ones. But every system will depend on each structure, and in particular, on its size and weight, frequency and conditions of deployment, environmental factors, possibility of energy sources, etc.

Opening and closing mechanisms can be hydraulic systems, motor or manually-driven screws, cables and pulley mechanisms, spring-driven mechanisms, etc. But any mechanism use should provided a even movement of all the parts at a controlled rate. Since the structures usually start the deployment process running horizontally over the erecting surface, for those structures to be erected over surfaces or terrains it is convenient to mount them over wheels in order to reduce friction with the surface, thus reducing the force needed for the erection.

- COVERS

There are some situations which require a protected or enclosed space, and the deployable structure has to be designed with an enclosure or cover system. There are many different solutions:

The enclosure system can be attached to the structure or free-standing; the enclosure can be added after the structure is erected, or it can be permanent part of the structure. It can also operate as a structural member, stabilizing member and/or locking member of the open configuration. Enclosures can be made out of light and flexible materials, which can act as tension carries, Such as teflon coated nylon or fiberglass fabrics, etc. Or they can be made out of rigid materials like metals or plastics.

- OTHER COMPONENTS AND MATERIALS

The structure should be made out of materials which are light (for easier transportation) but at the same time strong enough to stand the stresses and deformations to which the structure is subjected ; in some cases flexibility is a desirable property. Materials like aluminum, laminated steel, steel, plastics, or composite materials like fiber-glass epoxy or graphite-epoxy are commonly used.

For the compression or bending members of the structure, tubular struts are a reasonable solution, due to their weight/resistance relationship and good resistance to bending; for tension components, high resistance steel cables or fabric are used.

- STRUCTURAL REQUIREMENTS:

Clearly an essential structural requirement for all the forms with which we shall be concerned is that they shall stand and not collapse. They should carry their own weight and the live loads to which they will be subjected (wind, snow, other components attached to the structure, etc.), and under normal circumstances they should have adequate margins and stiffness in all structural elements and in their interconnections.

The basic element of the scissor-hinged mechanism, as we saw before, is the deformable truss shown in Fig.5. Due to its one degree of freedom this truss is unstable, and has no structural properties. Although if height "h" is fixed, the truss will be able to carry loads acting on its plan. As it is not triangulated, its struts are working in flexion (Fig.10). By adding compression and tension members to the system, bending stresses can be reduced and the truss will become a triangulated one, where stresses are mainly transmitted by tension or compression. By using more suitable geometrical forms, and by locking the joints, the structural characteristic of the system can be improved.(see examples R to V)

- KINETIC REQUIREMENTS :

Returning to our basic truss (Fig.11). If height "h" is modified by any mechanical means, the "l" dimension will change with any variation of "h" according with the number of crosses and the length of the struts. When "h" is equal to $b+a$ the system is in its close configuration, and when "h" approaches 0 height, the system will theoretically approach a straight line and "l" will be maxima.

For the system to obtain its closed configuration the only relation that has to be kept is, that around any pair of nodes A, B, ($a' + b' = a'' + b''$). Keeping that relationship, new combinations, with our basic system, are possible; Fig.12 shows an example.

Until now we have only dealt with planar elements, but tridimensional combinations are possible too, and the system will be closed if the same relationship used for the planar configuration is kept. By crossing two planar elements perpendicular, a tridimensional group of families is created (Fig.13); by intersecting three planes we obtain another tridimensional configuration (Fig.14), in which the basic element is a triscissor. It is a mobile assembly, of six struts, six nodes, and three scissor hinges, in which all the struts lie in one plane for a given value of the angle β (Fig.15). The required action of a triscissor is such that, as β increases the assembly folds rigidly out of the plane, passing through a three dimensional form and reaching a limiting one dimensional state for $\beta = 180$ degrees. This action places constraints on the relative values of a, b, c, d. It is a necessary and sufficient condition for the mobility of a

triscissor that the six struts in the plane are tangent to a circle. The triscissor is an important basic unit for some tridimensional forms like domes.

Until now we have dealt only with flat structures in which $a=a'$ and $b=b'$ but what happens if the center of rotation is moved out of the center ?. By making $a' > a$ and $b' < b$, the basic truss starts to bend (Fig.16). The bigger the difference between a' , a and b' , b the smaller the radius of the curve. The radius of the curve and the number of crosses will define the length of $a+a'$ and $b+b'$.

According to the desired curve and the number of divisions, the length of the struts and the position of the scissor-hinge can be calculated (Fig.17). Let us choose an arch of radius R and divide it in six equal parts; the length $L = a+a'$ is equal to $R * \tan \varnothing = L$, where $\varnothing = 180$ (half circumference)/ 6 (# of parts) = 30, and $a = R \tan \varnothing/2$, $a = L - a'$, and because each scissor is symmetrical $a' = b$, $b' = a$.

With the scissor-hinged deployable system it is possible to make flat structures, and structures with a single or double curvature, positive or negative, following the method described above. By repeating an arch, a simple vault structure will be obtained-by rotating it, a dome, etc. The same type of geometrical forms can be obtained, by using as a basic unit the triscissor described before.

- OTHER REQUIREMENTS

It is not only important to have a structural soundness, and the correct geometrical relationship between the parts, which allow the structure to be transformed and to acquire the desired shape, but it also has to be reliable and buildable. A deployable structure has any advantage, if it can not be opened, closed, or reused. As it was mentioned before joints are a crucial point, but the right dimensioning and positioning of all parts are as important. In many of the models we have built problems during the transformation process were generally due to small mistakes in the dimension of some parts. To avoid mistakes in the dimension and position of parts, the variety of these should be as small as possible, at the same time this will facilitate the production of parts, the assembly, and reduce the cost of the structure.

- FORM AND RESISTANCE

The load capacity of a structure can be increased without increasing the amount of material, by choosing an adequate form. This is of special importance when designing deployable structures, because increasing the carried-capacity by adding material will make the movable joints used more expensive than they already are, and will increase the weight of all

components, therefore the overall weight of the structure, reducing its efficiency and transportability.

Forms which allow the stress to be transferred mainly by compression or by tension are more efficient. The catenary and the arch are examples of those forms. When a cable is loaded by a single load, it will adopt a configuration in which the two sides are straight and the weight is transmitted by tension to the supports. If another load is placed on the cable in another location, the cable adapts itself and carries the load by acquiring a new configuration with three straight sides. If the number of loads is increased, the cable acquires new equilibrium configurations with straight sides between the loads, and changes in direction at the points of application of the loads. The shape acquired by the cable is called funicular polygon.

As the number of loads in the cable increases, the funicular polygon acquires an increasing number of smaller sides, and approaches a smooth curve. If one could apply to the cable an infinite number of infinitesimally small loads, the polygon would become a funicular curve. If the loads are distributed evenly along the length of the cable, the configuration will be a catenary, if they are evenly distributed horizontally, the configuration will be a parabola. If the shape assumed by the cable when it is uniformly loaded is turned up, the ideal shape of an arch, developing only compression, will be obtained. The ideal shape of an arch capable of supporting given loads by means of simple compression may always be found as the shape of the overturned corresponding funicular polygon.

There are other forms which have the same properties of the linear funicular systems, cables and arches. They can be classified as forms with single curvature, (cylindrical or conical) or forms with double curvatures (spheres, ellipsoid, hyperbolic paraboloid, etc.).

The dome is an example of those three-dimensional forms in which, ideally, there is no bending (and therefore no variation in stress through the thickness at any point), and in which internal forces are represented by sets of principal tensions and compressions. One set of principal stresses acts radially from the crown to the base. These stresses are compressive throughout and may be likened directly to the thrusts in a large number of arches into which the shell might be split by cuts on vertical radial planes. The other set of principal stresses in the shell acts horizontally and circumferentially to prevent the upper part of the shell from falling toward the center and the lower parts from bursting outward. These stresses are compressive near the crown but become tensile nearer the base.

By a translation movement of an arch, a vault will be obtained. It works similarly to an arch, when loads acting on each transverse strip are the same. If the transverse shape of the vault is the funicular for a certain load, each strip will develop only compressive stresses in the direction of curvature and no longitudinal stresses between adjacent carried strips. If the cross section is not the funicular of the loads, bending stresses may develop in the arched strips.

Other shell forms behave in a more complicated way, but in all of them the stresses are mainly tensions and compressions.

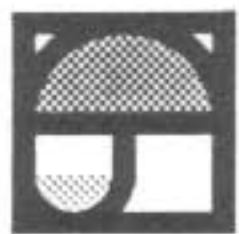

DEPLOYABLE STRUCTURES

EXAMPLES OF DEPLOYABLE STRUCTURES

In this section some examples of deployable structures will be showed and described.

- INFLATABLE STRUCTURES:

Example A Fig.18 shows an air-inflated travelling exhibition pavilion designed by Joseph Eldredge for the United States Atomic Energy Commission and fabricated by Birdair. It resembles a huge inflated pillow that is supported by slender columns.

Example B Fig.19 shows a section through an air-supported office, manufactured from translucent p.v.c.-coated nylon. This was one of the first applications of inflatable structures to office space. It was built as a provisional solution to a shortage of office space, in the growing electronic industry, while a more conventional building was built.

Example C Fig.20 Shows the STEM lunar shelter developed by the Goodyear Aerospace Corporation as a emergency shelter for the Apollo mission. It is fabricated from flexible material reinforced by high strength stainless steel filaments. The shelter has a fully conditioned and self supporting environment.

Example D Fig.21 shows an air-inflated structure erected in the snows of Norway. It is a 16m long by 9m wide, with dual-walled construction, made out of four pieces joined together by zip fasteners, designed to withstand winds of up to 150 kph and very low temperatures. It is an example of the application of this structure to remote and hostile environments.

- FOLDABLE STRUCTURES:

Various economical shelters have been designed using the concept of foldability.

Example E Sim Van Der Ryn and Sanford Hirshen proposed a foldable housing solution for California migratory workers (Fig.22), made out of a prefolded structural shell of 3/8" polyurethane foamboard.

Example F Fig.23 shows a folded plate conical dome shelter designed by B. S. Benjamin (professor of architecture at the University of Kansas).The panels are made of a rigid polyurethane foam core sandwiched between resin impregnated Kraft paper and joined to each other with tape as a flexible joint. The entire structure can be folded and packaged into a single kit of 2.2m by 1.6m by .38m with a approximate weight of 63.5 kg.

Example G Fig.24 shows a proposition for a movable roof for twin stadiums in Kansas city, Missouri.

Example H Fig.25 shows a student project at the University of Virginia of a deformable auditorium. The entire unit, including walls, roof and bleachers, is self-articulating for both erection and compaction.

Example I Fig.26 shows a military portable shelter developed for NASA. It is made of .4" thick sandwich panels and a neoprene-coated nylon used as flexible joints. The entire structure for a 488 ft² shelter can be packaged into a box 8'10"long by 4'4" wide by 3'4' high. The entire shelter weighs 650 pounds.

Example J Fig.27 shows two concepts developed by International Structures Inc. They are small 17' by 24', and 16' by 32' accordion type structures made of polyurethane foam boards and reinforced with aluminum tape.

- TELESCOPIC STRUCTURES:

Example K Fig.9 shows a proposal for a mobile home made by John Vredevoogd. It is based upon a series of eight-foot sections. The sections are transported on a truck. When in position the units are telescoped and stabilized. After the truck is removed all eight units are lowered. The sections then can be offset from one another along transverse girders, creating a staggered plan.

- STRUT STRUCTURES:

Example L Fig.28 shows a deployable dome, (first patented by Zeigler), which has as a basic unit a set of struts joined together by universal joints and scissor-hinges. The whole system can be collapsed to a small packet whose length is in the order of one tenth the diameter of the

dome. This dome is a self-supporting structure; it cannot take loads other than its own weight. The stability of the open configuration is due to bending in the members. Fig.28 shows details of the connections.

Example M is a system developed and marketed by Astro Research Corporation, for deployable trusses (Fig.30). The system consists of a rigid square frame comprised of members (76). The frame is rotated thereby raising members (77) from the parallel transport position while pivoting at connection (75 and 78). The cube formed is stabilized by stretching one of the diagonal tension members, and the process is repeated until the completed structure is fully deployed.

Example N Fig.31 and Fig.32 show another system for a collapsible frame structure. Made of light weight flexible interconnected strips, which can be rapidly expanded to define a rigid hollow dome-like structure this system was developed by Schulze & Bye at the State University of Iowa. As an opening and locking mechanism, the structure uses a sliding umbrella like mechanism.

Example O Fig.33 shows a deployable structure in which the scissor-hinged mechanism is combined with the sliding one. Four outer column serve as a guide for four sliding joints which hold the hinged struts. The central guide is the closing, opening, and locking mechanism (Fig.34). By initially pulling apart the four external guides, which have retractile wheels to reduce friction,(Fig.35) and then turning the threaded central guide until the lower and upper central joints meet, the structure will be fully open and stable.

Example P Fig.37 shows a deployable dome which consists of six scissor-hinged arms, deployed by bringing together the upper and lower central joints. This is achieved by a motor driven mechanism (Fig.36) which is placed over the center of the dome and has a threaded bar between the upper joint and the motor. The structure is stabilized by closing a circular cable at the base of the dome. The cover, not shown, is a permanent part of the structure and contributes with the lateral stability of the arches which conform to the dome.(Transverse tension members are not shown.)

Example Q Fig.38 shows a deployable modular structure which is deployed, with the help of a pulley-cable mechanism, by sliding the lower joint over the column used as support. Placing these modules one in front the other, at one side or in a radial manner, different configurations and sizes of enclosures can be obtained.

dome. This dome is a self-supporting structure; it cannot take loads other than its own weight. The stability of the open configuration is due to bending in the members. Fig.28 shows details of the connections.

Example M is a system developed and marketed by Astro Research Corporation, for deployable trusses (Fig.30). The system consists of a rigid square frame comprised of members (76). The frame is rotated thereby raising members (77) from the parallel transport position while pivoting at connection (75 and 78). The cube formed is stabilized by stretching one of the diagonal tension members, and the process is repeated until the completed structure is fully deployed.

Example N Fig.31 and Fig.32 show another system for a collapsible frame structure. Made of light weight flexible interconnected strips, which can be rapidly expanded to define a rigid hollow dome-like structure this system was developed by Schulze & Bye at the State University of Iowa. As an opening and locking mechanism, the structure uses a sliding umbrella like mechanism.

Example O Fig.33 shows a deployable structure in which the scissor-hinged mechanism is combined with the sliding one. Four outer column serve as a guide for four sliding joints which hold the hinged struts. The central guide is the closing, opening, and locking mechanism (Fig.34). By initially pulling apart the four external guides, which have retractile wheels to reduce friction,(Fig.35) and then turning the threaded central guide until the lower and upper central joints meet, the structure will be fully open and stable.

Example P Fig.37 shows a deployable dome which consists of six scissor-hinged arms, deployed by bringing together the upper and lower central joints. This is achieved by a motor driven mechanism (Fig.36) which is placed over the center of the dome and has a threaded bar between the upper joint and the motor. The structure is stabilized by closing a circular cable at the base of the dome. The cover, not shown, is a permanent part of the structure and contributes with the lateral stability of the arches which conform to the dome.(Transverse tension members are not shown.)

Example Q Fig.38 shows a deployable modular structure which is deployed, with the help of a pulley-cable mechanism, by sliding the lower joint over the column used as support. Placing these modules one in front the other, at one side or in a radial manner, different configurations and sizes of enclosures can be obtained.

Example R Fig.40 shows a vault-like, self-supporting deployable structure made of aluminum machine joints (Fig.39) and aluminum struts. The structure is stabilized when the flexed members pass over a critical point. The structural capacity of this structure is improved by building it from arches of different radius in an alternated way ,so to obtain a folded plate like structure.

Example S Fig.41 shows a detail of a joint. In this model the out of plane position of the struts (plane created by the four nodes and the scissor-hinge),creates a flexion in the members. To avoid this flexion an alternated configuration of one and two strut was used instead of a single strut. Fig.42 shows opening-closing mechanism which allows, with a small distance travelled and therefore a smaller threaded bar, which is very convenient in large structures, fully open the structure. A bar, which can be seen between the lower and upper joint, is the stabilizing and locking mechanism. Once the lower end of the bar is fixed, the structure is not only frozen but its load-carried capacity is improved.

Example T Fig.43 shows another way to improved the load-carried capacity of a deployable vault-like structure. By adding an extra member in the lower part of the original truss, a continuous arch is created. This will help to reduced the stresses on the movable connections, and release the members from part of the bending, that is produced in untriangulated trusses.(Fig.10)

Example U Fig.44 In this case an additional member is added on the upper part of the truss with the same result than in the previous case, but in a more simpler and clear way.

Example V By prolonging the lower extremes of the struts the same result that in example S can be obtained, but in this case as an integral part of the basic truss system (Fig.45). Once the expanded configuration is achieved, the ends can be fixed by pins, and a rigid-trussed arch is obtained. Fig.46 and Fig.47 show two similar vault-like structures built using this principle. One of them has incorporated an opening-closing mechanism, which used two threaded bar placed symmetrically on the structure. The number of rigid interconnecting elements between arches were reduced, (Fig.48) and the triangulation is achieved by diagonal tension members, not shown in the photographs. The cover is hanged below the structure, once its stabilized, by mean of two parallel and continuous channels made in the lower part of the arches.

Example W Fig.49 shows a different mechanism that the ones we have see until now. It is made from small plane metallic strips, which pivoted about and folded on one another, and

rigid frames. The structure is deployed by pulling from one of the ends, and it is stabilized by stretching the entire frame and fixing it to the ground.

Example Y Fig.50 shows a small deployable tent that can be combined to create exhibition spaces, or can be used as information or temporary selling kiosks. It has an aluminum structure which becomes rigid due to the tension generated by the stretching of the fabric.

Example X Fig.51 through Fig.56 show a project for a temporary exhibition space done by students of the building technology group fall 85 at MIT. The space was designed for easy erection and demounting, in a period of about three weeks. The structure is composed of equilateral-triangular-deployable space-frames, joined together and supported, by aluminum columns placed at the vertex of the triangles. The space frames are constituted by extruded aluminum bars with oval section, and casted joints (Fig.52 and Fig.53). The space-frame is deployed manually and lifted up to place by a pulley mechanism (Fig.54), stabilized and locked by the floor element which serves as an upper compression member at the same time (Fig. 55), the load-bearing capacity of the space frame is increased with post-tensioned cables running from each column to the center of each triangular unit. The skin is made from a teflon-coated nylon fabric, anchored to the aluminum structure.(Fig.56)

Example Z Space Station Fig.57 This project was realized at MIT during the fall of 1985 as an student run workshop. NASA requirements and constraints for the 1990 space station were used. Structural requirements: a structural mainframe system to support the modules, the living-support systems, communications, etc., of the space station were required. This mainframe should be able to be transported by the space shuttle, which has a limited capacity of 29,484 kg and 18m long by 4.5m in diameter, in the least possible number of flights and erected in orbit using the fewest possible man-hours. This is due to its high cost in terms of money and risk of having a man working in the space.

A deployable structure was chosen, with a spring loaded opening mechanism designed for one way operation. The space station construction operations begin with the deployment of the platform, which is based upon a 5m by 5m by 5m cubic module. The 35m by 25m platform in its transport configuration (Fig.58) is secured in the shuttle bay utilizing restraining supports at each of its ends (25).

The platform spring loaded deploying operation consists of one continuous deployment in three directions whose rate is regulated by a circumferential banding system (27). Each module in the platform consists of 5m rigid struts (23) and a 5m collapsible struts (24) hinged at (21) that pivot in relationship to (23) at connection point (20). Corner bracing between (24) and (23) is

achieved with strut (22). Upon strut (24)'s complete assumption of the horizontal, the spring (29) loaded Collar (30) mechanism (Fig.59) at (21) moves into position securing the bi-pivotal linkage assembly shown in Fig.60. The hub assembly at (20) consists of an aluminum housing assembly (32) Fig.61, Fig.62 and four pivotal points (31) for the connection of four struts (24). The knob assembly (20) is used as universal attachment point for various components. A circular deployable truss is also use in the space station as a track for a mobil manipulator arm Fig.63. This structure use the scissor-hinged mechanism and is deployed hydraulically. The stability of the final configuration is achieved by locking the collapsible track.(see details Fig.64)

Another deployable system incorporated in this design is a deployable hangar for satellites service in which by a scissor-hinge arms a protective enclosure is hydraulically deployed.(Fig.65).



DEPLOYABLE STRUCTURES CONCLUSIONS

Deployable structures are competitive with other erecting systems in situations where: speed of erection is essential, field labor costs are very high or labor is not available, field erection and reerection are required, and transport of large volumes is not possible.

Deployability implies an extra cost over an assembly structure due to more sophisticated, expensive, movable connections, locking mechanisms, and deployment mechanisms. This extra cost has to be balanced by the structure's greater potential for adaptability, mobility, and labor saving construction.

Deployable structures need less, and less specialized, labor for their erection; the complete erection or dismantling is realized in a fraction of the time needed for assembly structures, so deployable structures become competitive in situations in which there is a need for a repetitive erection-dismantling process.

There are other circumstances in which the difficulty of transportation, the hostility of the environment, etc. make deployability the only alternative. The reliability and therefore the successful behavior of a deployable structure depend on a design which takes into consideration the environment or conditions where the structure will be used and reused, and ^{use} one parts and materials suitable to the specific situation.



DEPLOYABLE STRUCTURES DESIGN

The plaza Simon Bolivar of the Universidad Central de Venezuela (Fig.66) is a very convenient place, due to its location, availability of parking place, public transportation, and its relation with the university, for exhibition, fairs, and many other activities which require a large space. The plaza had already been used successfully for some of those activities. This project is part of a proposal which aims at the improvement of that area, and increase of the university's profits from it.

Requirement : A structure that can provide a temporarily covered area, under which a number of different activities can occur. This structure should be easy and quick to erect and dismount, and easy to transport and store.

For solving the problem a group of umbrella-like structures were chosen. These umbrellas will be permanently placed on the plaza, and only the covers will be taken away when the umbrellas are not used. The remaining part of the structures will be in a closed configuration, and in some cases, the supports will be used as illumination posts, or will hold sound equipment. The supports should be aesthetically integrated with the plaza, not affecting its character. The fabric, used as a cover element, will be removed to avoid deterioration, which can be caused by dirt and humidity held between its folds.

- DESCRIPTION OF THE STRUCTURE

Fig. 67 shows an elevation of the structure. A central support, made of aluminum and permanently fixed to the floor, holds six arms which are elevated by a set of cables. The cables are driven by a winch. The cover (high-resistance-light fabric) is attached to the end of each arm and to the rim that can be seen in cross section E. As the arms are erected, the fabric is simultaneously tensioned, bringing this way the whole structure to stability. When the structure is not in use the fabric is removed, and the arms remain in a vertical position parallel to the support and held in place by a belt.

Fig 68 shows a plan of the structure, in both close and open configuration. The open umbrella has a radius of 6.2 mts, the height to the lower part of the cover is 4.0 mts, and the total height is 8.0

mts. The arms are made out of hollow aluminum pipe which is able to resist compression and bending stresses. The opening and closing mechanism cables function as upper tension members, while the fabric works as a lower tension member.

Fig. 69 shows a cross section through the set of pulleys which support the cable mechanism. The six cables go to a central joint, where from, only one cable continues to reach the winch.

Fig. 70 shows a top view of the joint which hold the six arms of the umbrella. It was designed to be assembled out of aluminum pieces without the need to weld or using of cast pieces.

Fig. 71 shows the rim which hold the lower part of the fabric and allows the fabric tensioning.

Fig. 73 shows a cross section through the support in which the different elements of the structure can be seen. There is an electric conduit which run along the support to provide energy to the lamps or sound equipment that can be placed on top of the structure.

Fig. 74 shows detail of the arms. The connection of the control cables to the arm, and the connection of the arms to the fabric. The element placed perpendicular to the arm, at the end, close to the support, allows the increase of the angle between the cables and the support, when the arms are in the closed configuration. It reduces the force need to start erection of the arms.

Fig. 75 shows the assembly sequence of one umbrella. The configuration is closed (1); the arms are slightly opened (2); the fabric is attached to the structure (the attachment points in the arms are easy to reach at ground level, while to reach the attaching point at the central support a ladder is needed). (3); the arms are erected until the fabric is stretched (4.).

Figs. 76 and 77 show one of the possible combinations of the umbrellas, to create a covered space.

Fig. 78 to 80 show photographs of the structure model.



DEPLOYABLE STRUCTURES BIBLIOGRAPHY

- 1- Roger N. Dent " *Principles of pneumatic architecture*" The architectural press, London 1971.
- 2- William Zuk " *Kinetic Architecture*" Van Nostrand Reinhold Company, New York 1970.
- 3- Rowland Mainstone " *Developments in Structural Form*" The MIT press, Cambridge, Mass. 1983.
- 4- B. S. Benjamin " *Architectural and Structural evolution of Dome Shelters*"
- 5- AFAPL TR 68-17, Transactions " *Third Aerospace Expandable and Modular Structures conference*" Sponsored by : Air Force Aero propulsion laboratory (Space Technology Branch) Wright Paterson Air Force Base, Dayton Ohio. Florida May 16-18, 1967.
- 6- United States Patent 4,026,313. Zeigler may 31, 1977.
- 7- United States Patent 3,000,386. J. H. Schulze et al sept. 19, 1961.
- 8- International Patent WO84/01094. Nodskov sept. 24, 1983.
- 9- United States Patent 3,486,279. j. Webb dec. 30. 1969.
- 10- Building Systems Design Group " *Design and Development of a Building System for and Exhibition Space*" Report MIT, fall 1985.
- 11- Building System Design Group " *Space Station Workshop*" Report MIT, fall 1986.
- 12- Mario Salvadori " *Structure In Architecture*" Prentice-hall international, inc. New Jersey, 1963.
- 13- Ludwig Glaeser " *The Work of Frei Otto*" The Museum of Modern art, New York, 1972.
- 14- Frei Otto " *Naturliche Konstruktionen* " Deutsche Verlags-anstalt, Stuttgart, 1982.
- 15- United States Patent 3,325,958. A. B. Moore, June 20, 1967.
- 16- John M. Hedgepeth & Louis R. Adams " *Design Concepts for large Reflector Antenna Structures*" NASA contractor report 3663, 1983.
- 17- Technical support package " *Deployable Geodesic Truss*" NASA lar-13113 Langley Research Center.
- 18- Frei Otto " *Tensile Structure* " MIT press, Cambridge, Mass. 1979.
- 19- Marks " *Dymaxion World of Buckminster Fuller*" Reinhold Publishers, New York, 1960.
- 20- R. B. Fuller " *Inventions* " St. Martin's press, New York, 1983.
- 21- Felix Escrig " *Estructuras Espaciales de Barra Desplegables* " Informes de la Construcción, Vol 36, #365, noviembre 1984.
- 22- United States Patent 3501876 ,W. H. Engle , "Modular Structure" March 24, 1970.

- 23- United States Patent 3362118 A. Brunner, " Expansible Surface Structure" Jan. 9, 1968.
- 24- Technical support package " *Explosive Welding For Remote Applications* " NASA lar-13119 Langley Research Center.
- 25- Technical support package " *Synchronously Deployable Truss* " NASA lar-13117 Langley Research Center.
- 26- NASA Tech Brief "*Synchronously Deployable Truss* " summer 1984/ B84-10350/ NASA lar-13117 Langley Research Center.
- 27- NASA Tech Brief " *Synchronously Deployable Truss* " July/August 1986, NASA lar-13490 Langley Research Center.
- 28- Mc Donald Schetky, " *Shape-Memory Alloys* " Scientific America, Vol 24, #5 , pp. 74-84. November 1979.
- 29- M. L. Clevett " *Portable Bridge Design comes down to earth* " ENR pp. 34, August 22, 1985.
- 30- Astro Research Corporation " *Information Cataloge* " 1979.
- 31- Dornier Systems "*Extendable and Retractable Mast* " information cataloge.
- 32- Felix Escrig." *Expandable Space Frame Structures* " Third International Conference of Space Structures, Elsevier Applied Science Publishers, New York, 1984. pp. 845-850
- 33- Oscar Sircovich Saar "*Self-Erecting Two Layer Steel Prefabricated Arch* " Third International Conference of Space Structures, Elsevier Applied Science Publishers, New York, 1984. pp. 823-827.
- 34- R. C. Clarke " *The Kinematic of a Novel Deployable Space Structure System* " Third International Conference of Space Structures, Elsevier Applied Science Publishers, New York, 1984.pp.820-822.
- 35- J. F. Gabriel " *A Space-Frame Building System For Housing* " Third International Conference of Space Structures, Elsevier Applied Science Publishers, New York, 1984.pp. 1052-1057.
- 36- Hugo F. Verheyen "*Expandable Polyhedral Structures Based on Dipolygonios* " Third International Conference of Space Structures, Elsevier Applied Science Publishers, New York, 1984. pp.88-93.
- 37- Mark A. Bresh " *Combining Space Frame and Fabric Structures* " Third International Conference of Space Structures, Elsevier Applied Science Publishers, New York, 1984. pp. 851-854.
- 38- R. B. Haber, LLOYD Tuner, Others." *Air-Supported Forming*" Concrete International, pp.13-69. January 19

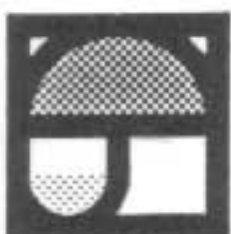

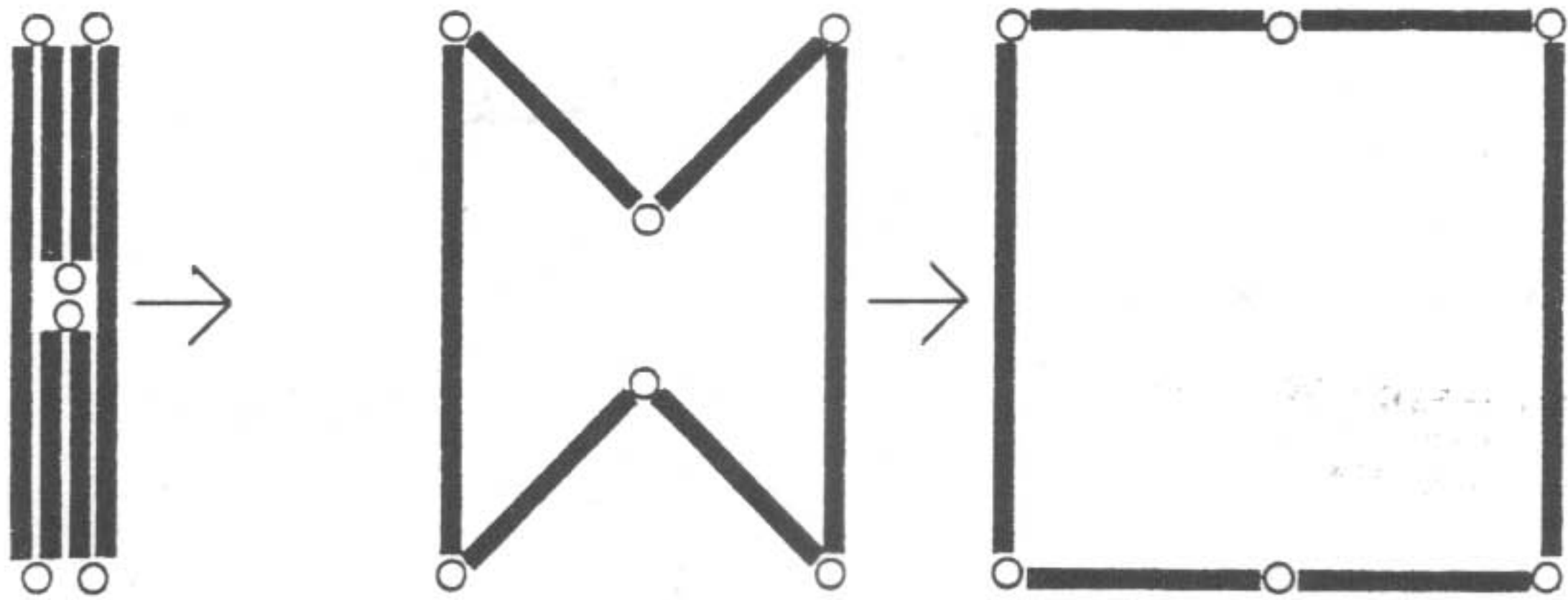

Figure 1



Figure 2

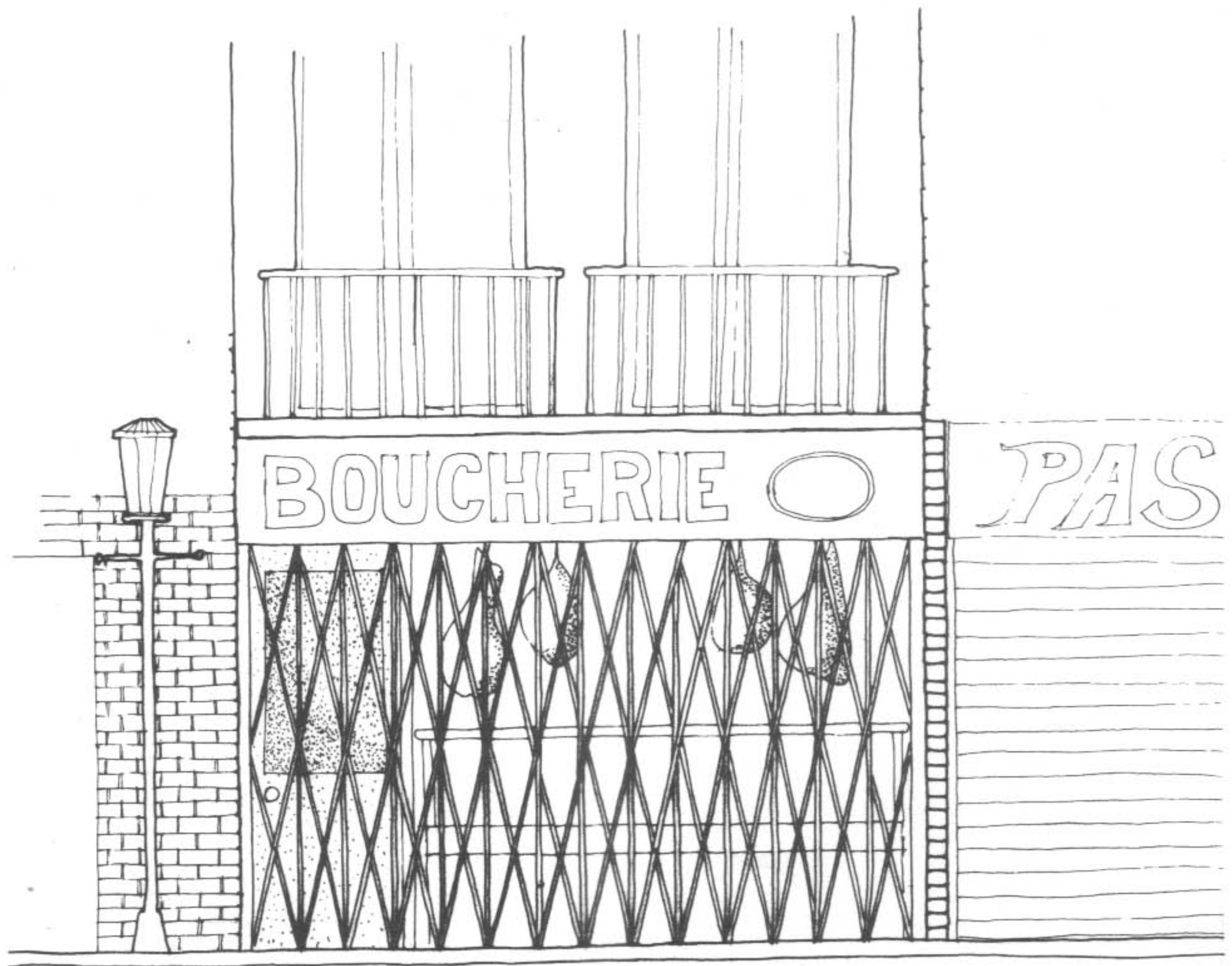

Figure 3



Figure 4

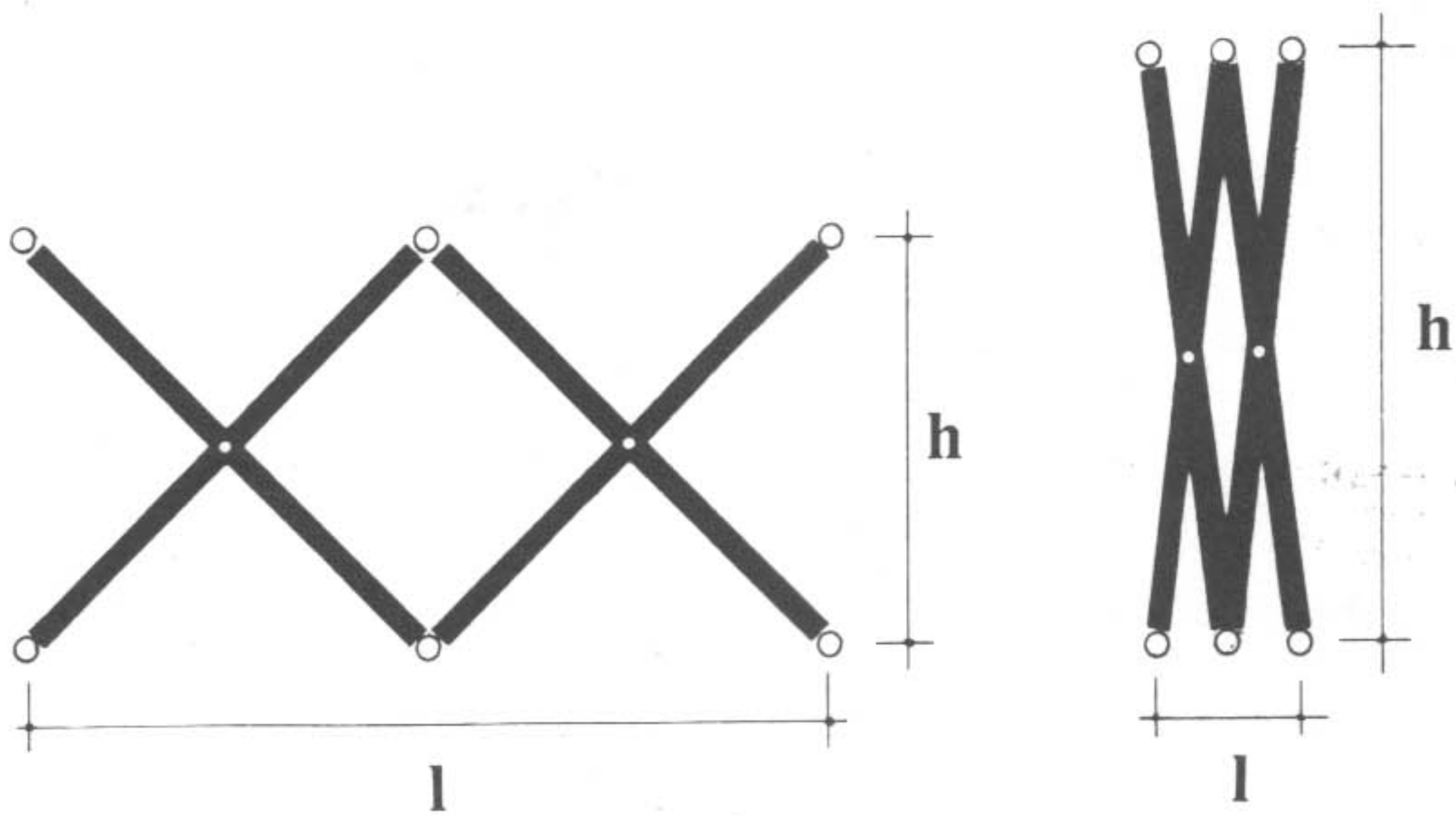

Figure 5

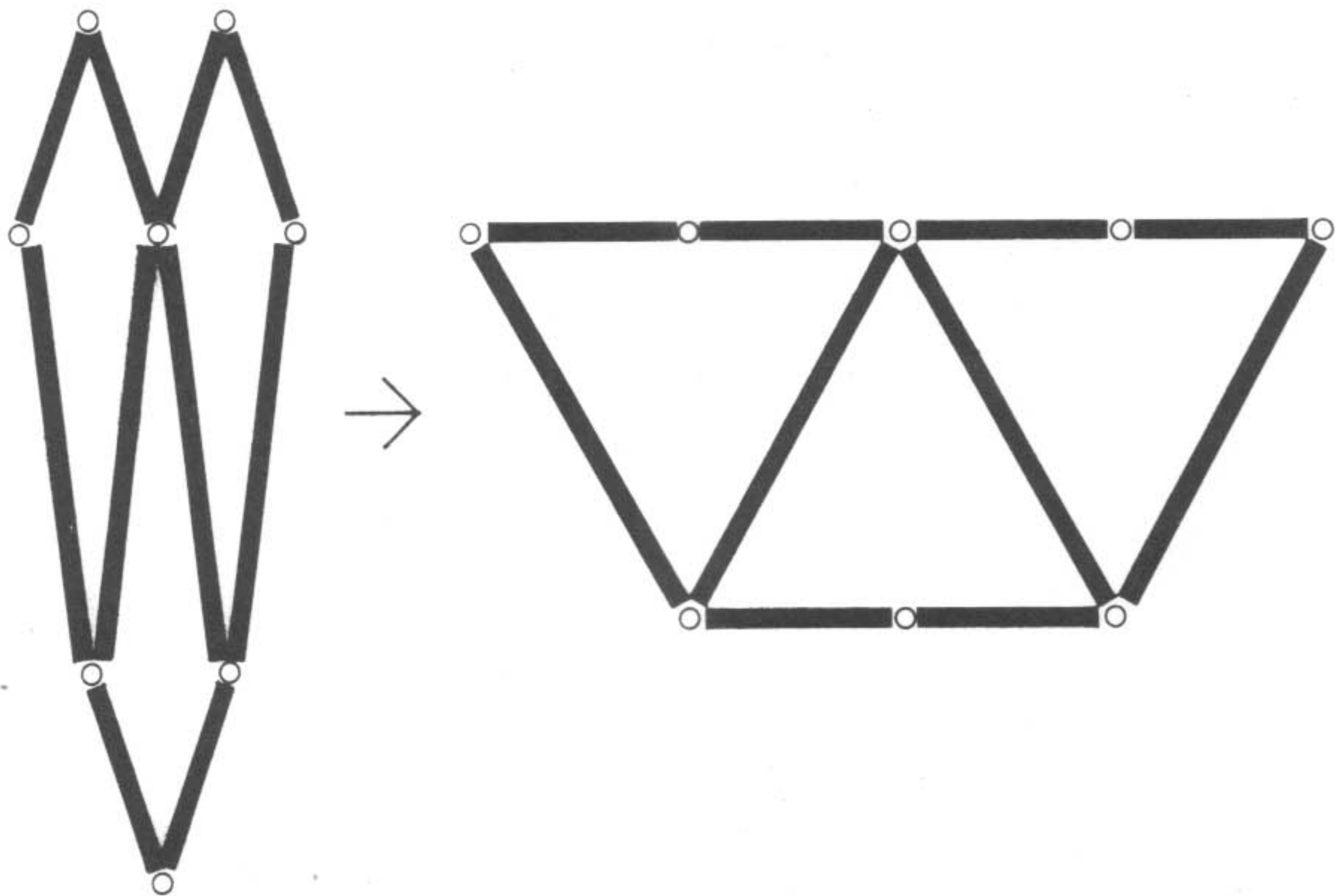

Figure 6



Figure 7

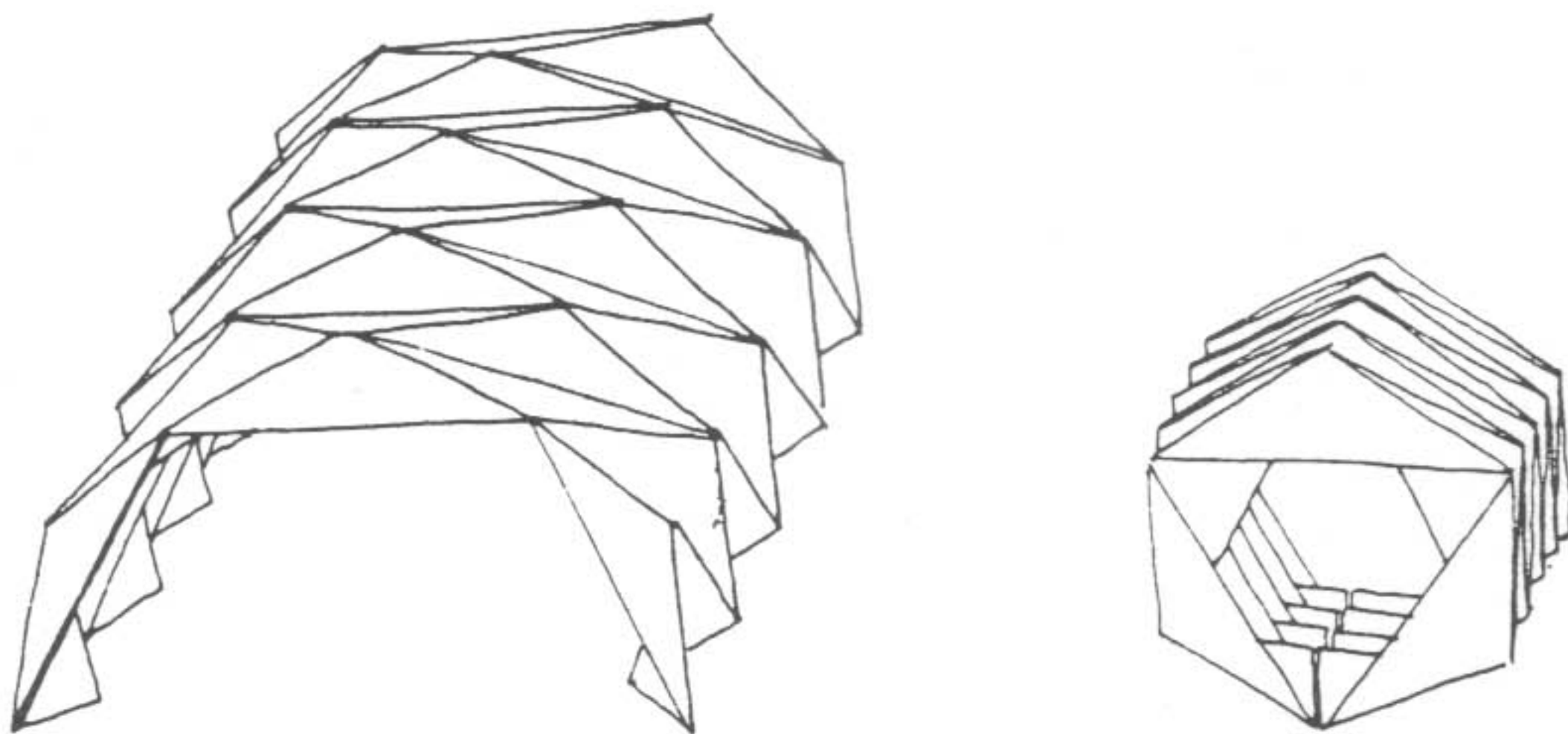

Figure 8

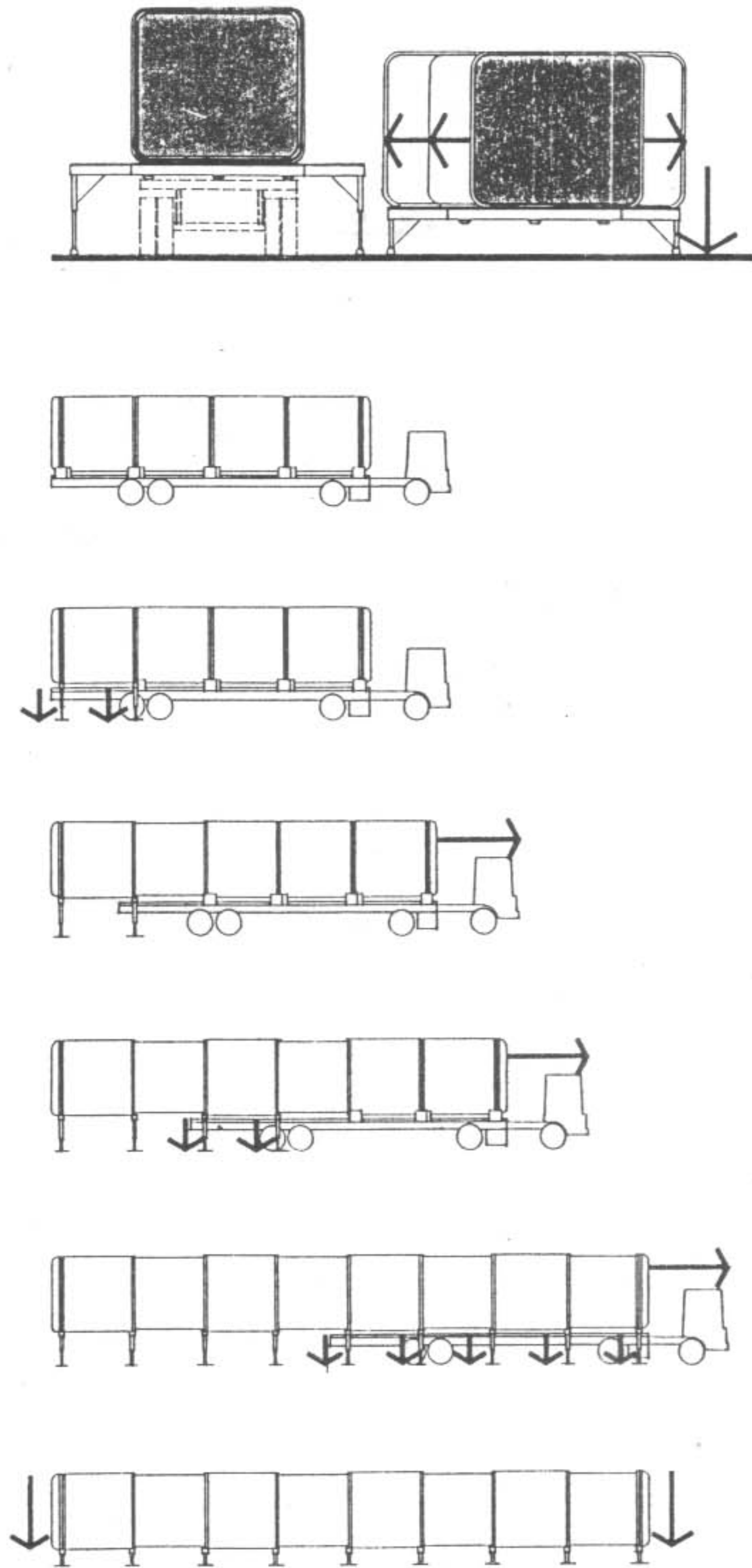

Figure 9

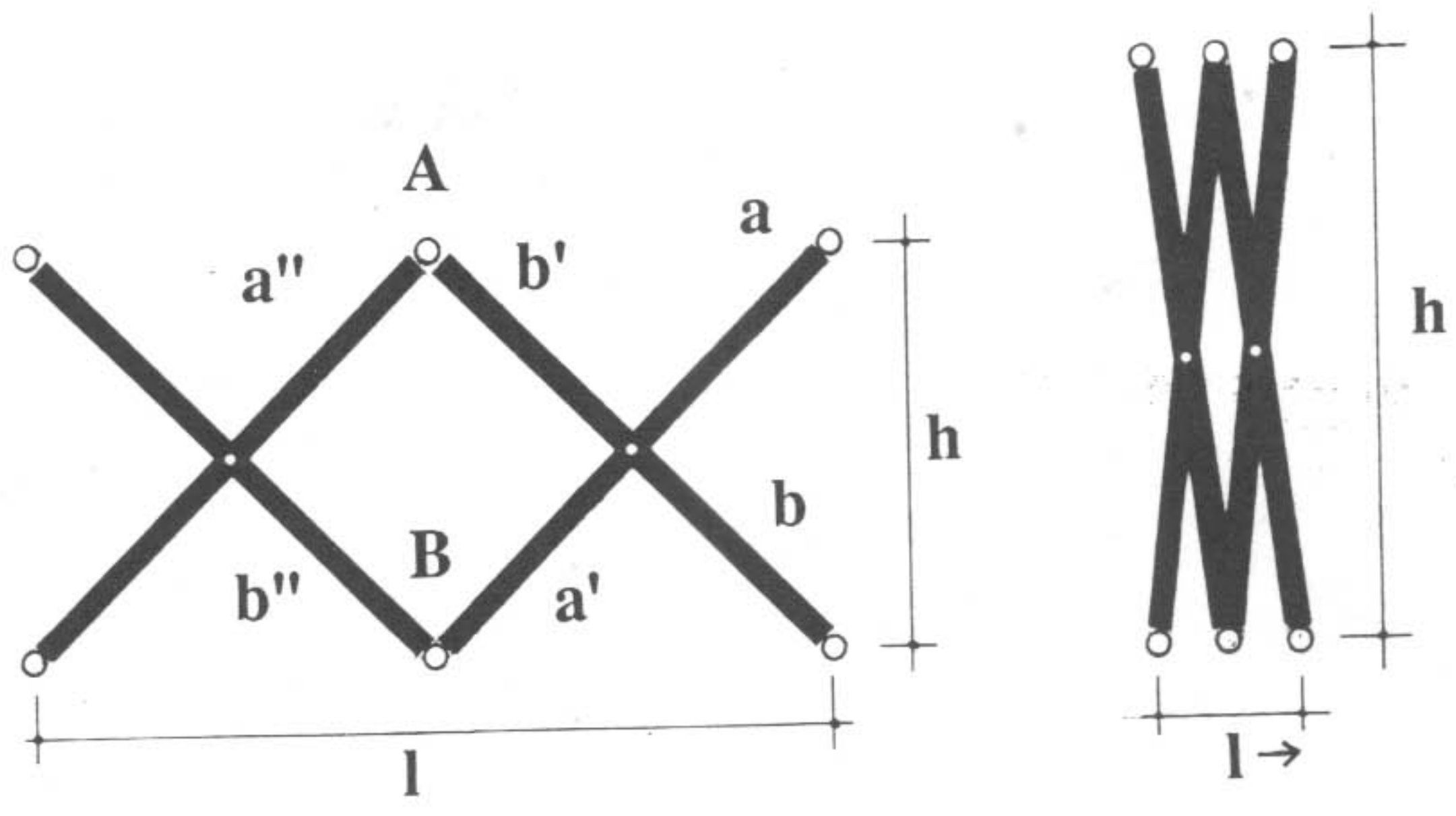

Figure 10

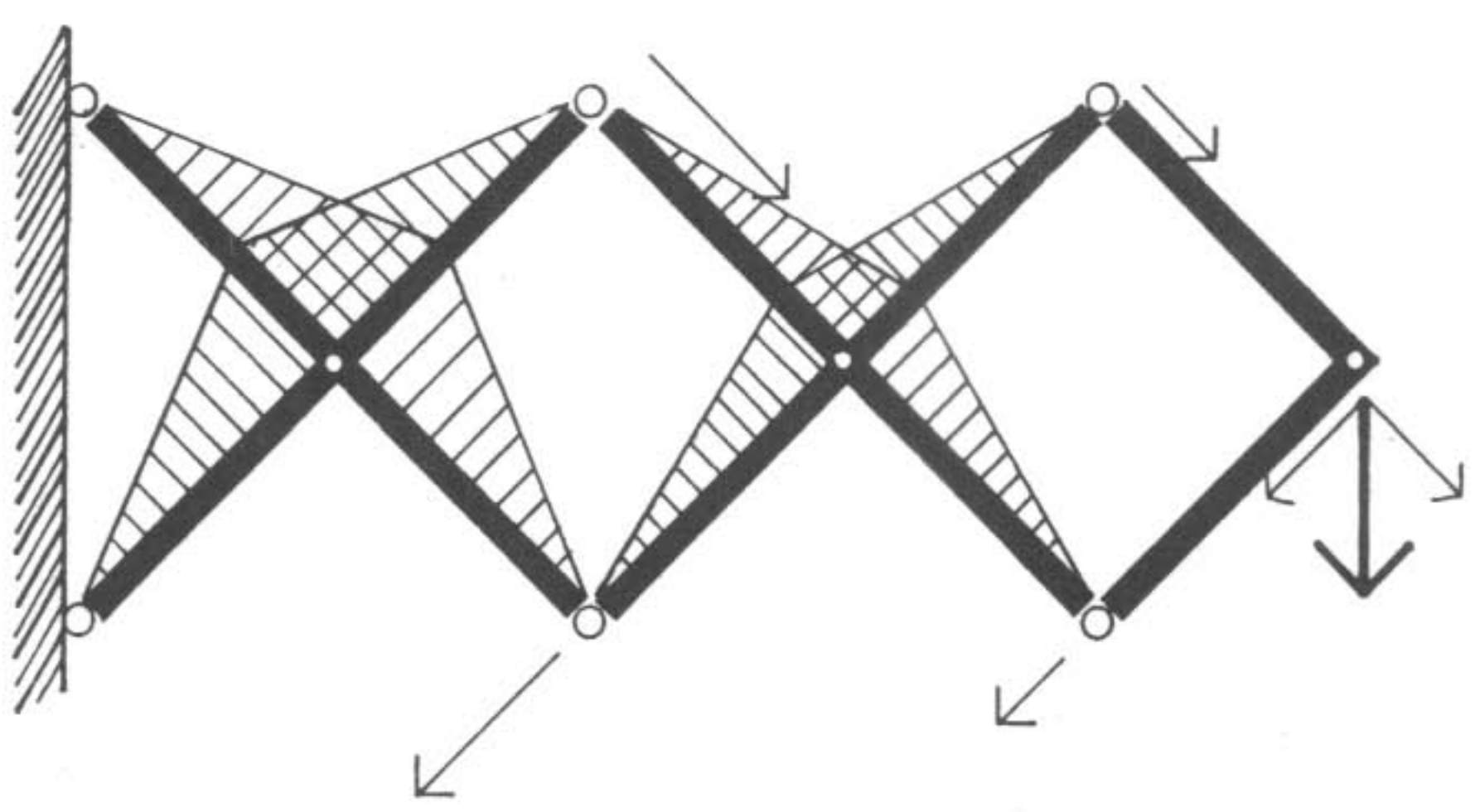

Figure 11

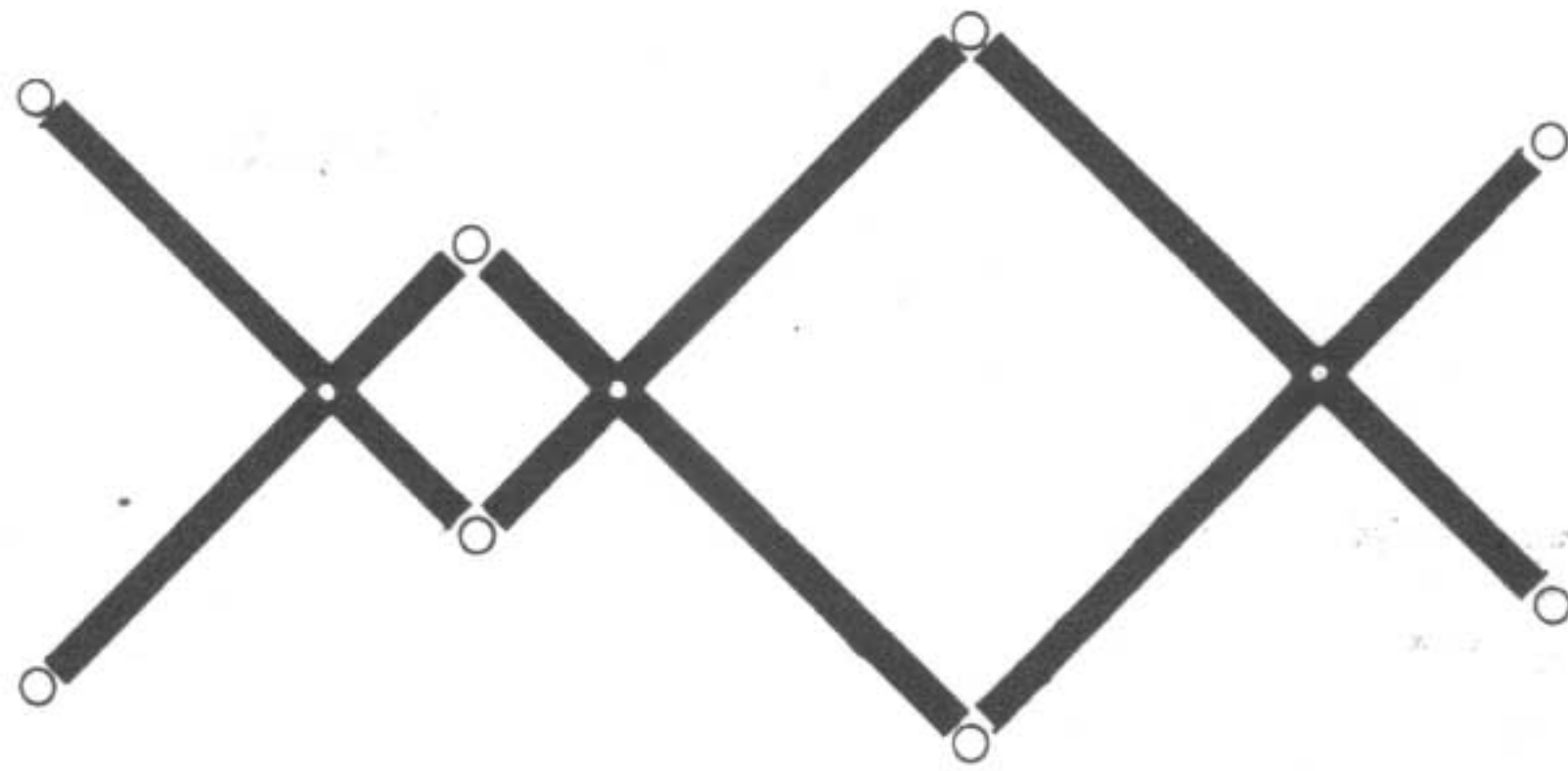

Figure 12

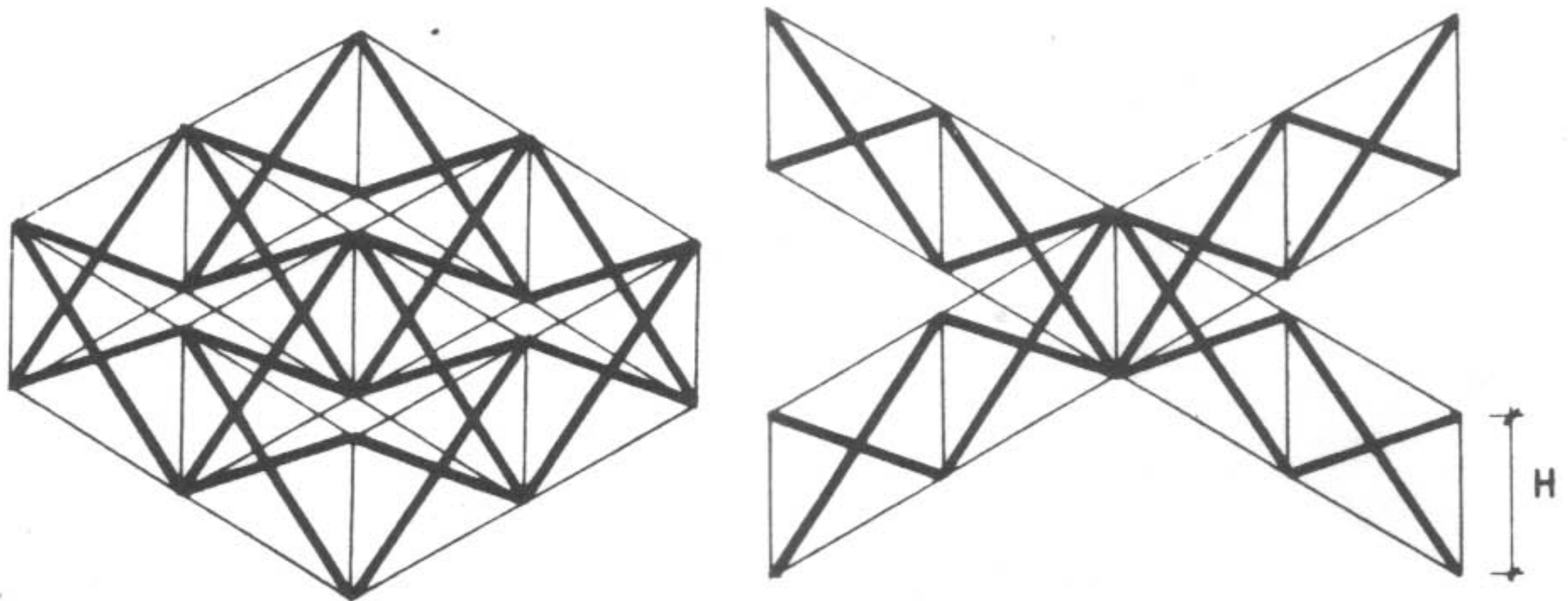

Figure 13

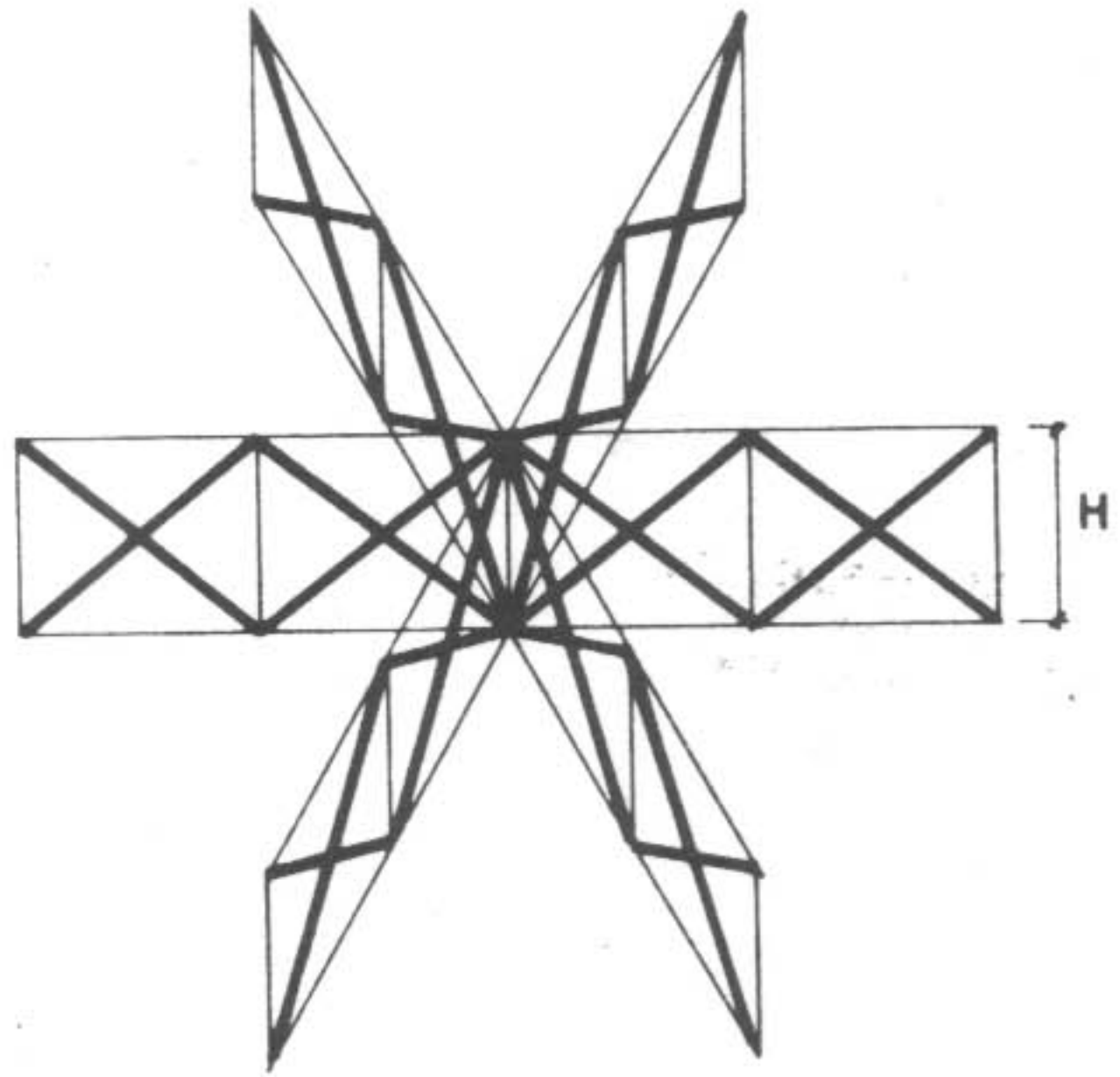

Figure 14

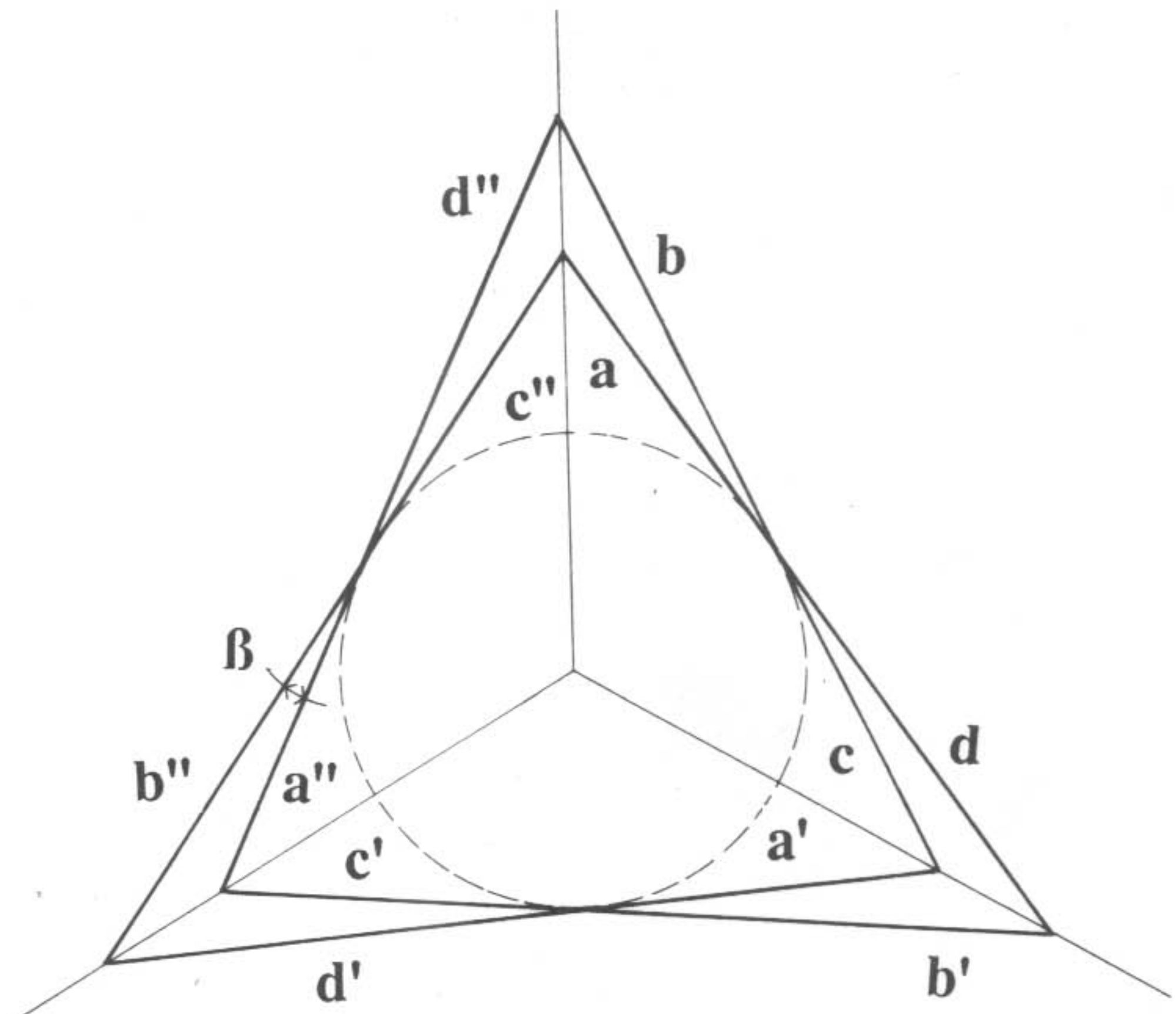

Figure 15

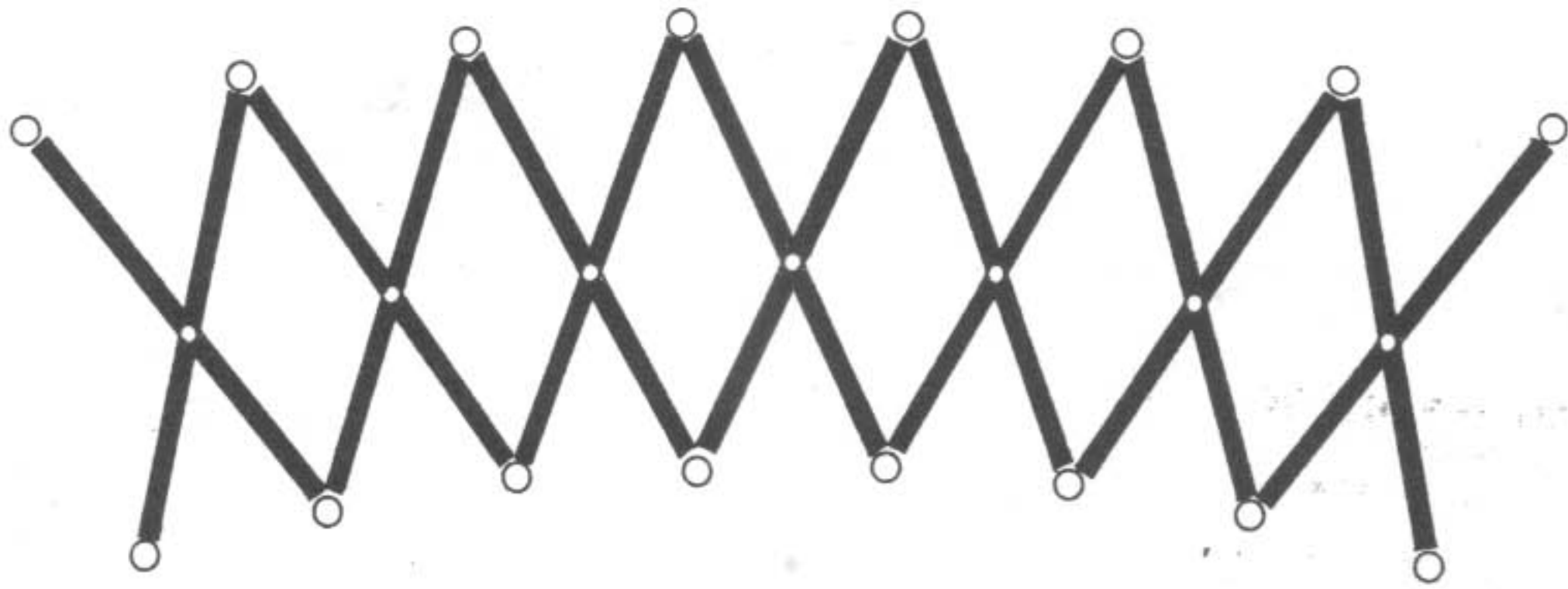

Figure 16

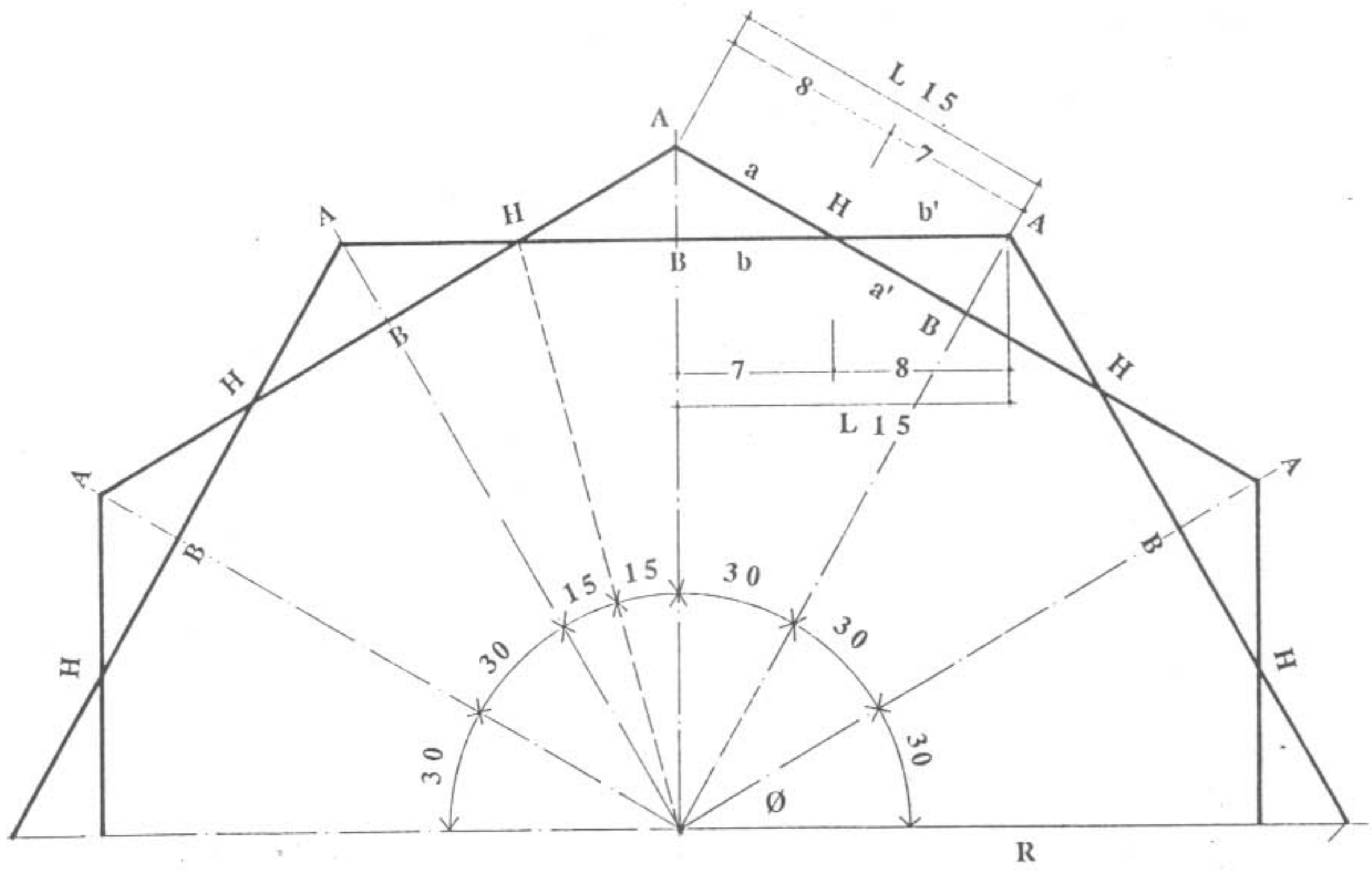

Figure 17



Figure 18

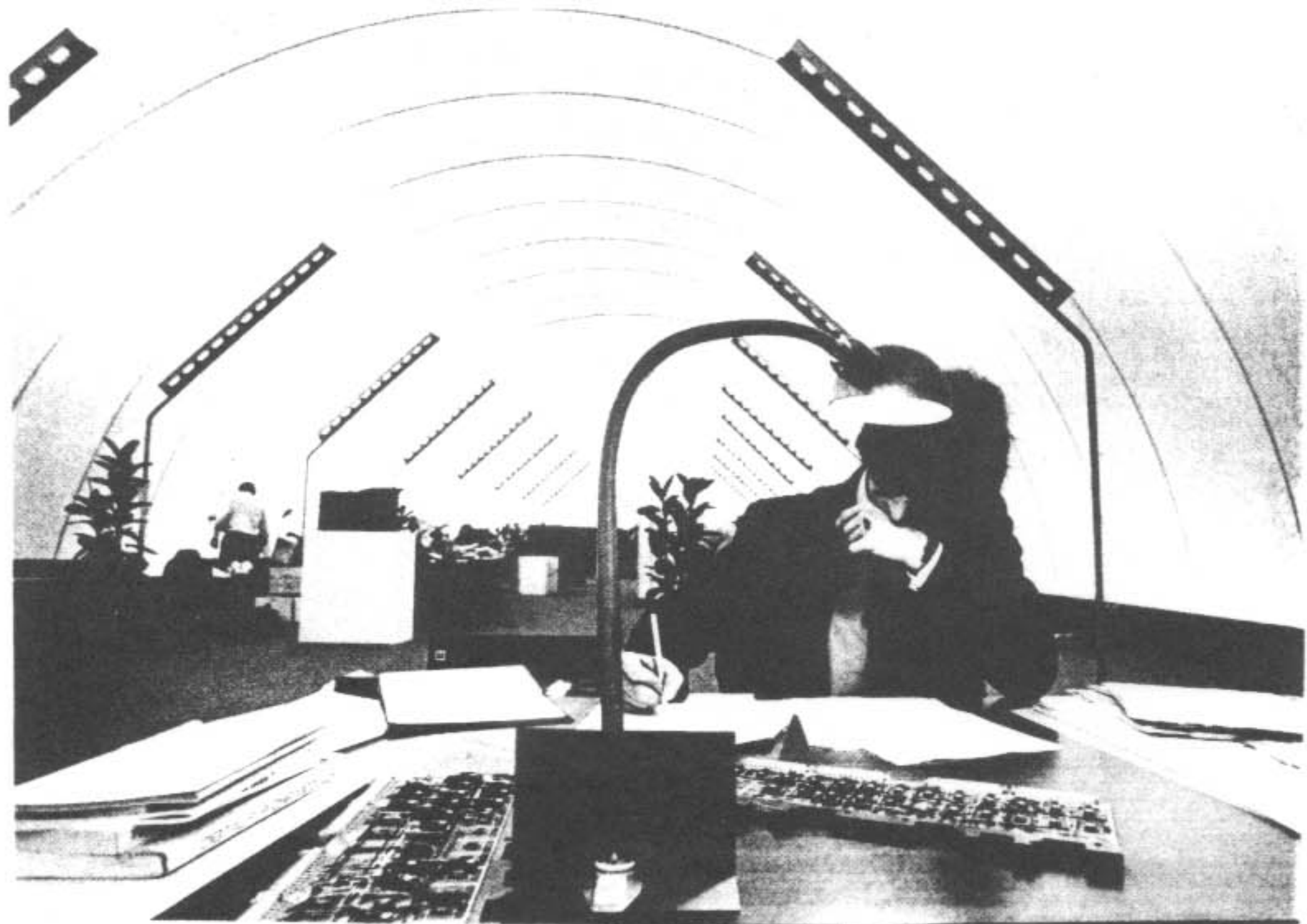

Figure 19

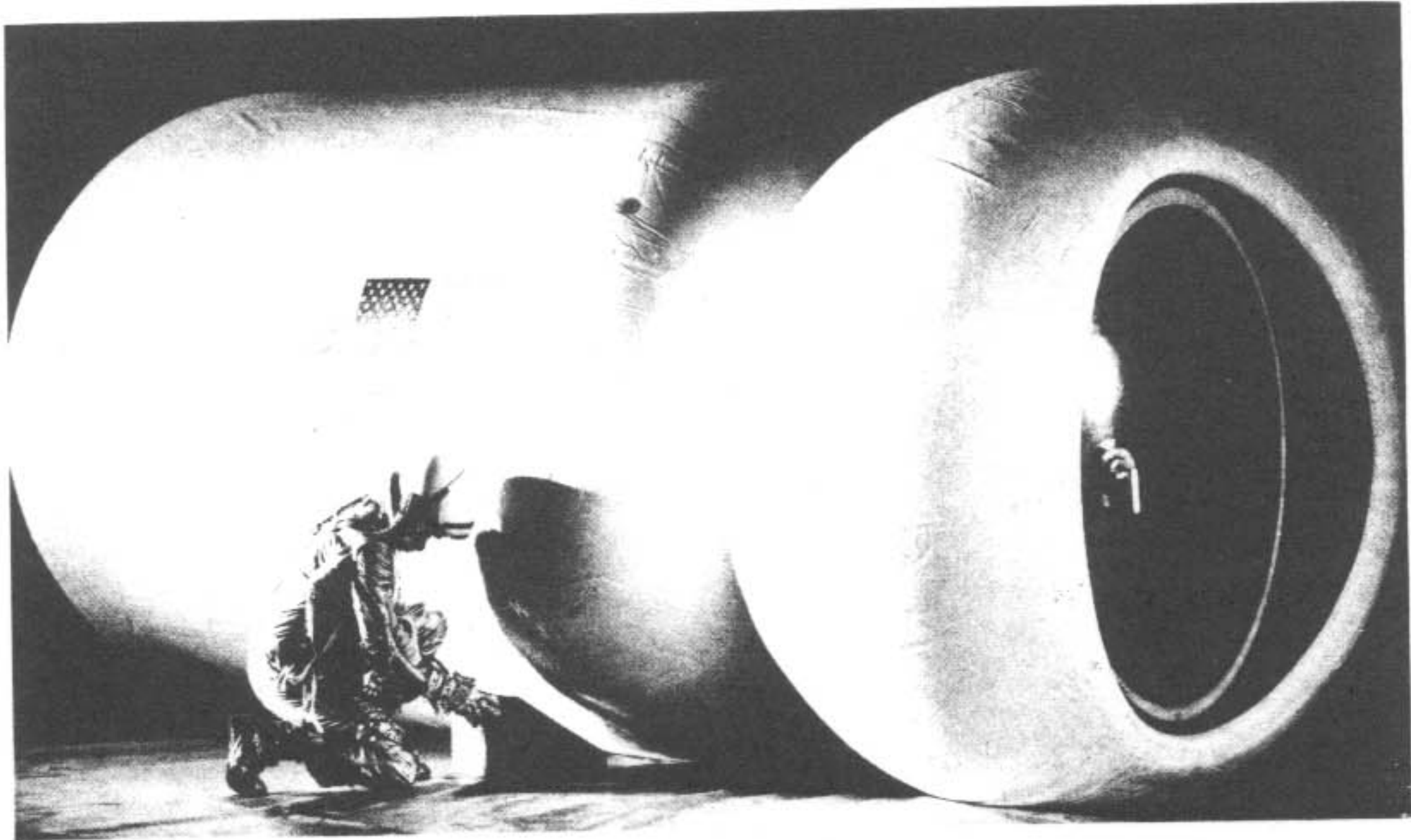

Figure 20

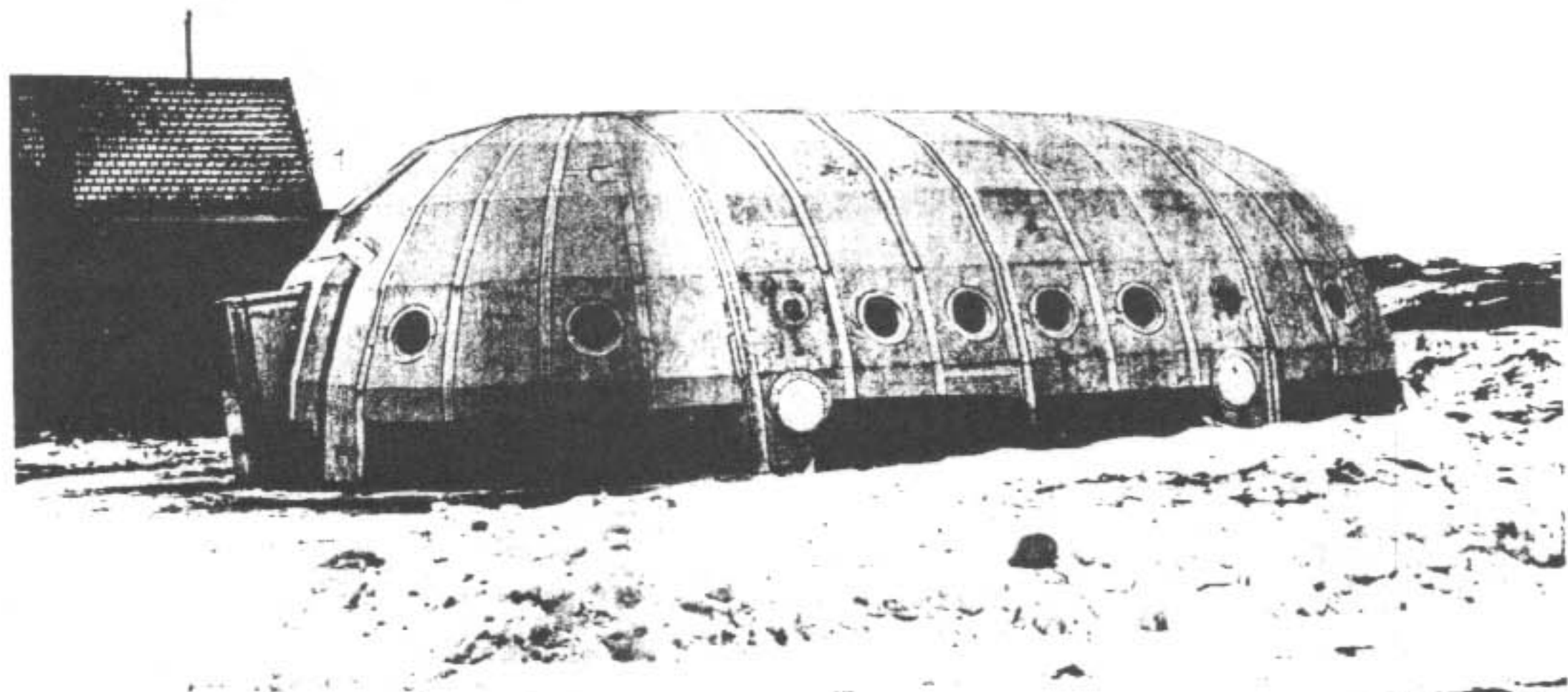

Figure 21

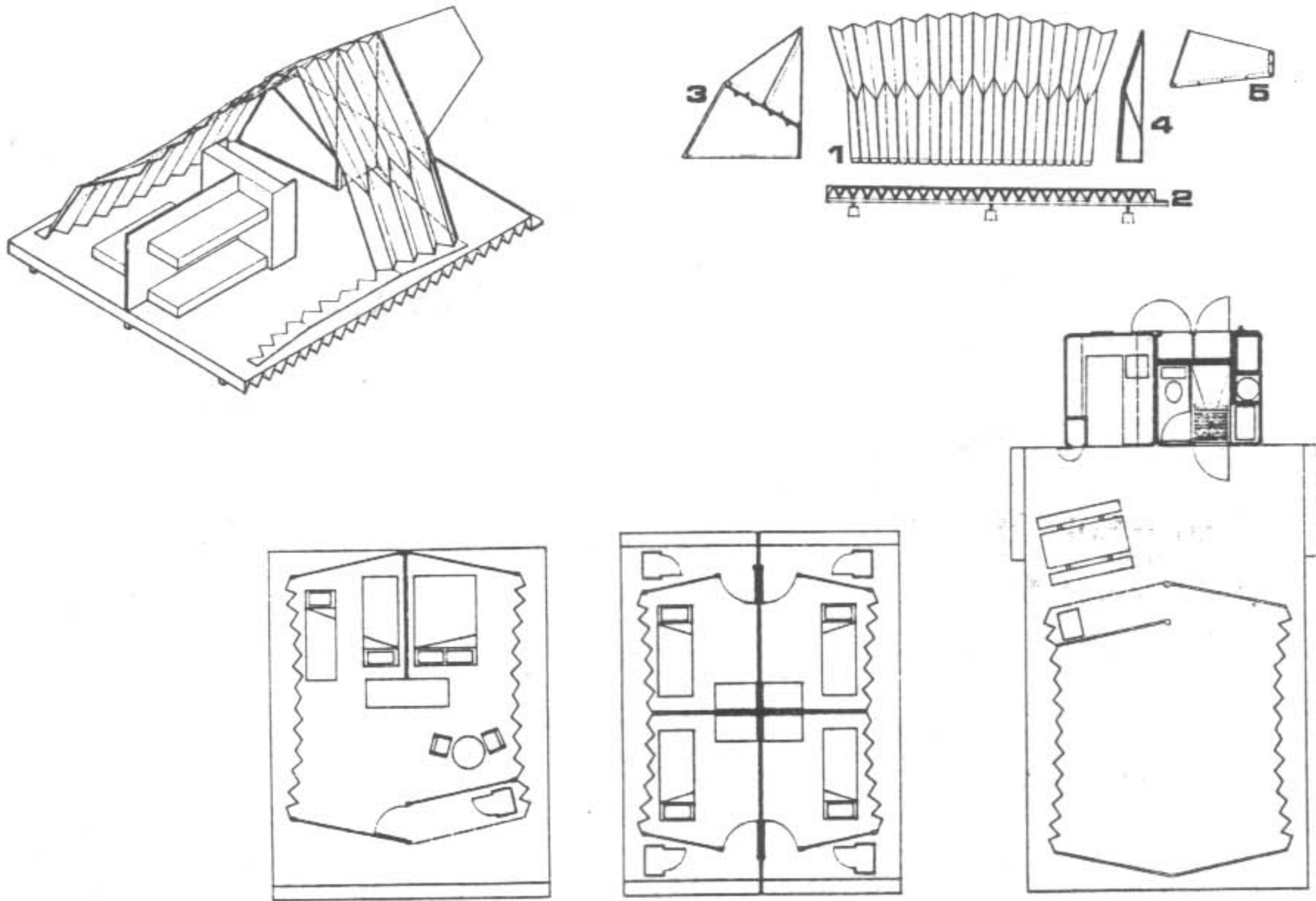

Figure 22

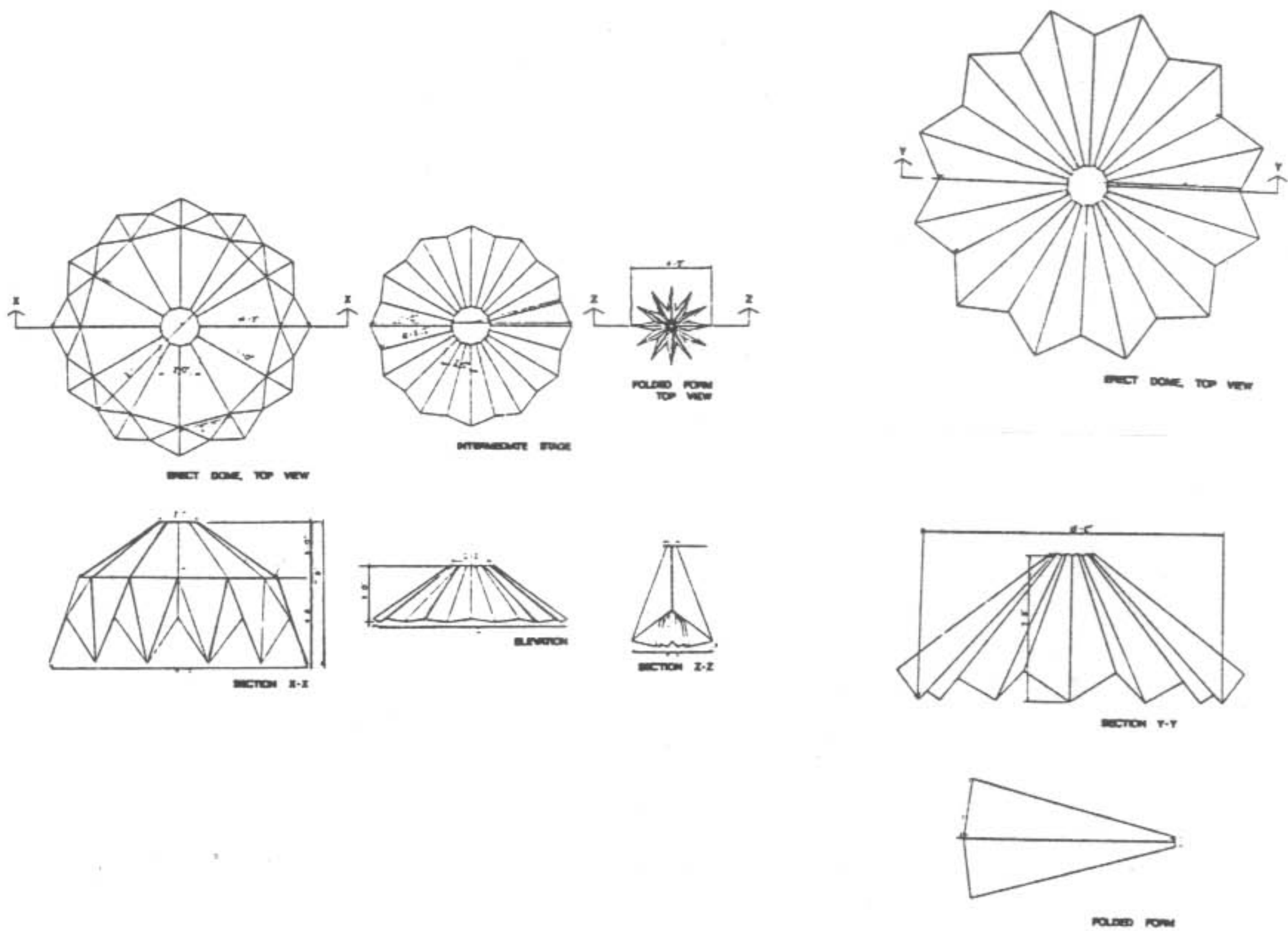

Figure 23

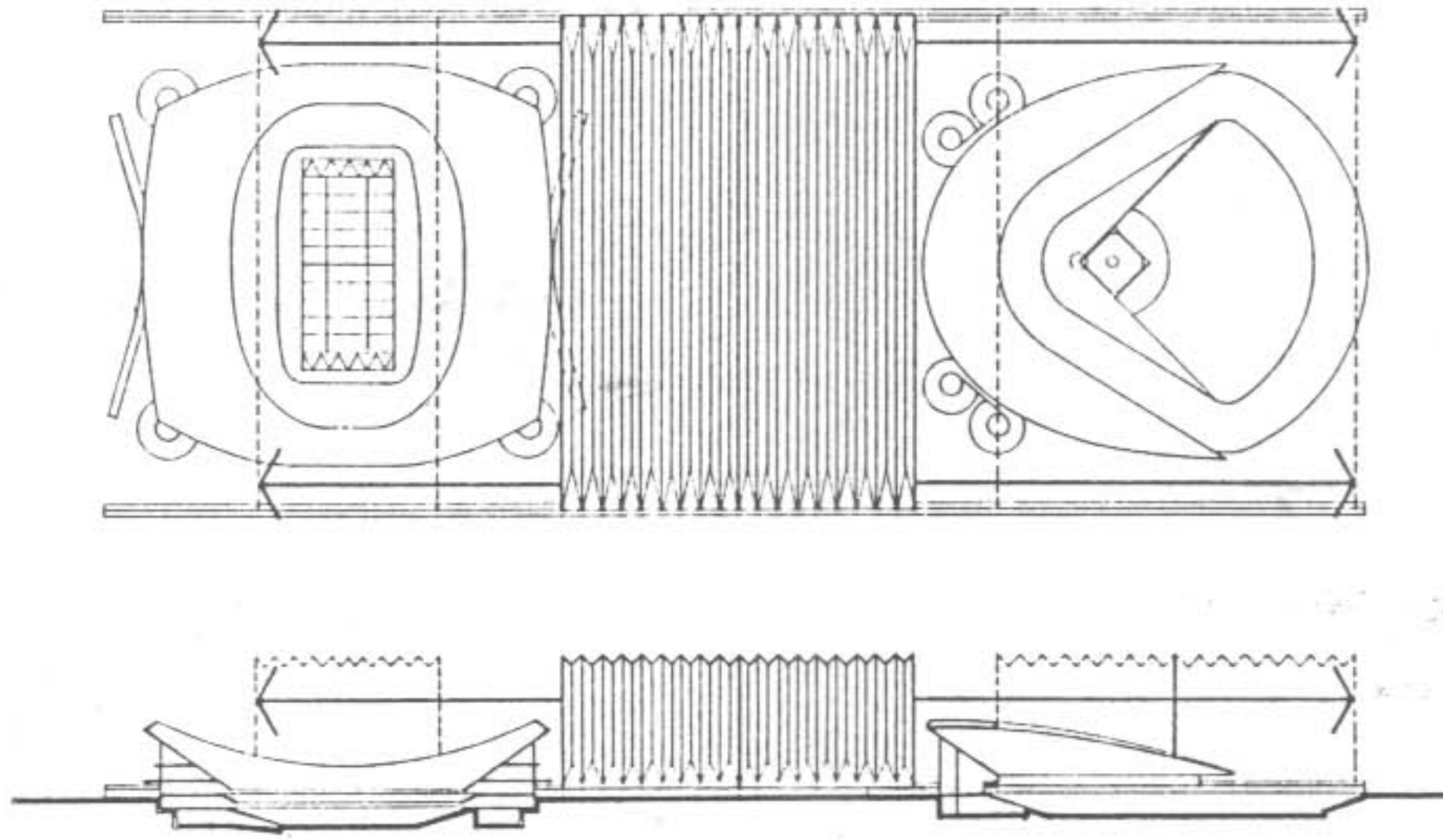

Figure 24

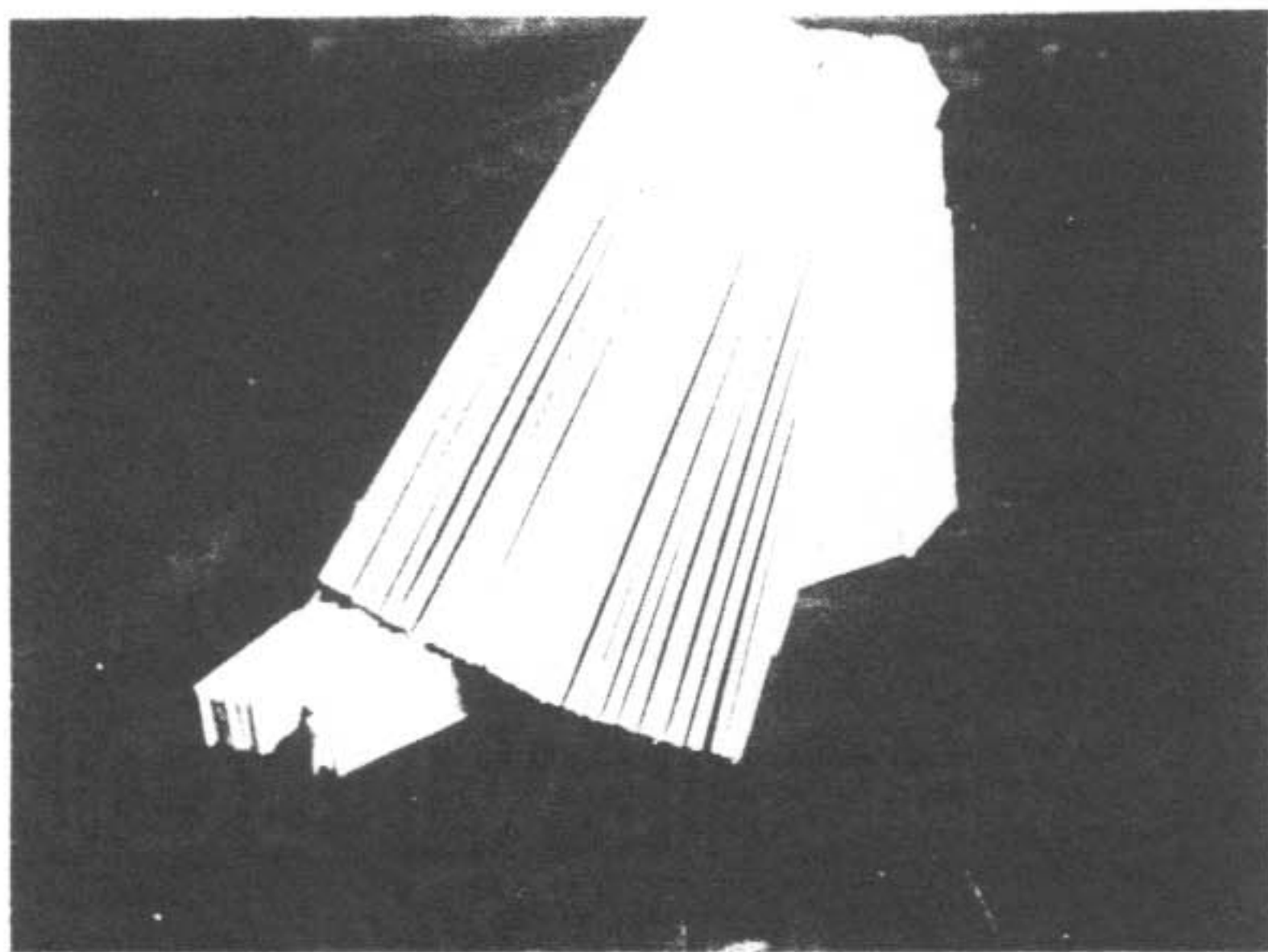

Figure 25

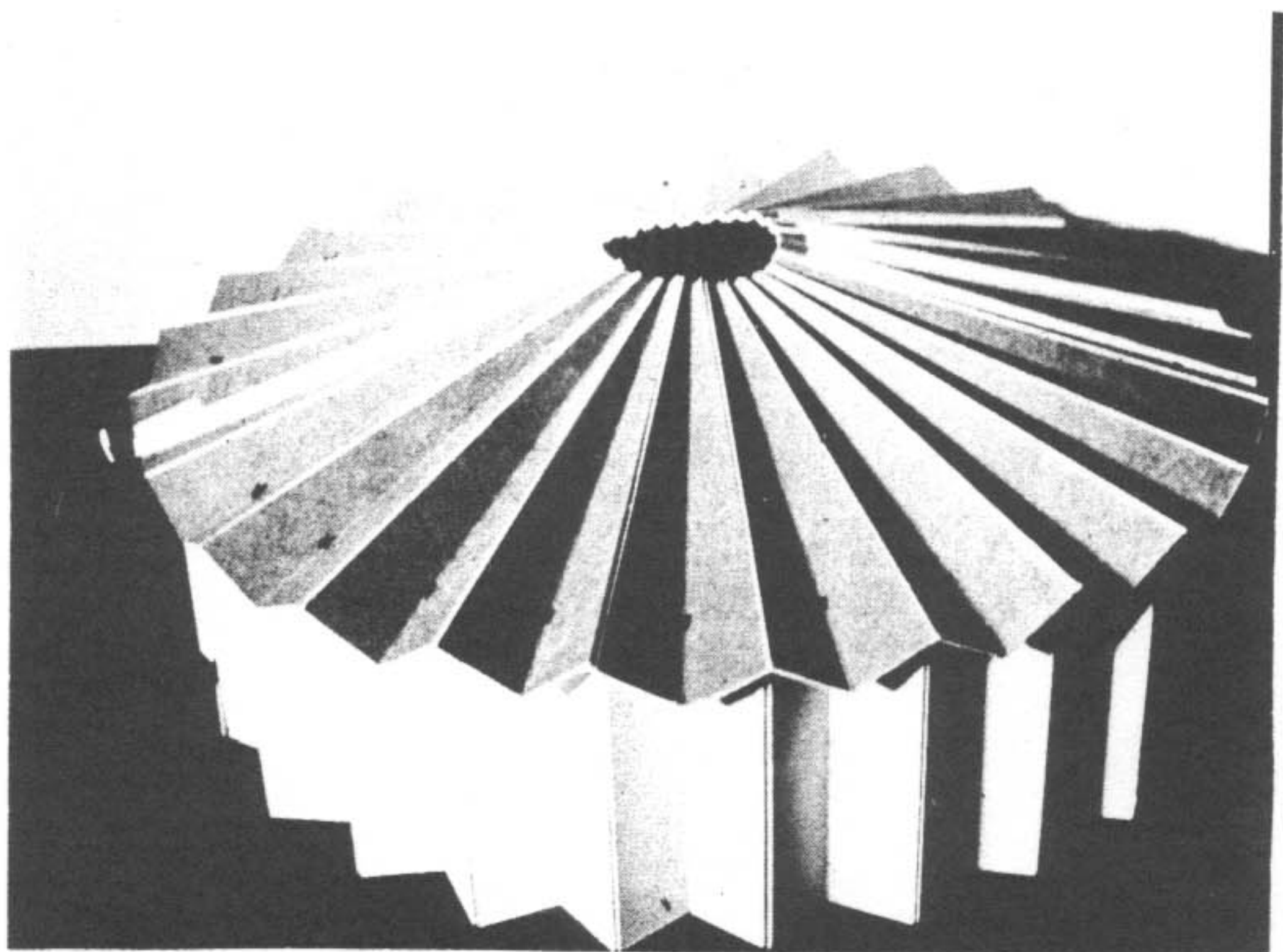
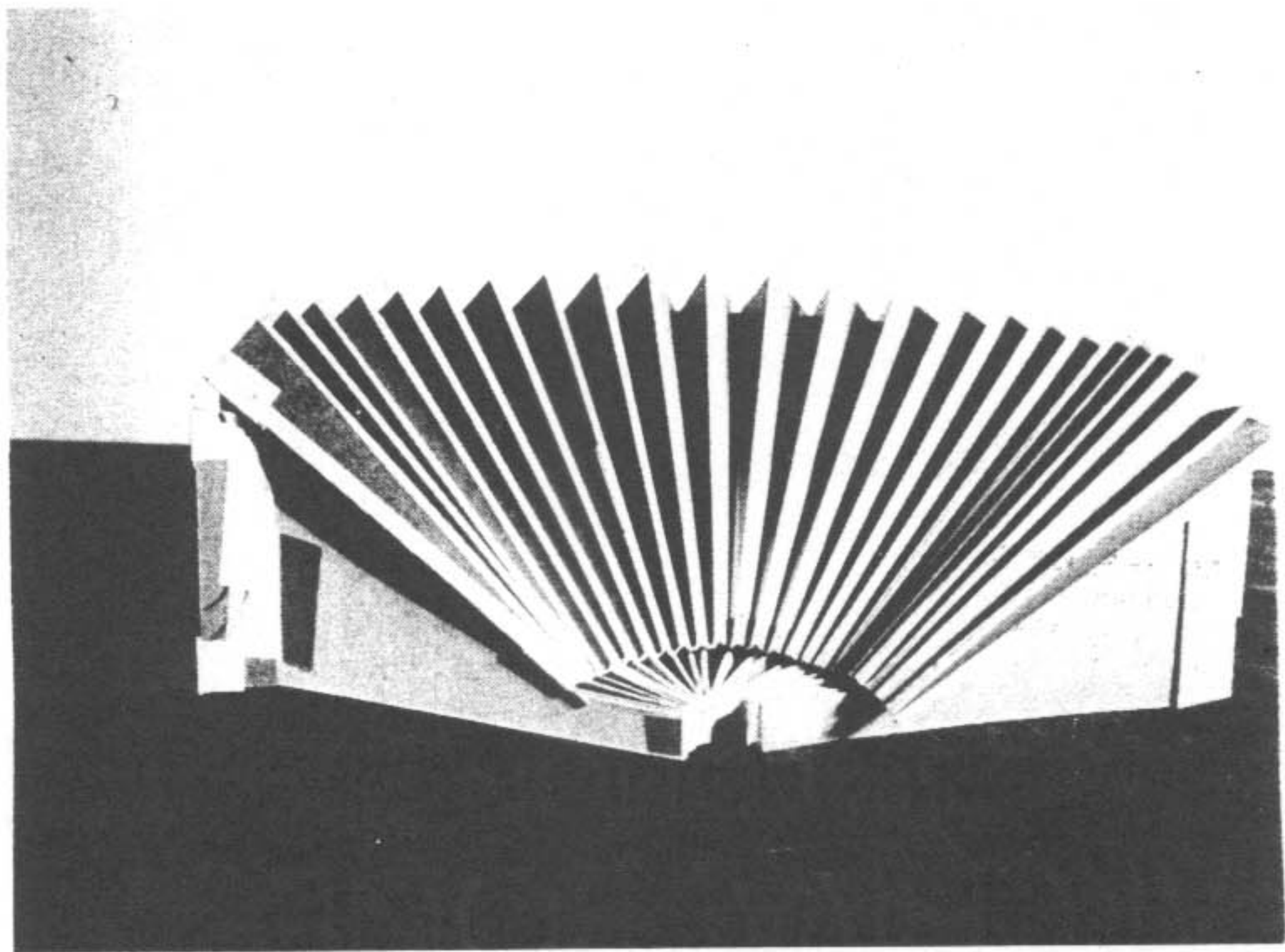

Figure 25

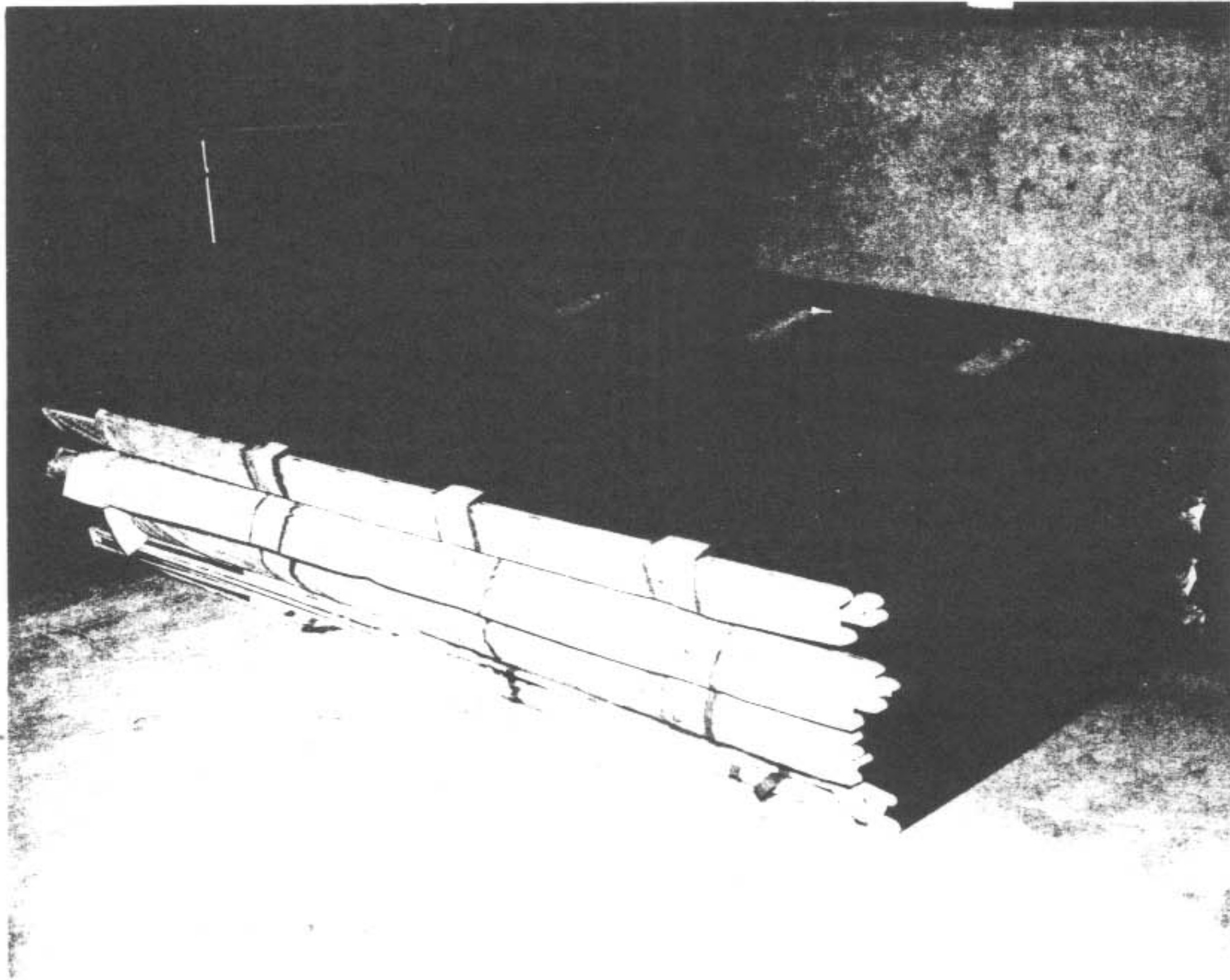
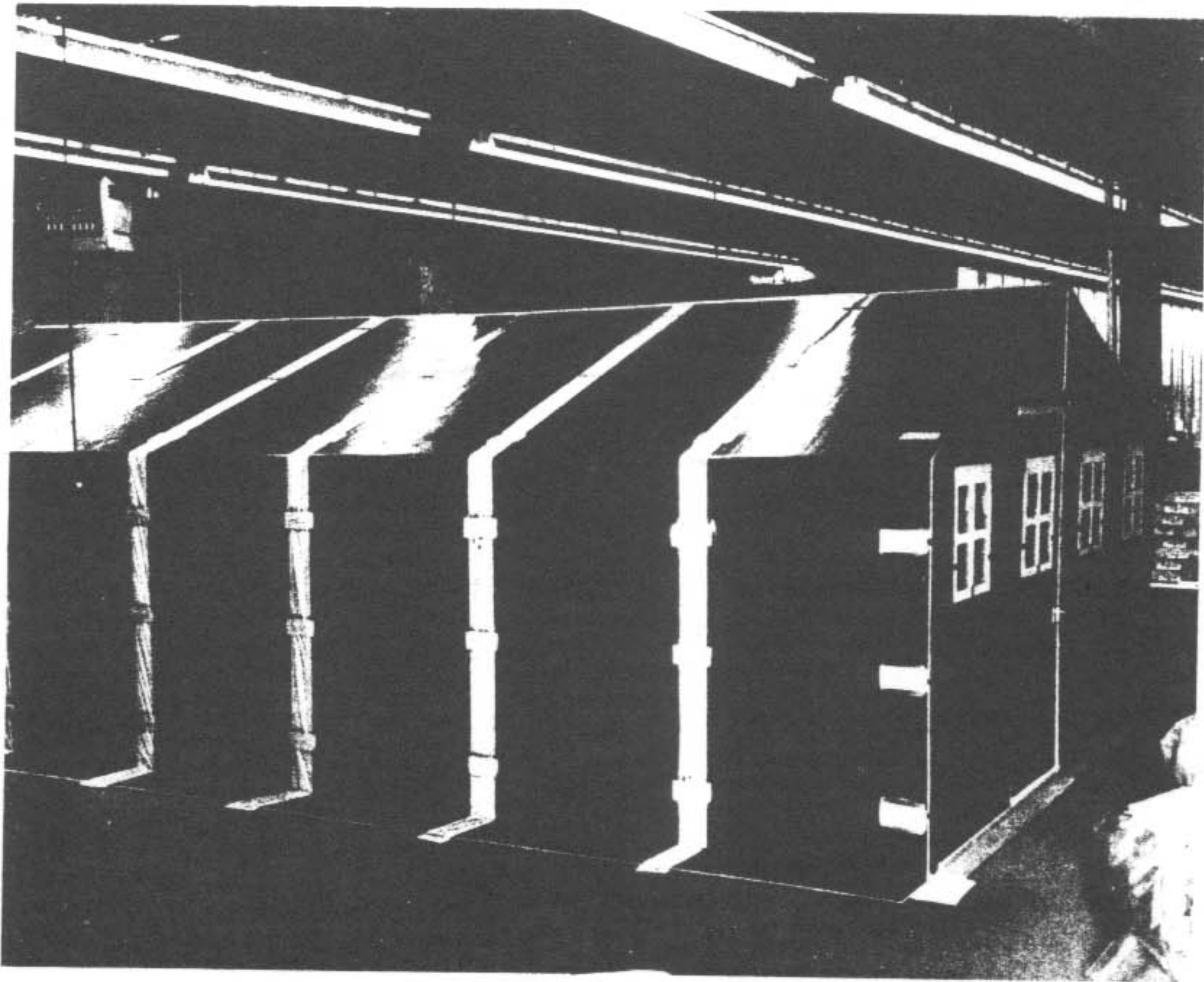

Figure 26

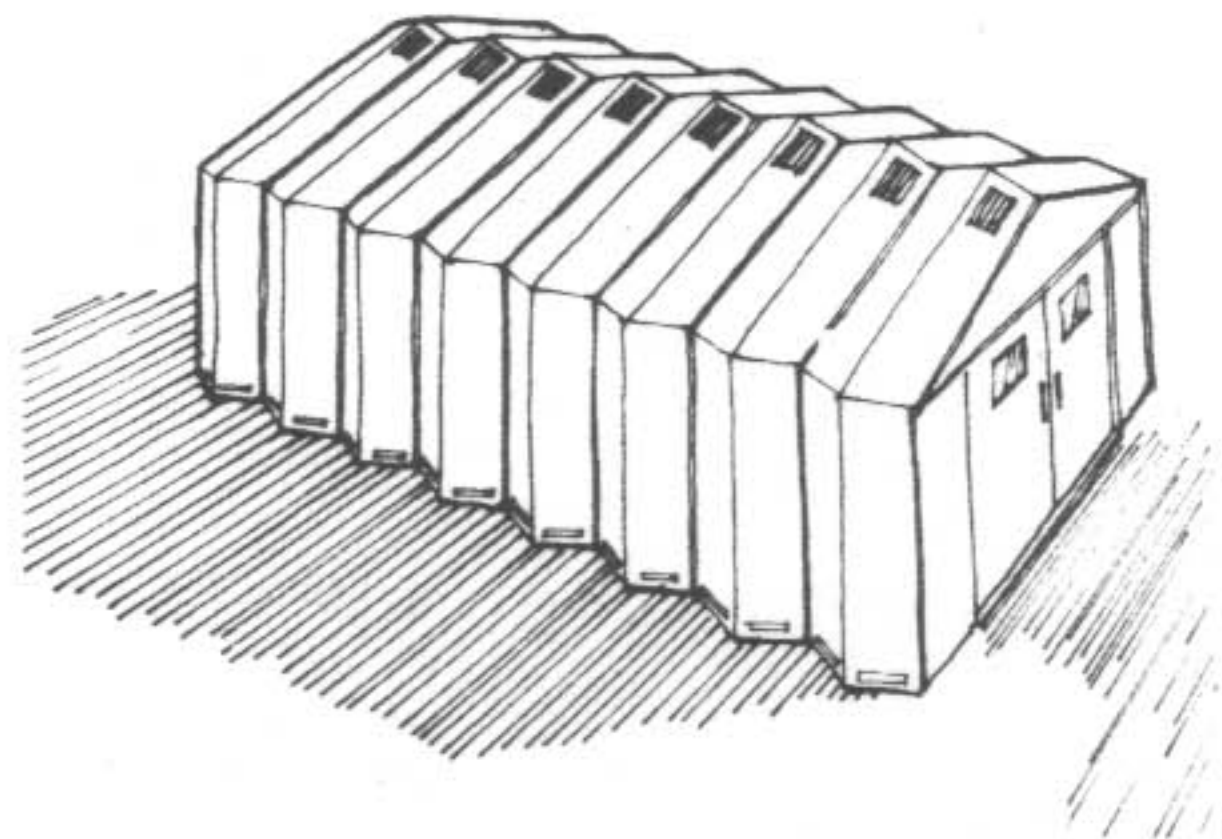
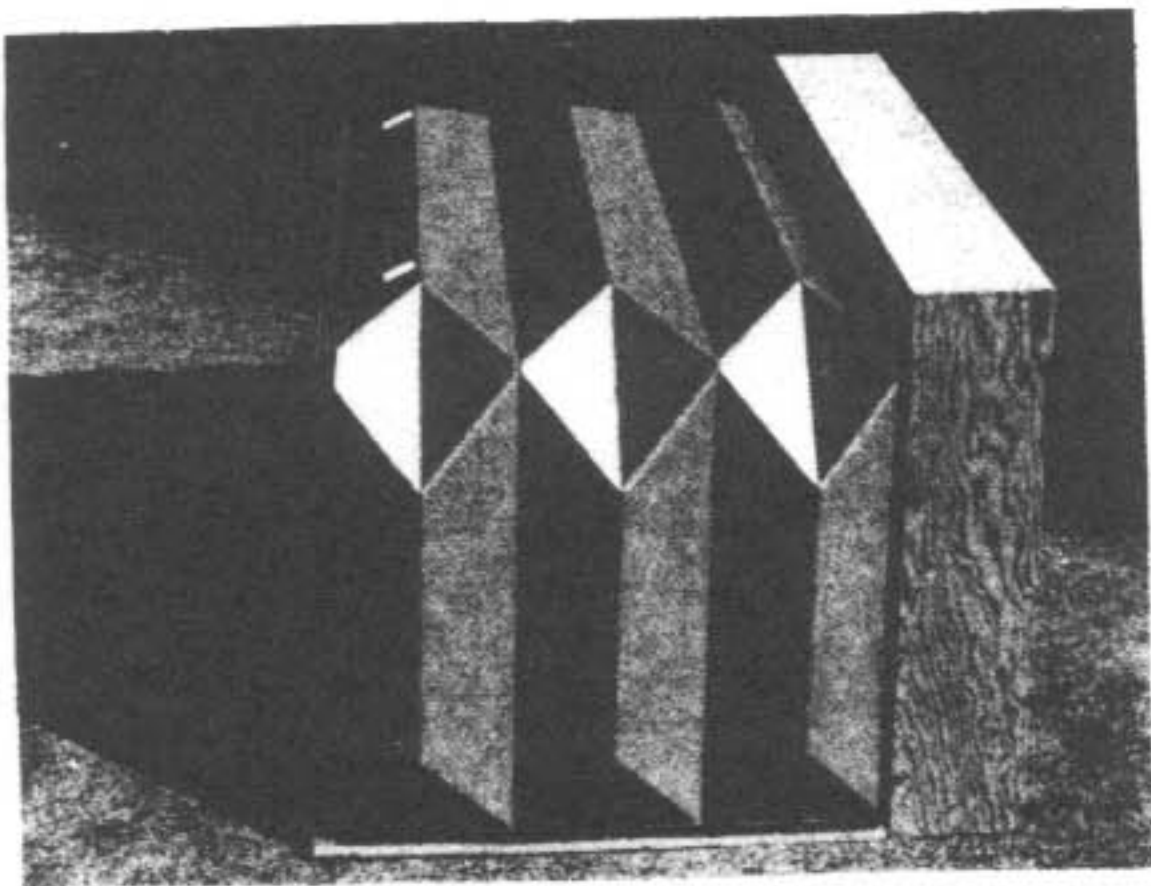
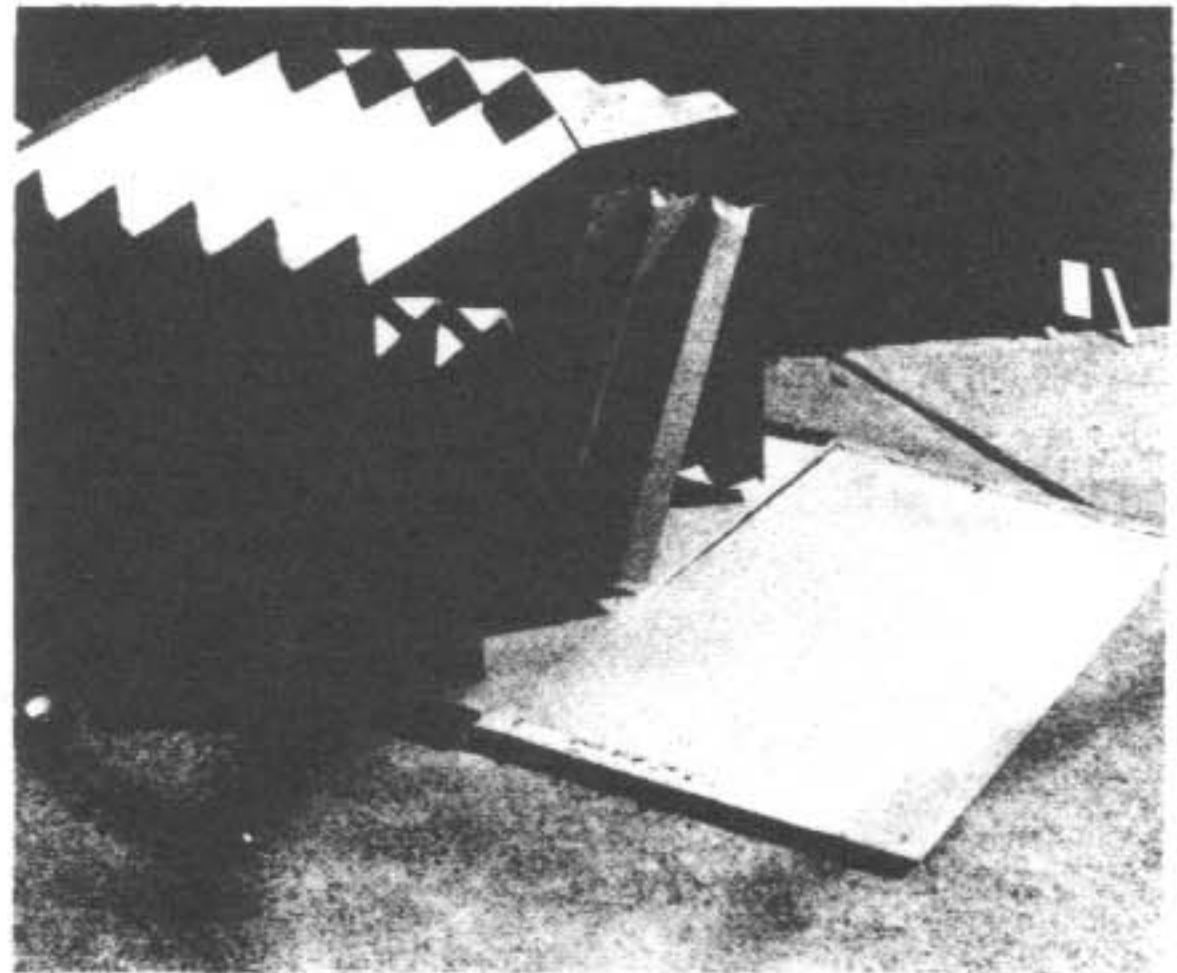
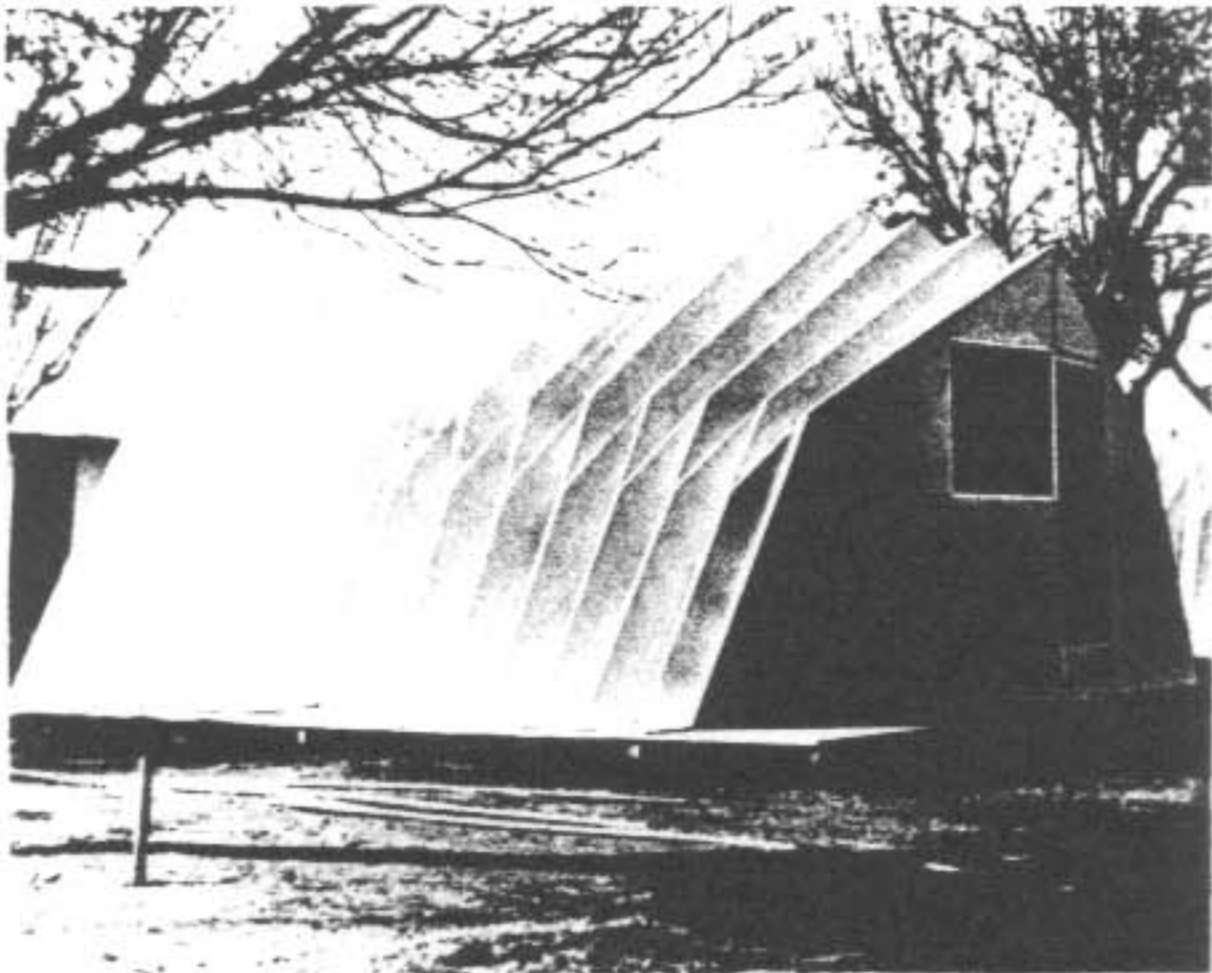

Figure 27

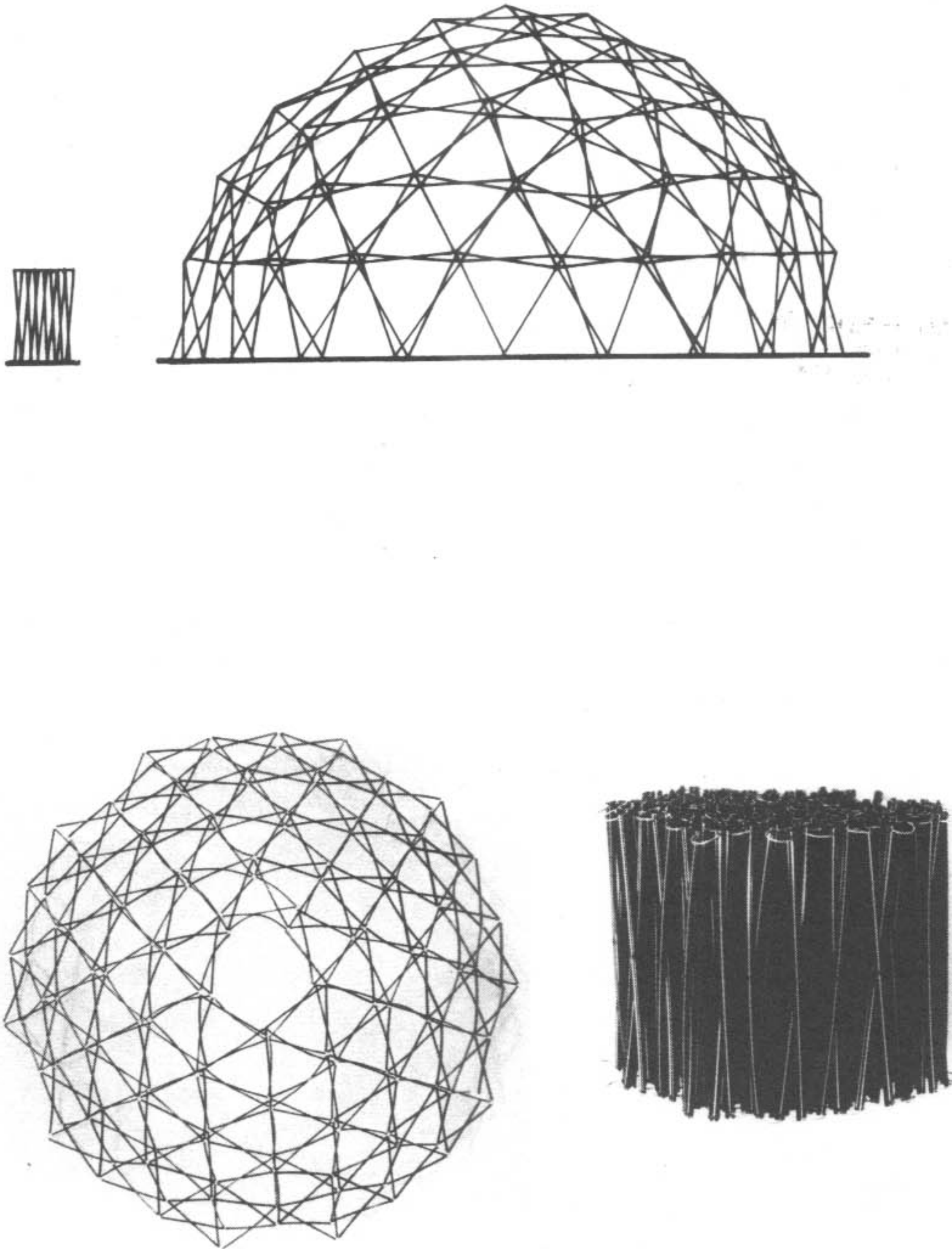

Figure 28

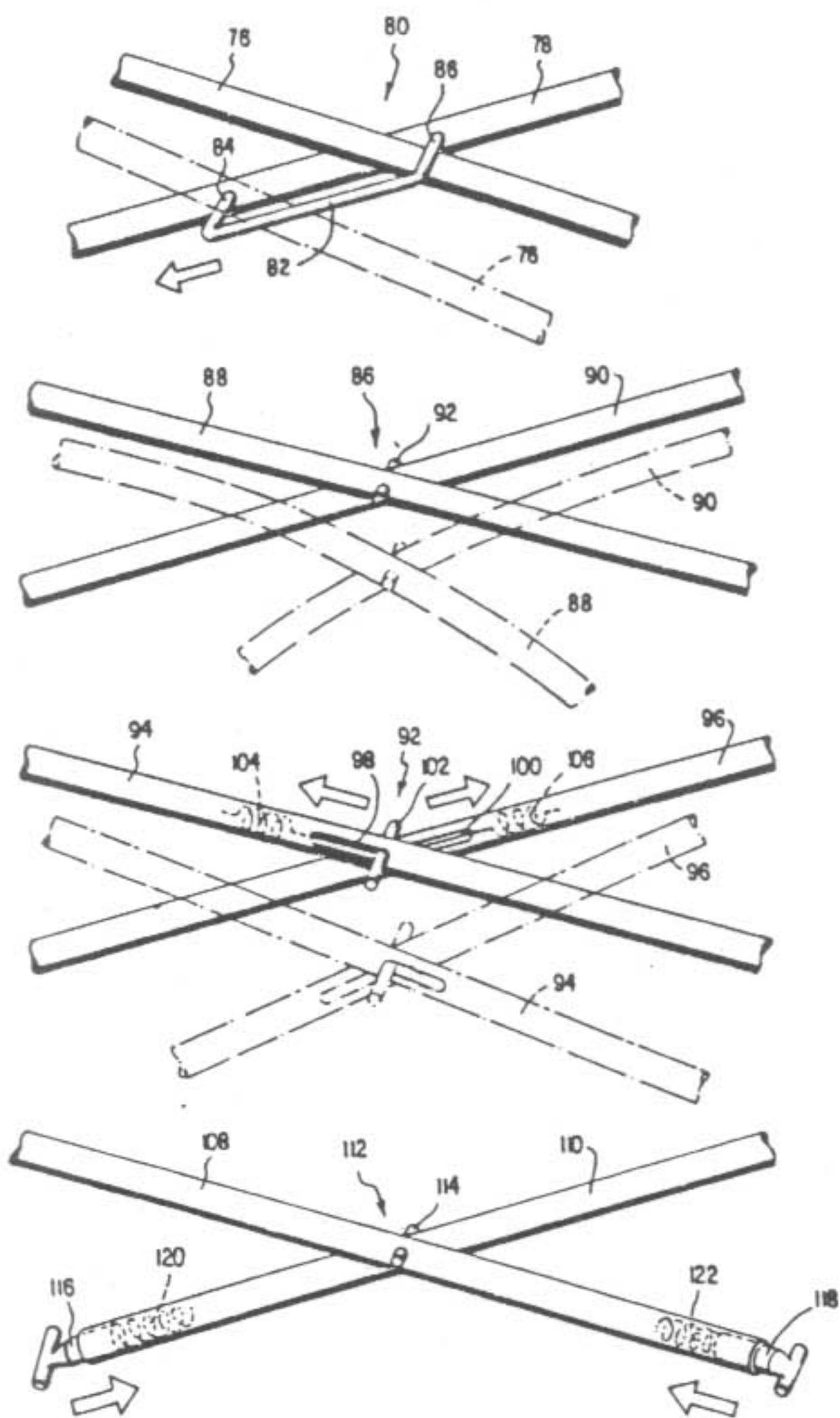
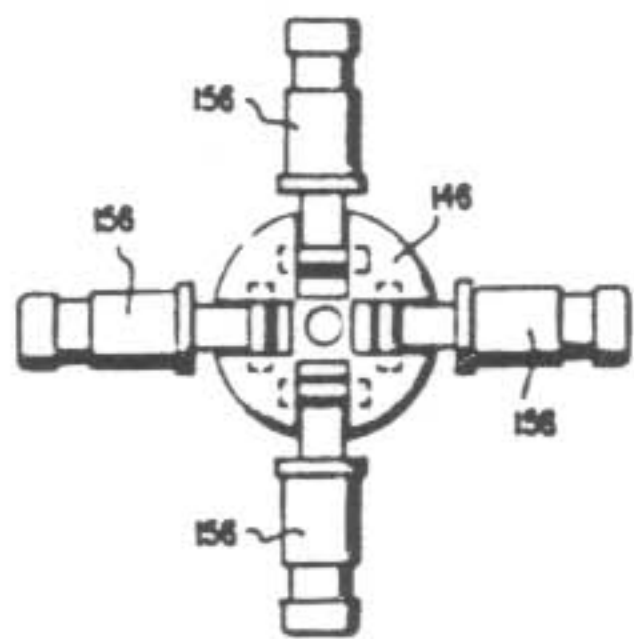
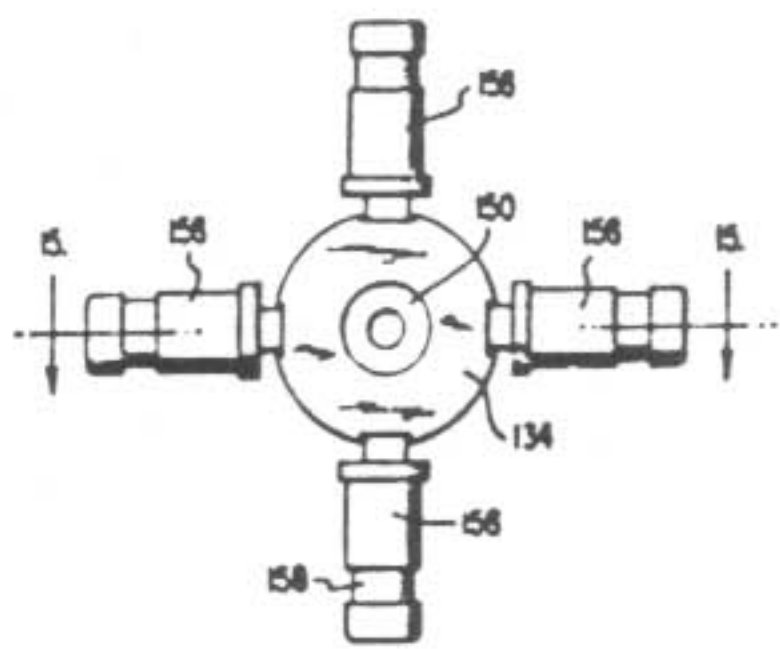
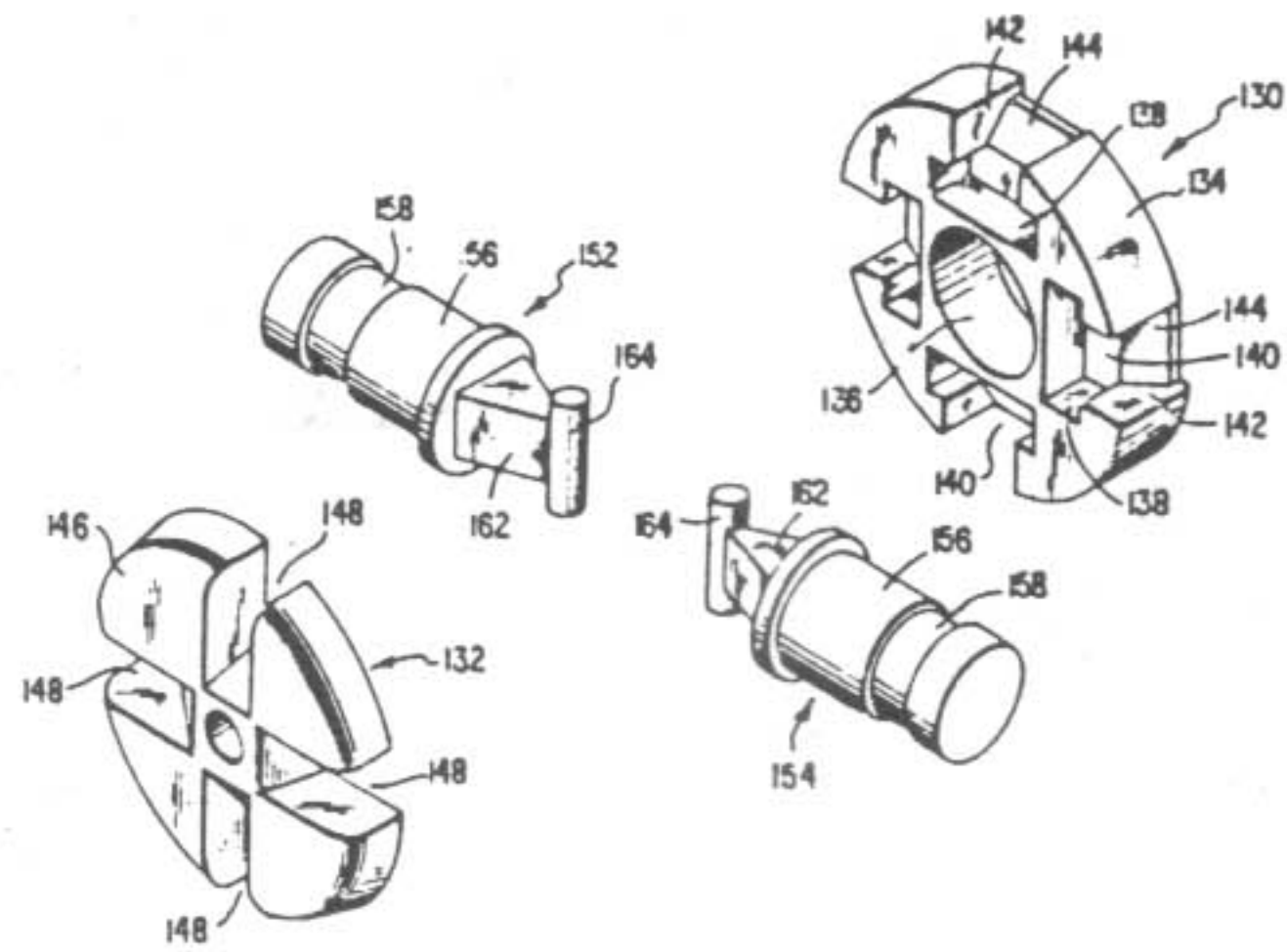

Figure 29

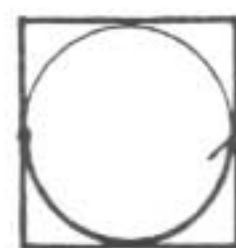
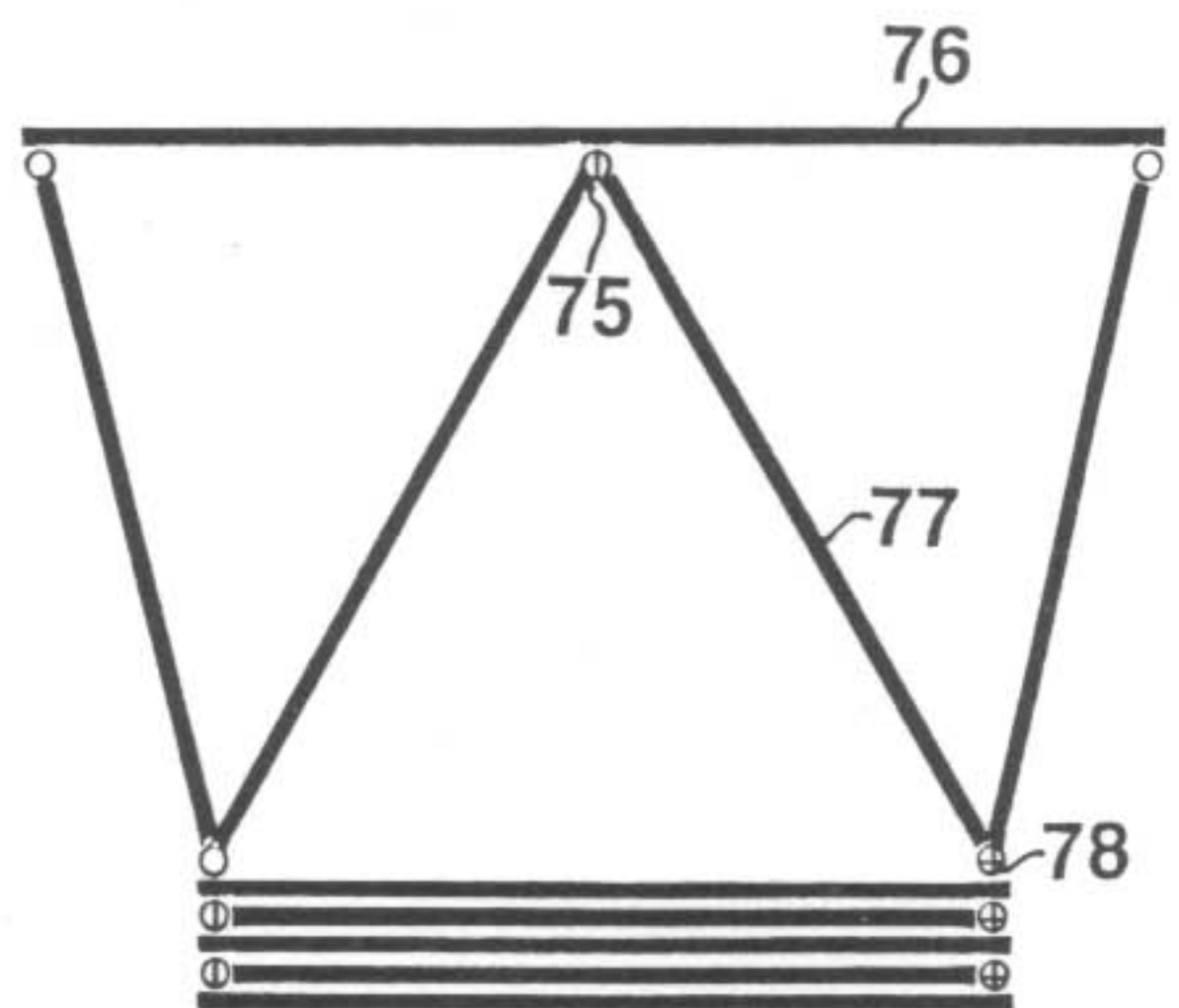
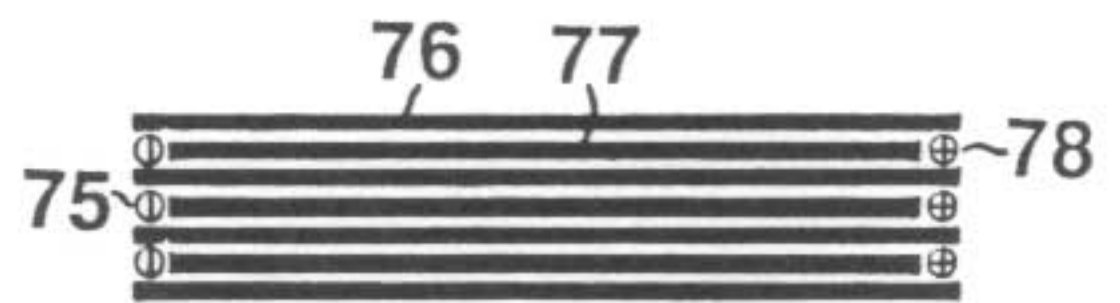
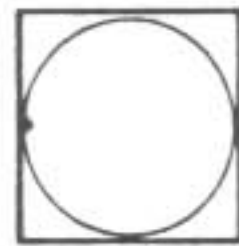
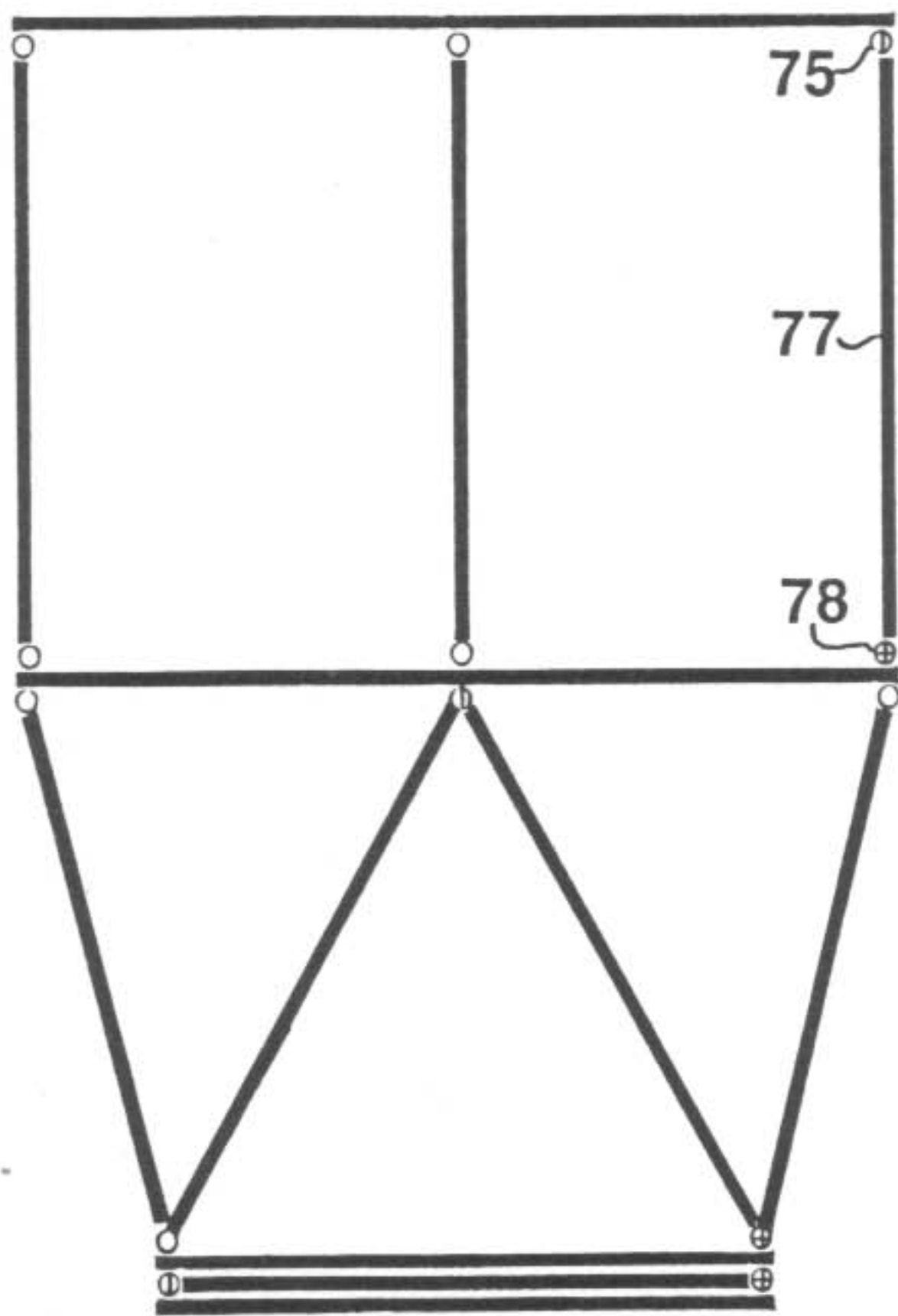

Figure 30

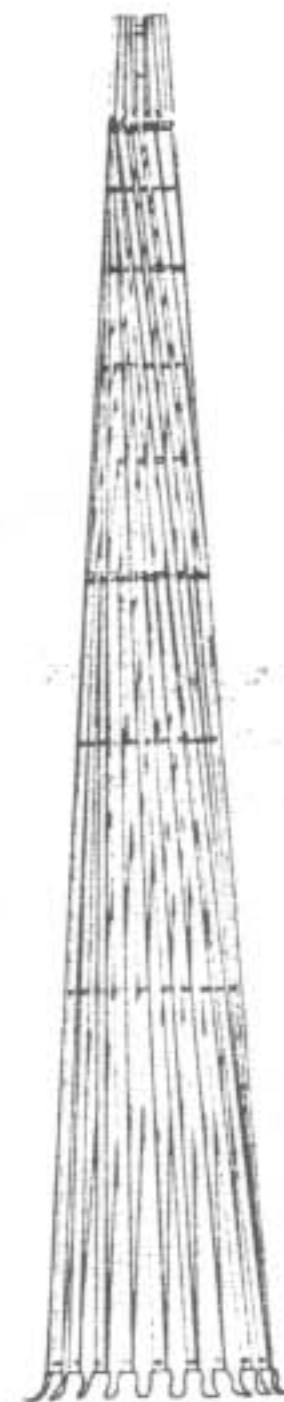
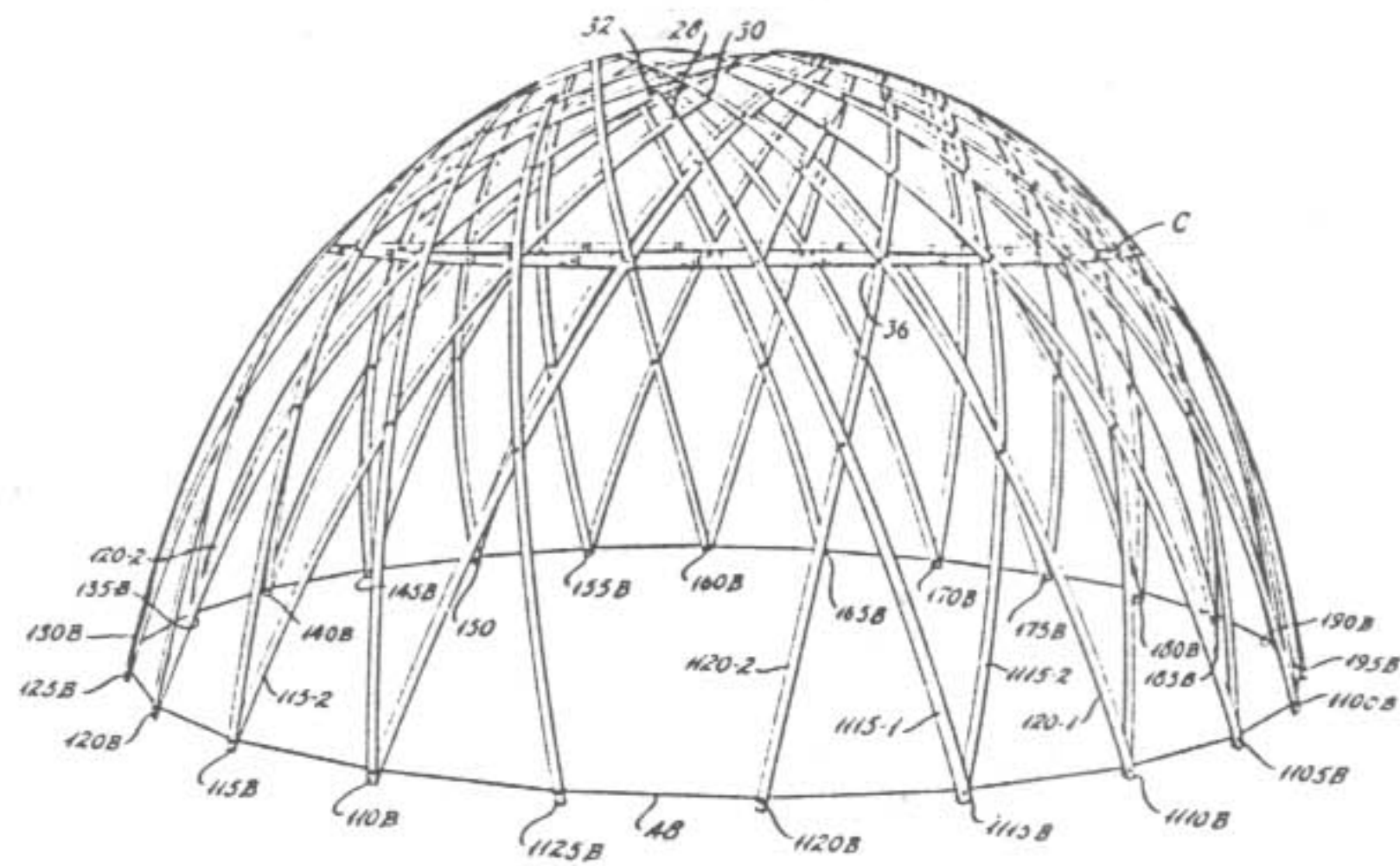

Figure 31

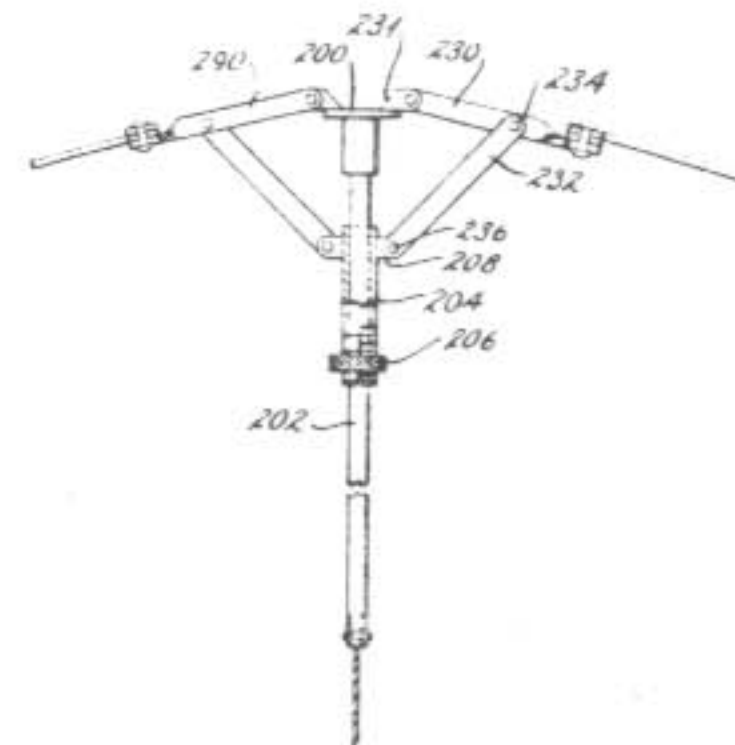
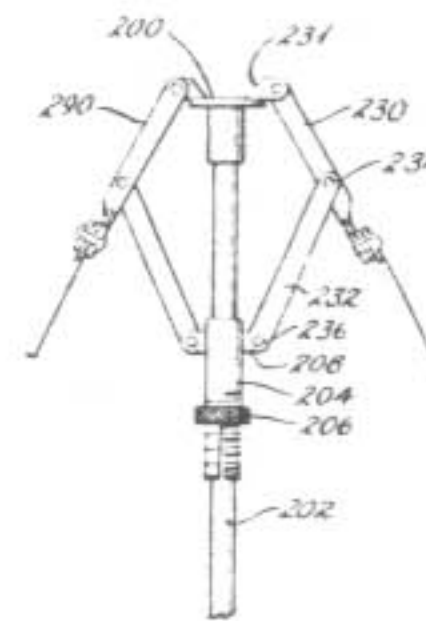
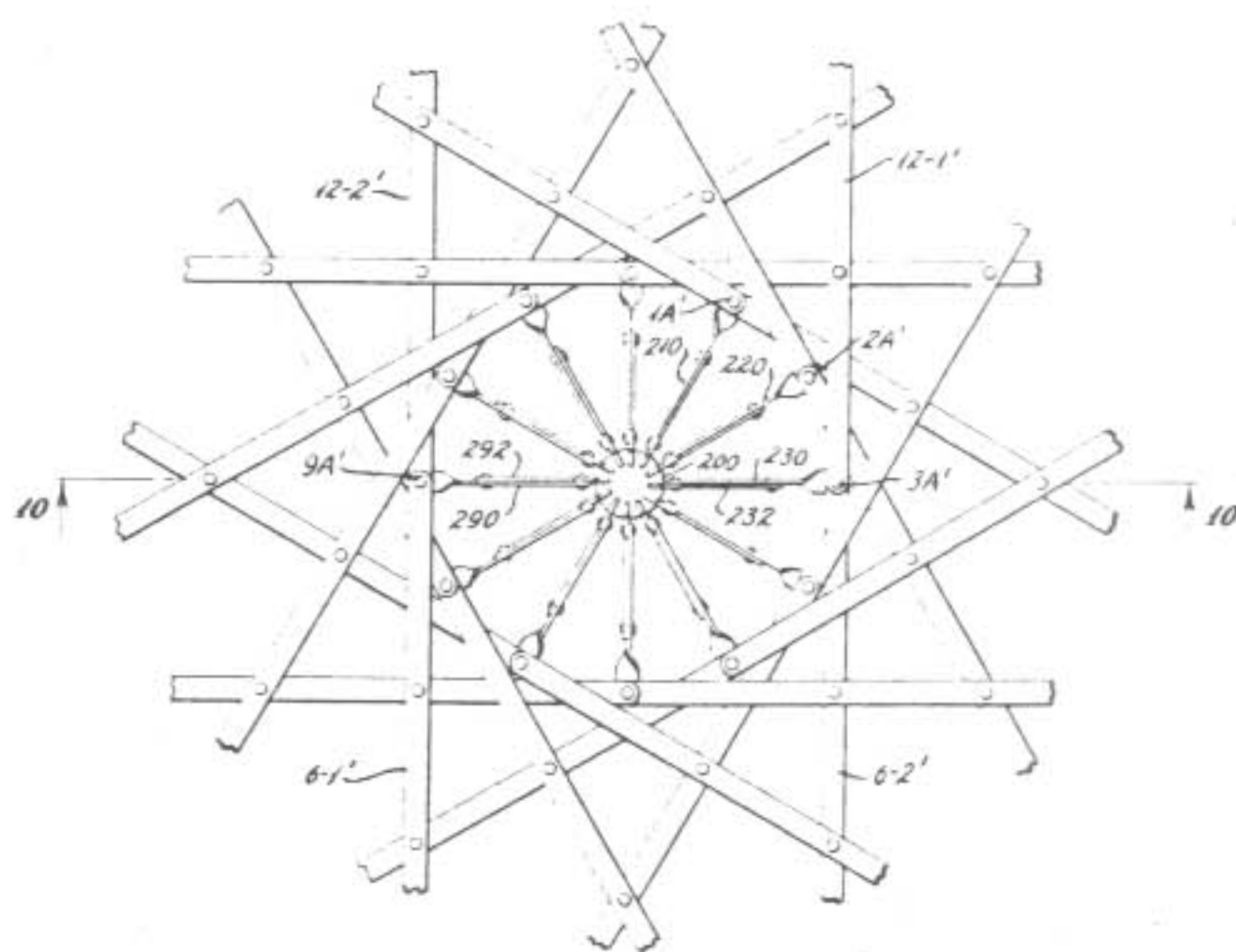

Figure 32

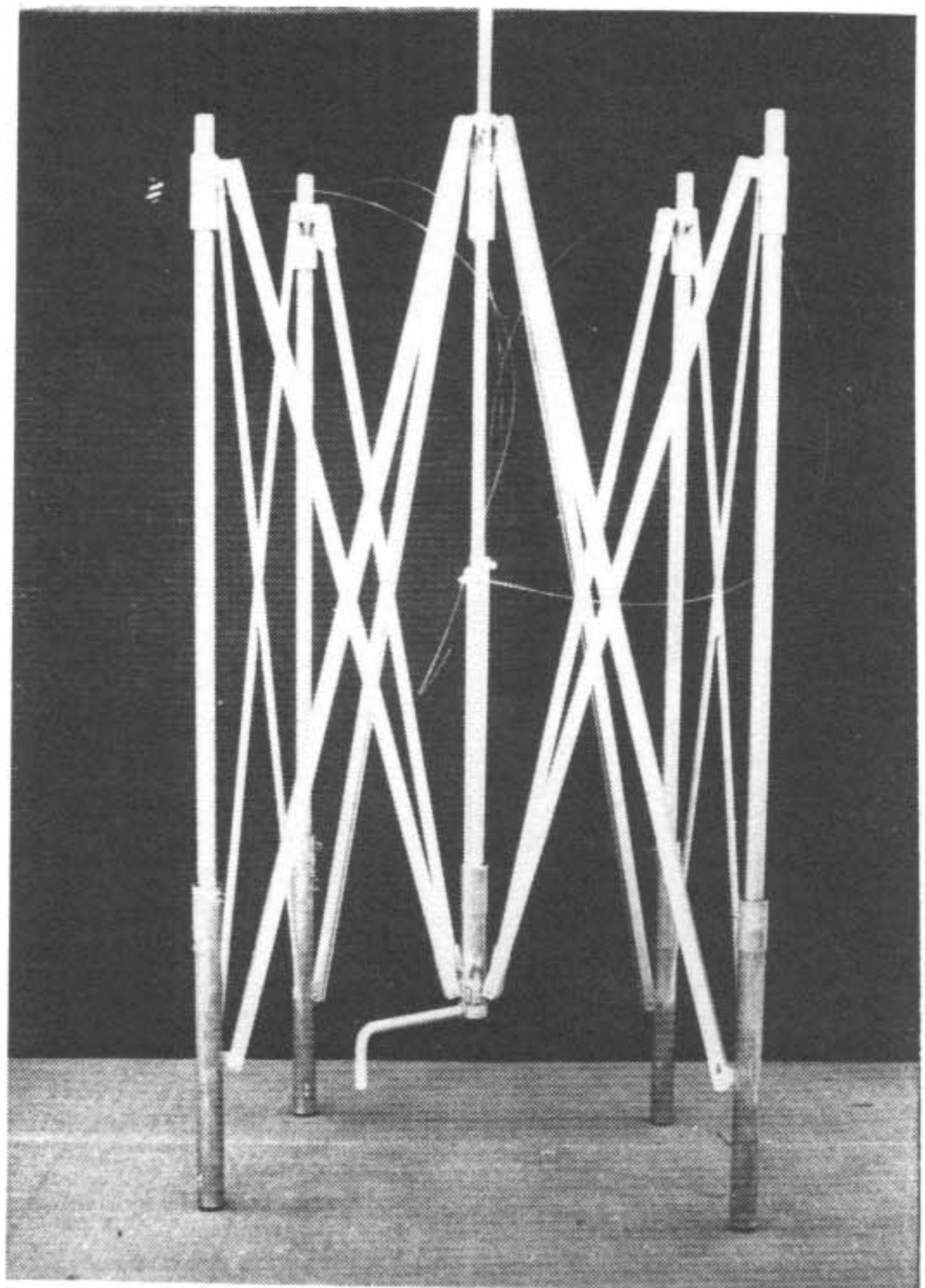
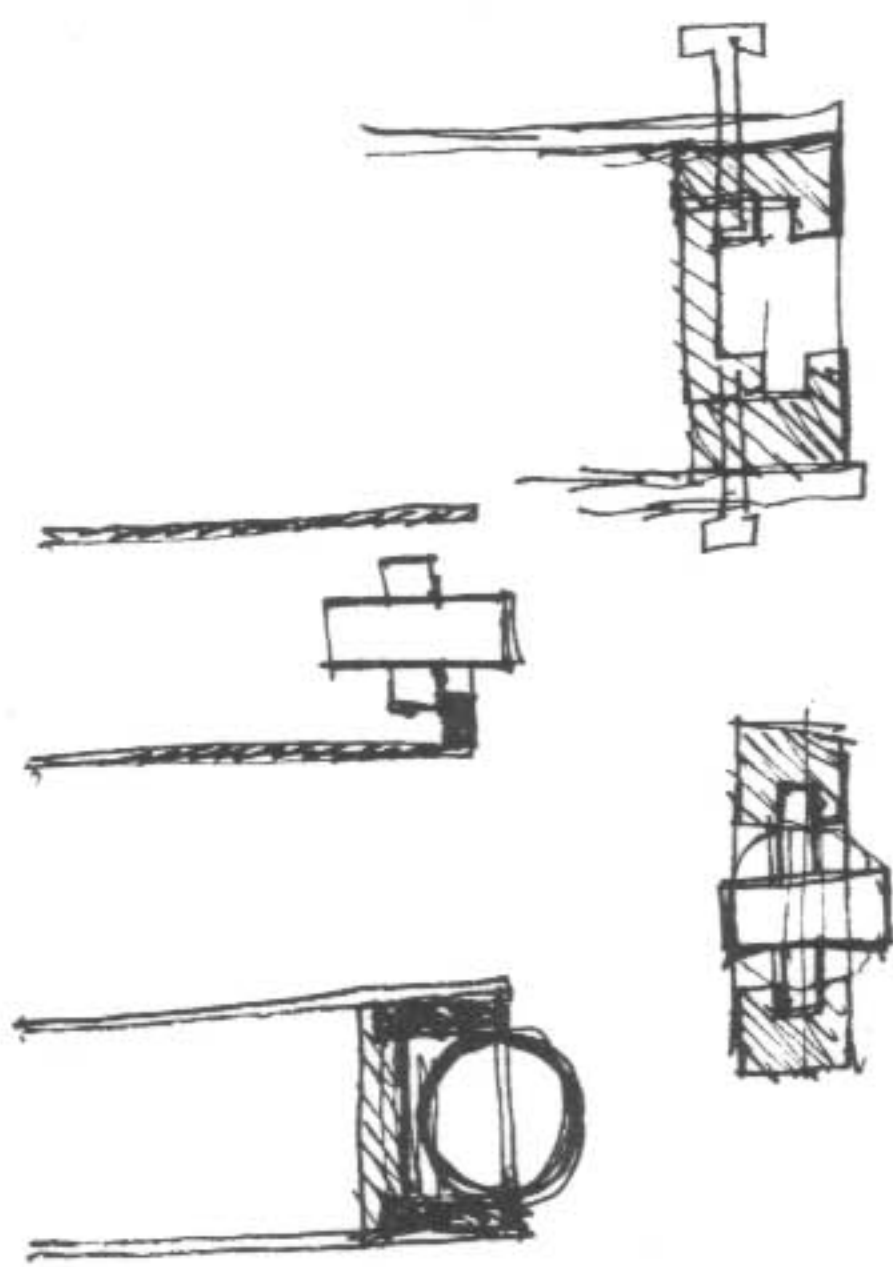
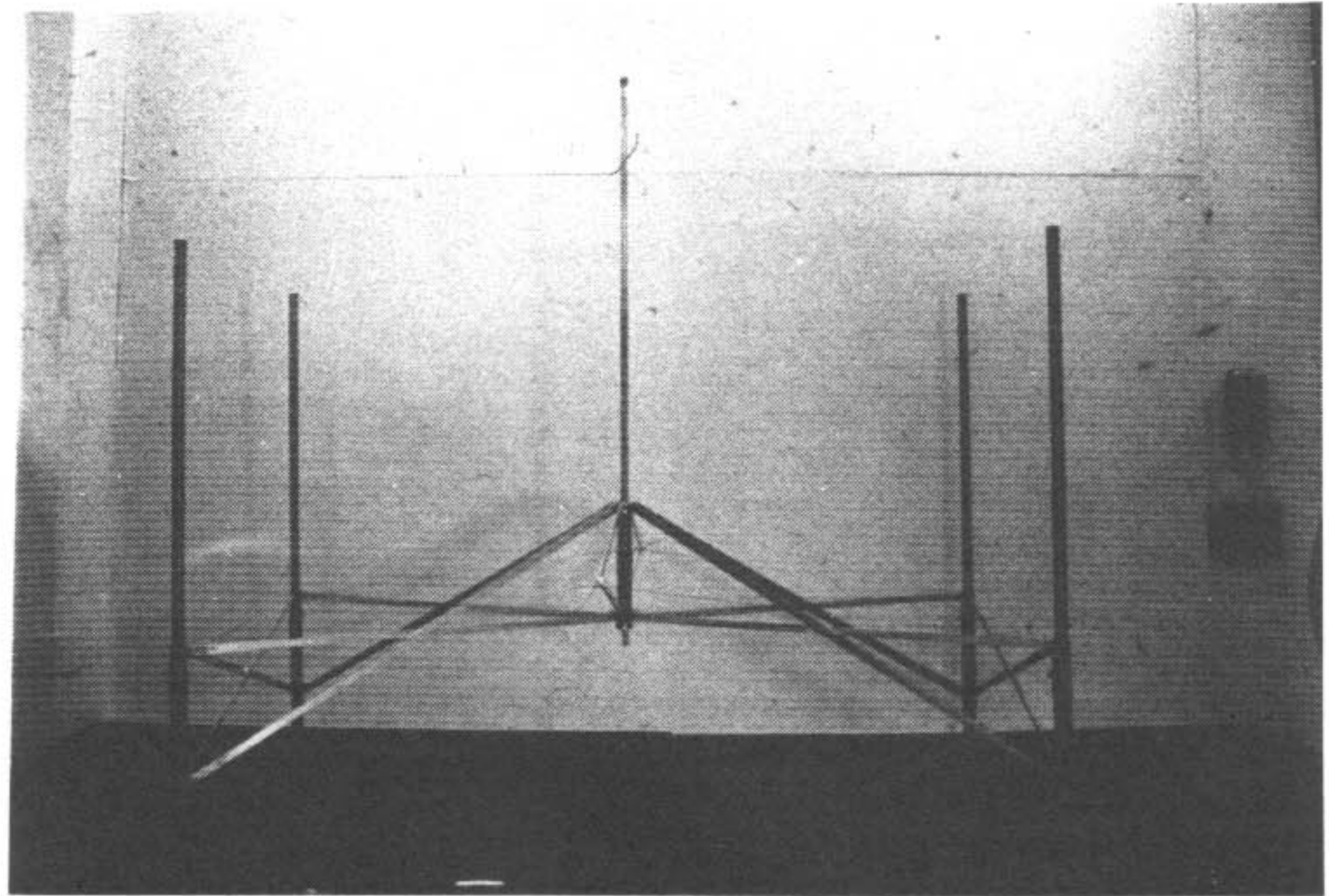

Figure 33

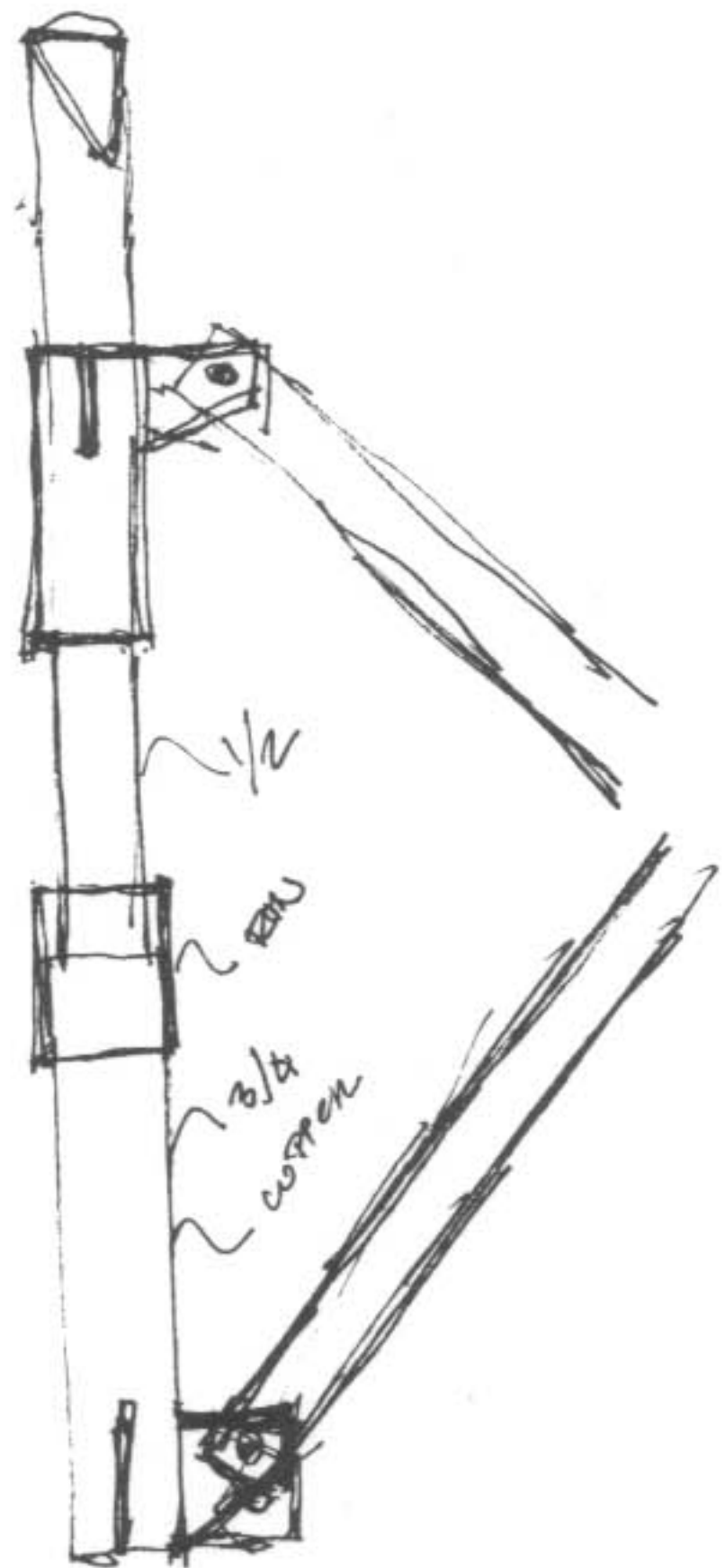
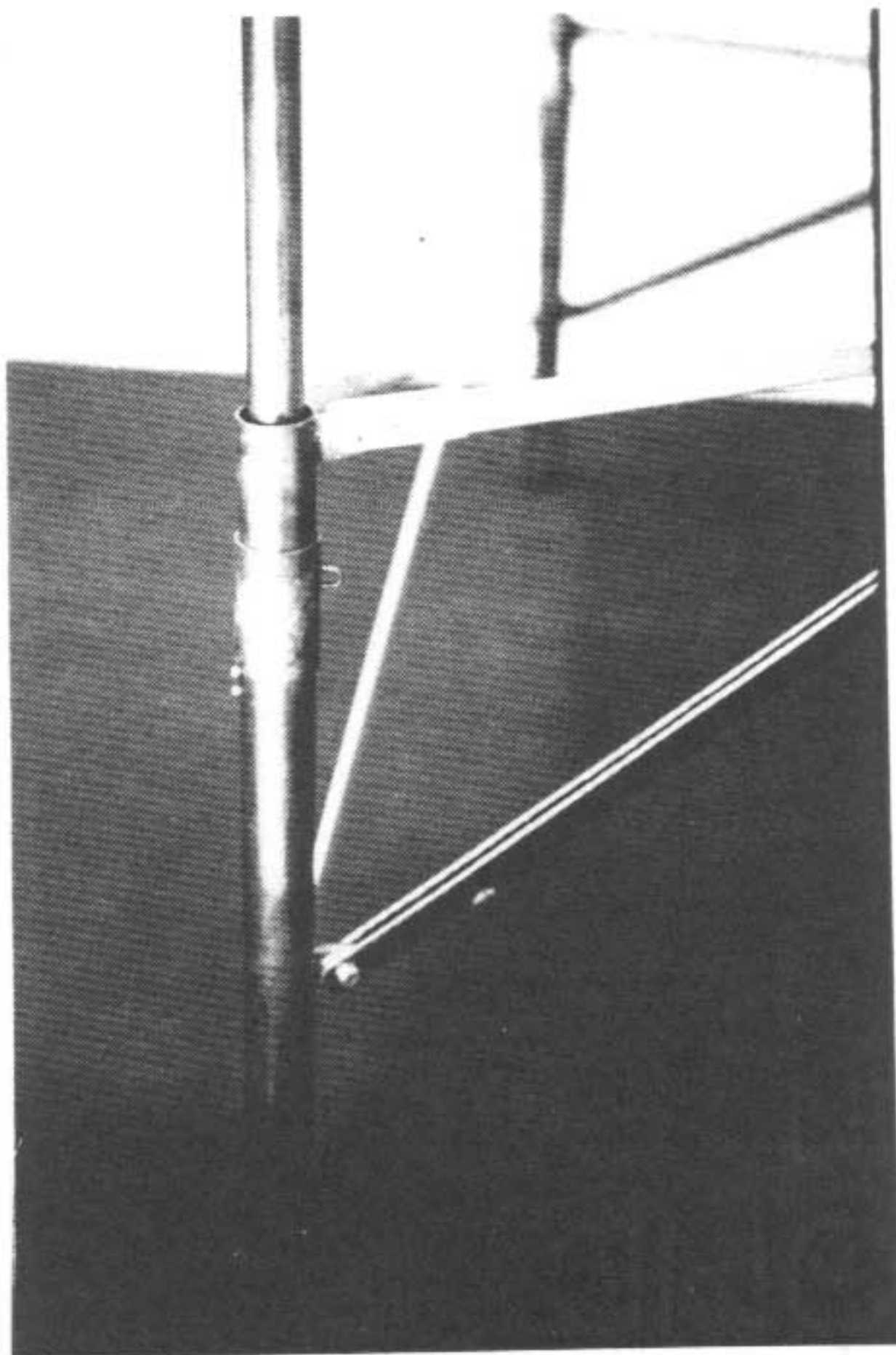
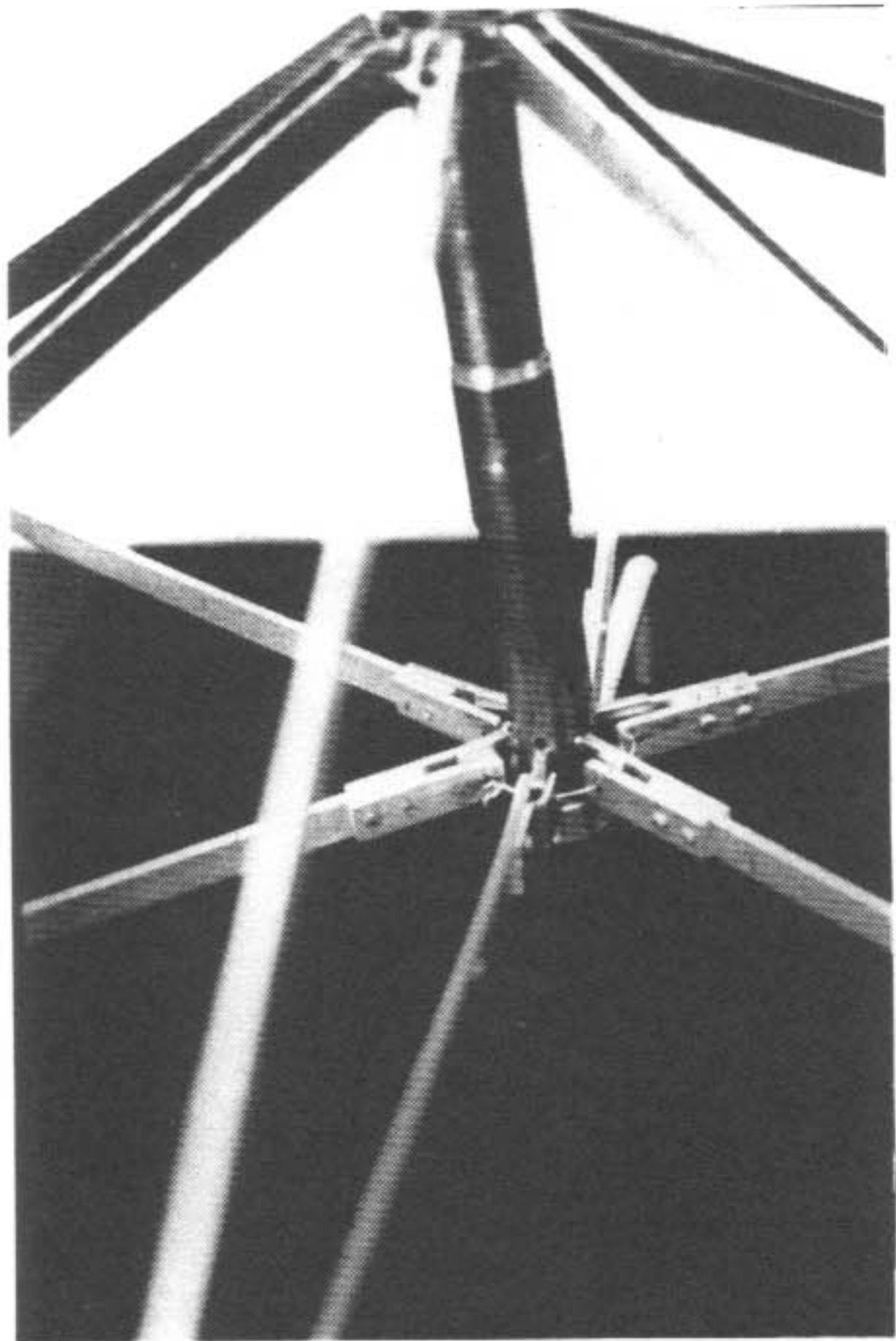
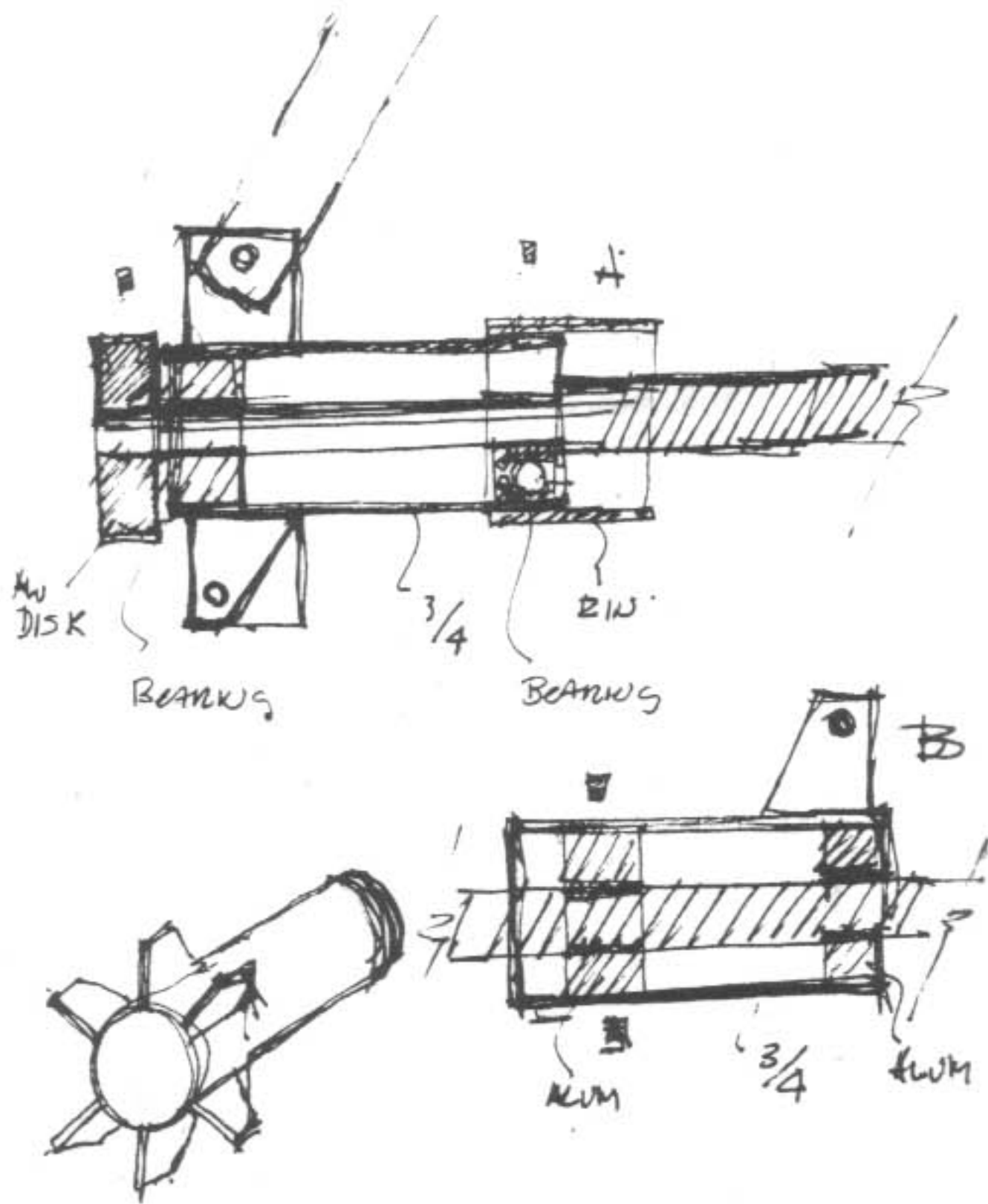

Figure 34

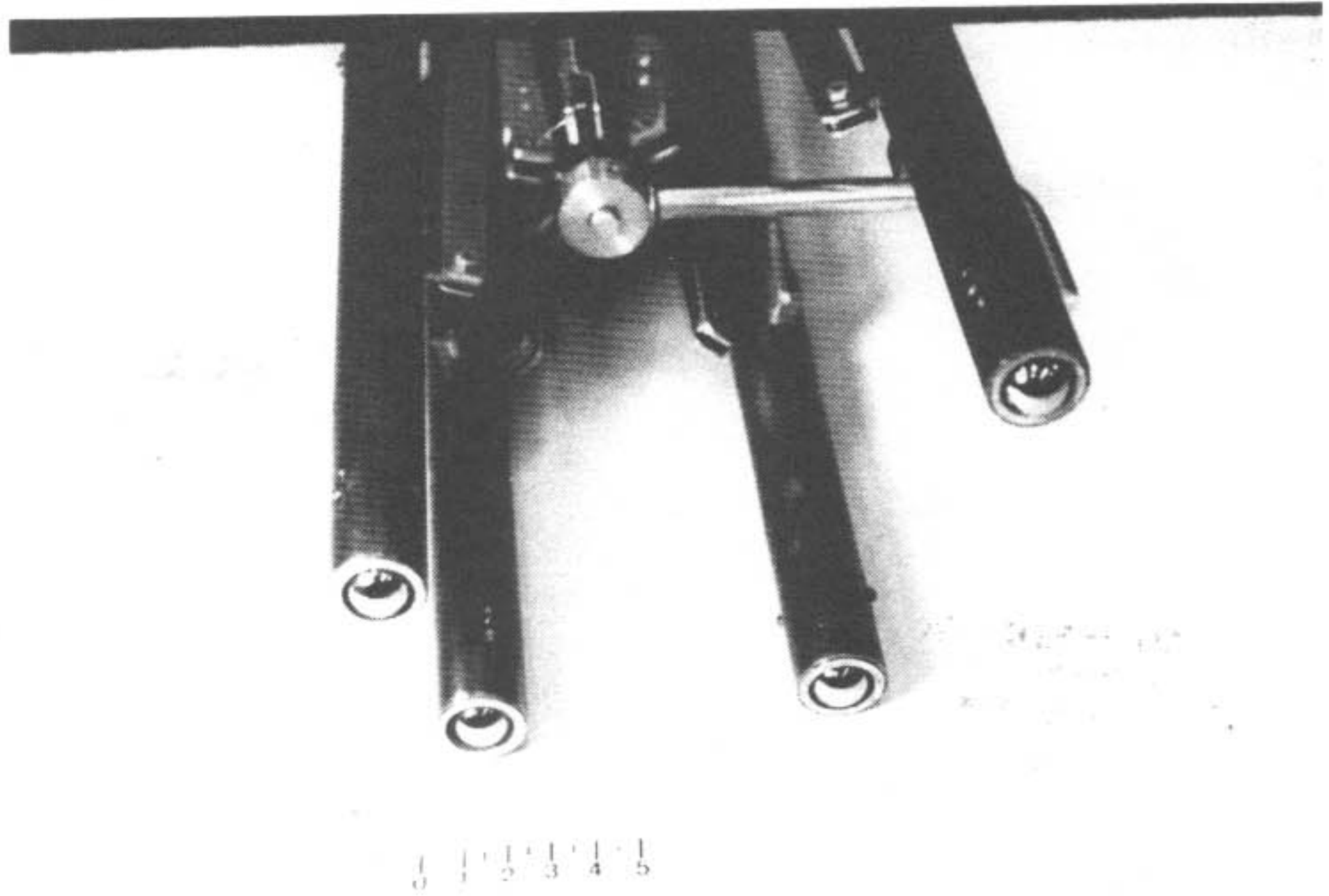

Figure 35

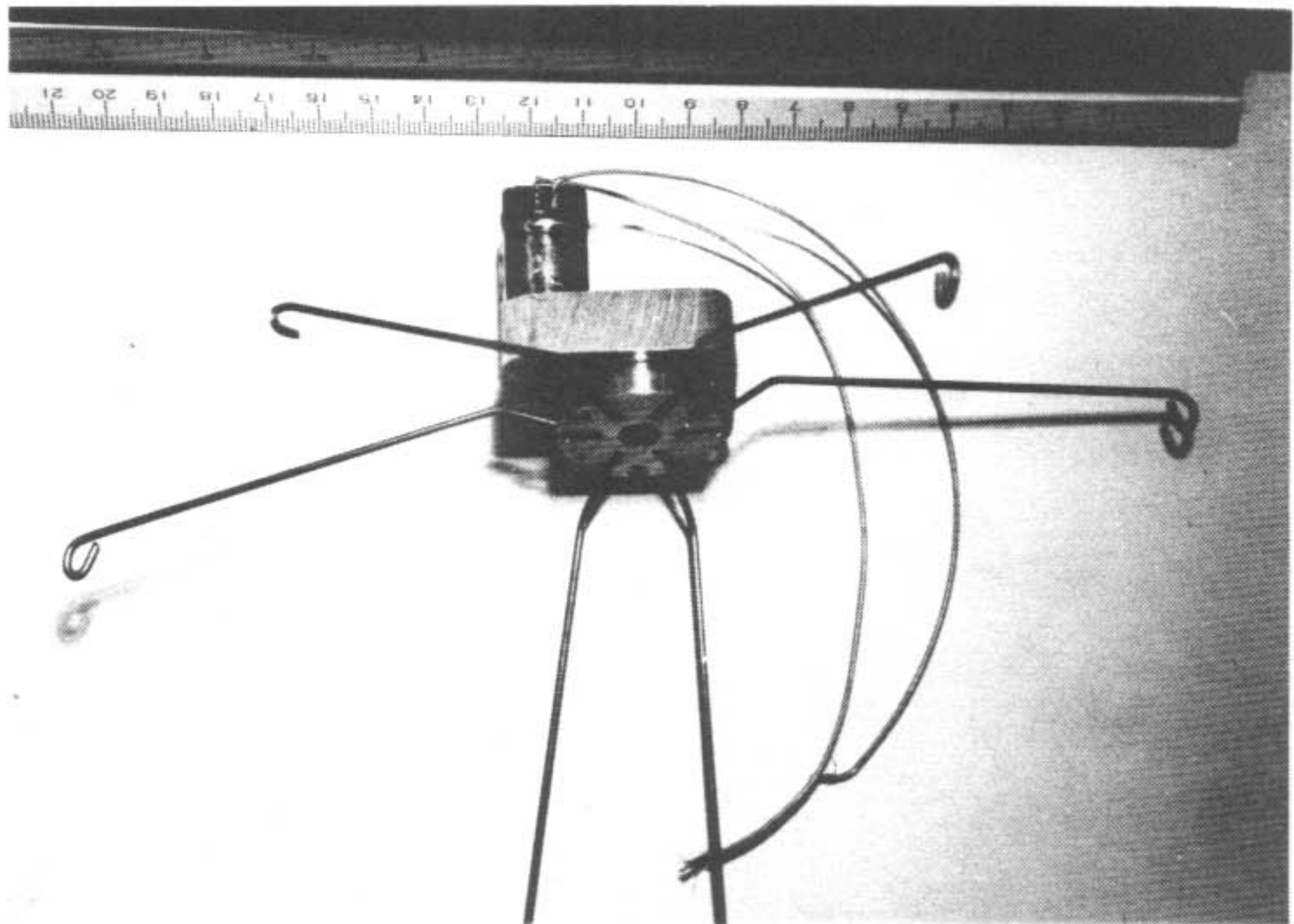

Figure 36

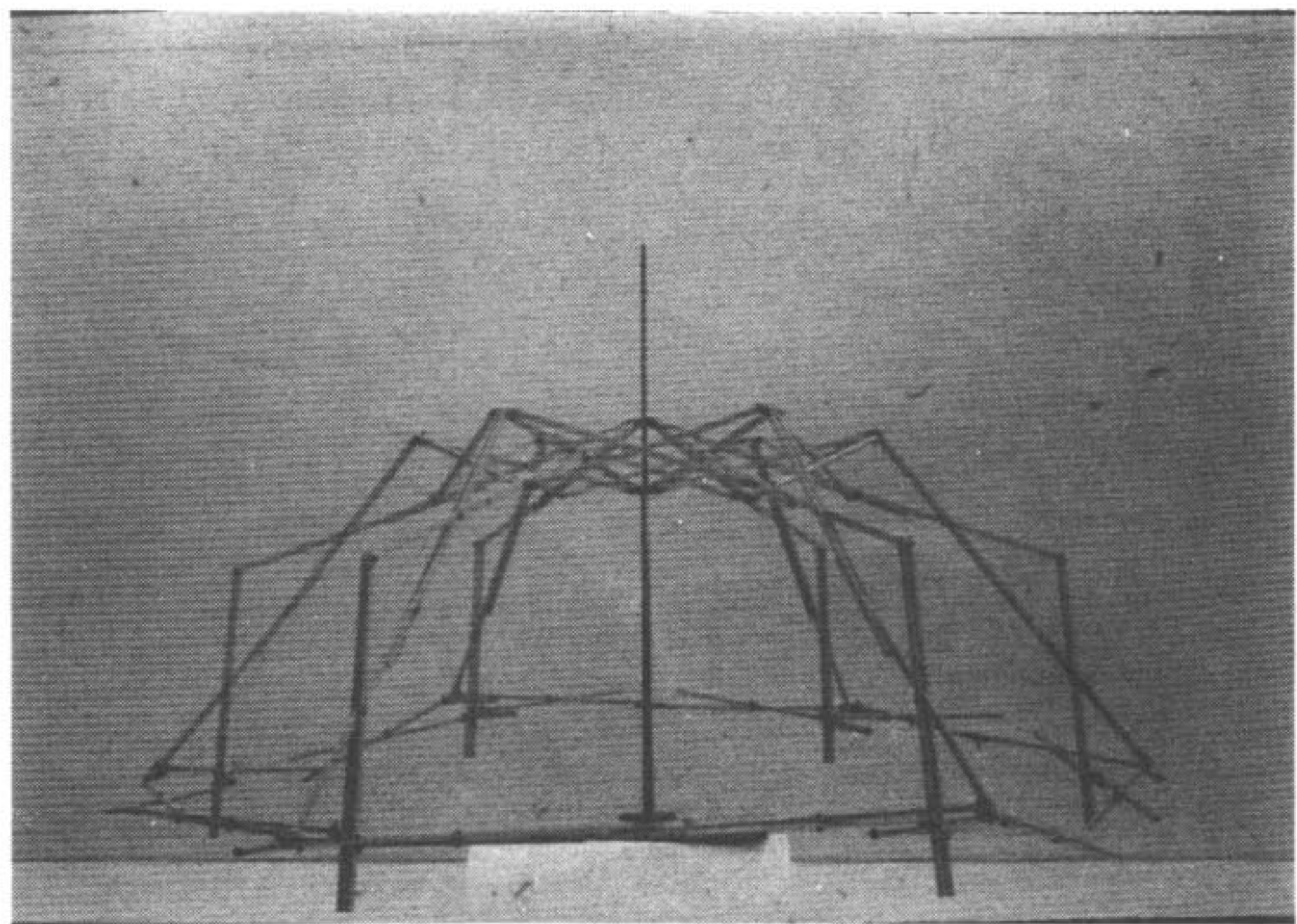
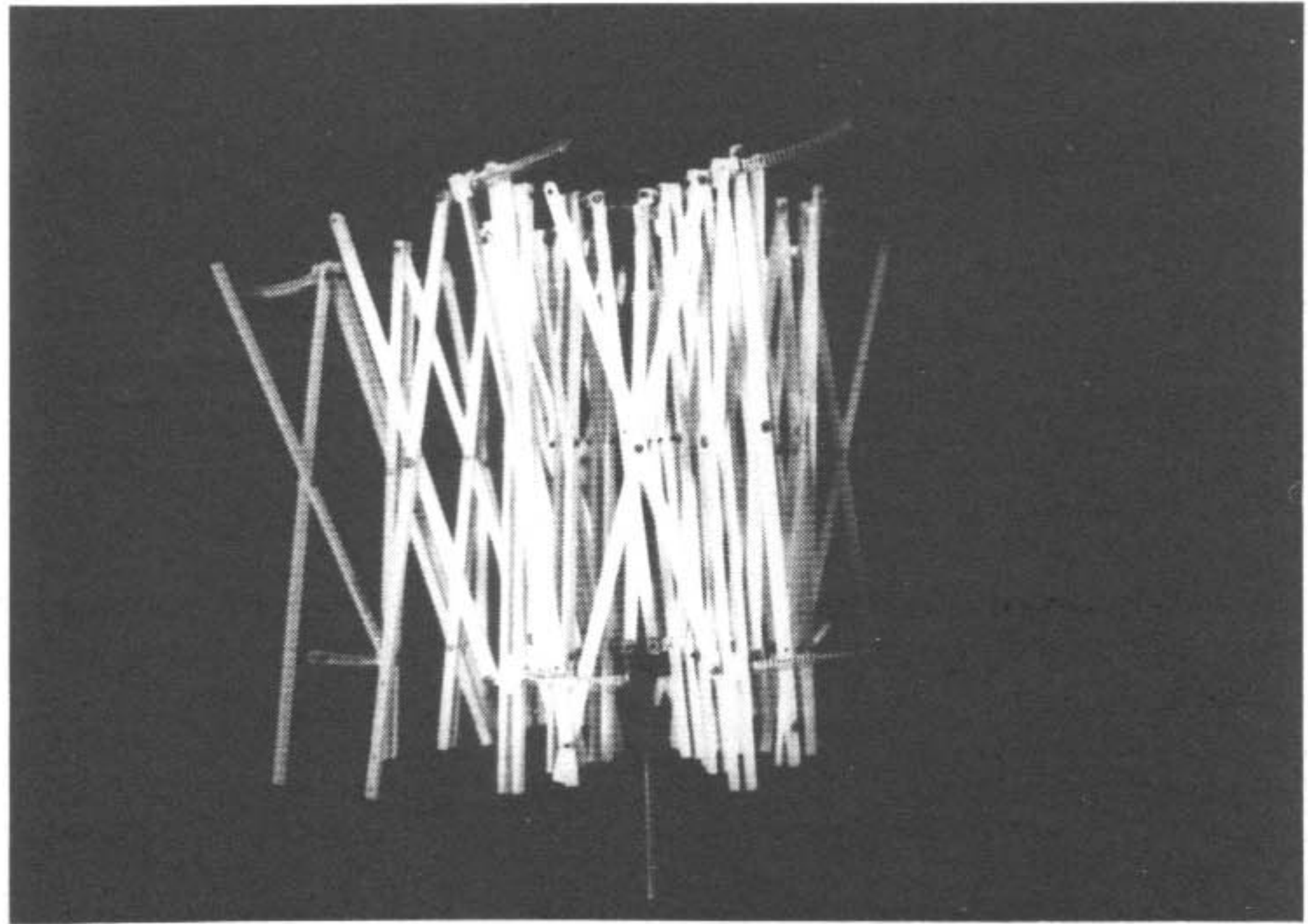

Figure 37

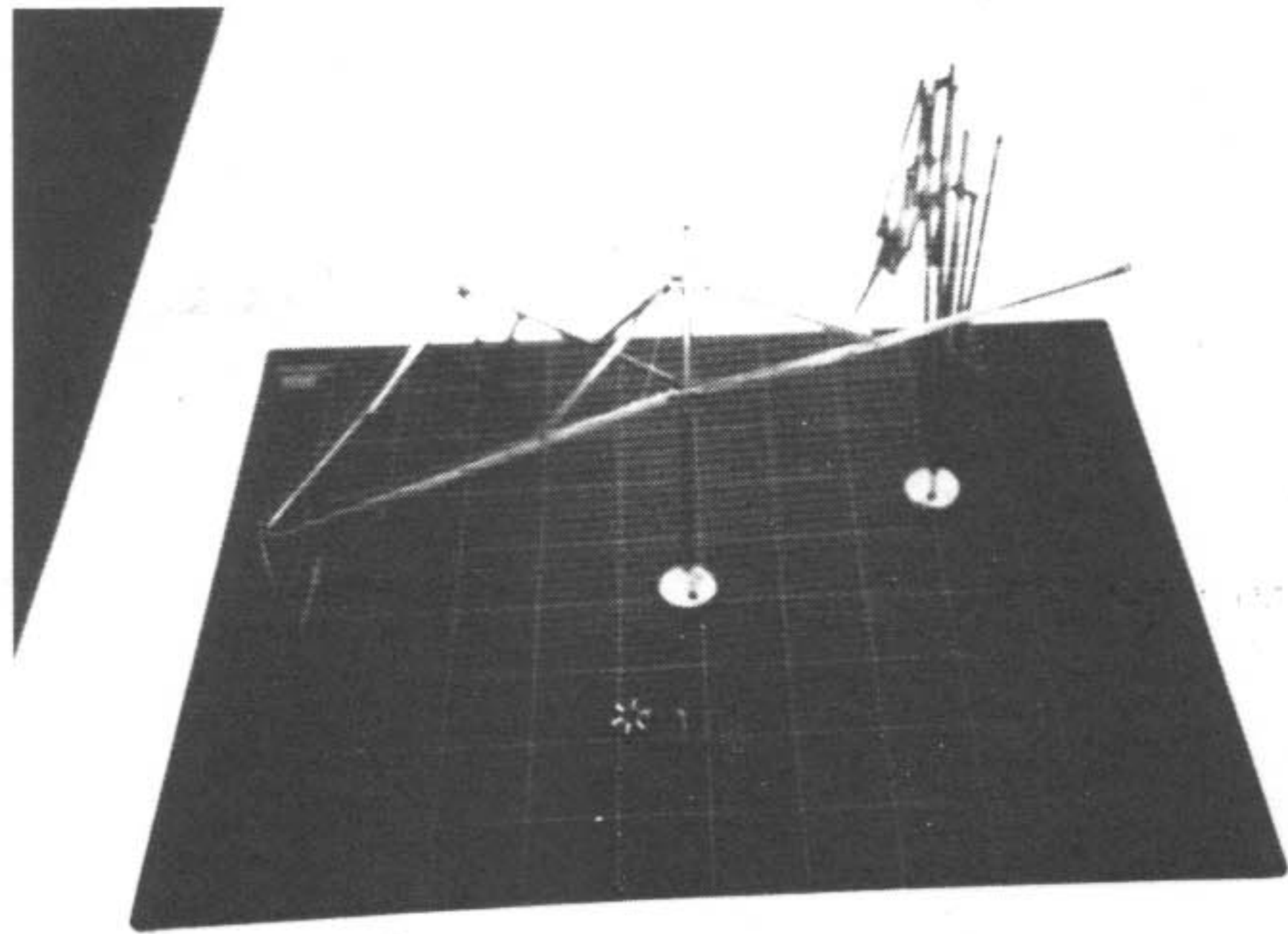

Figure 38

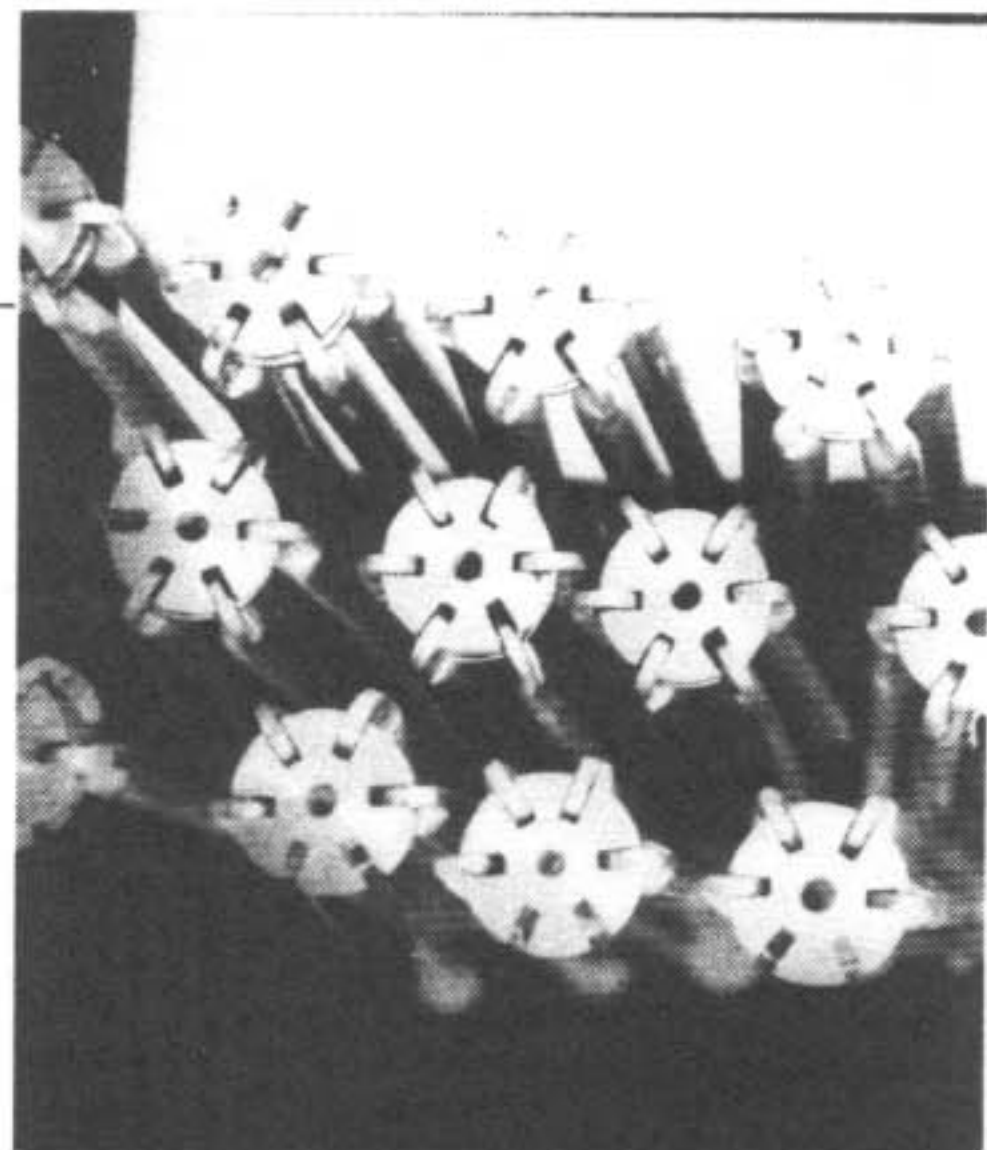
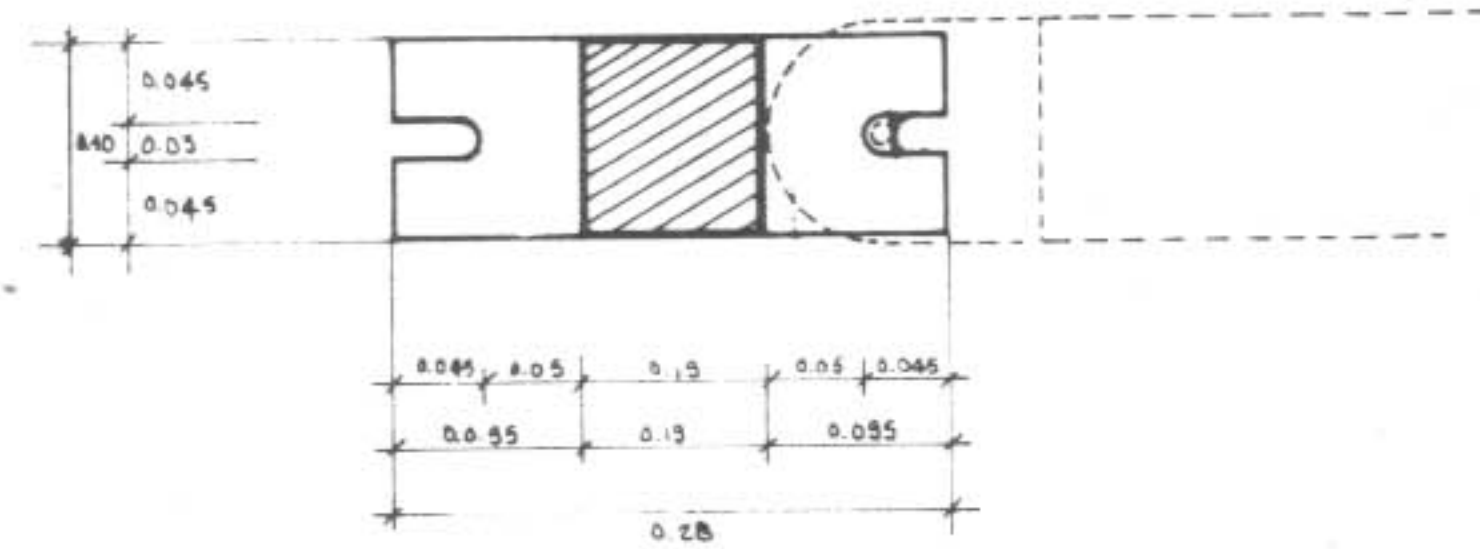
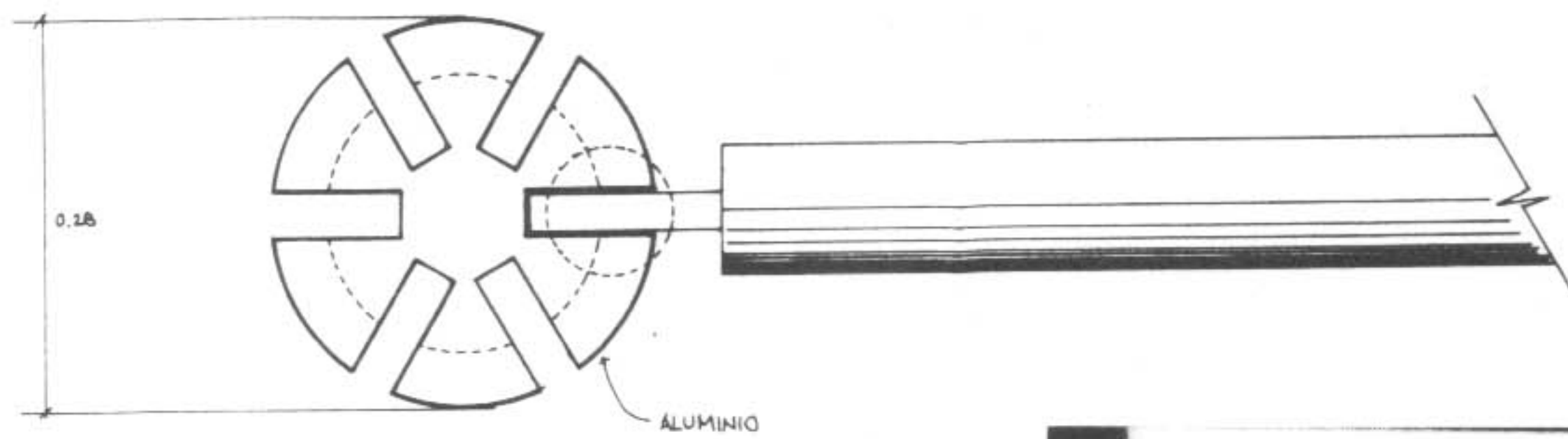

Figure 39

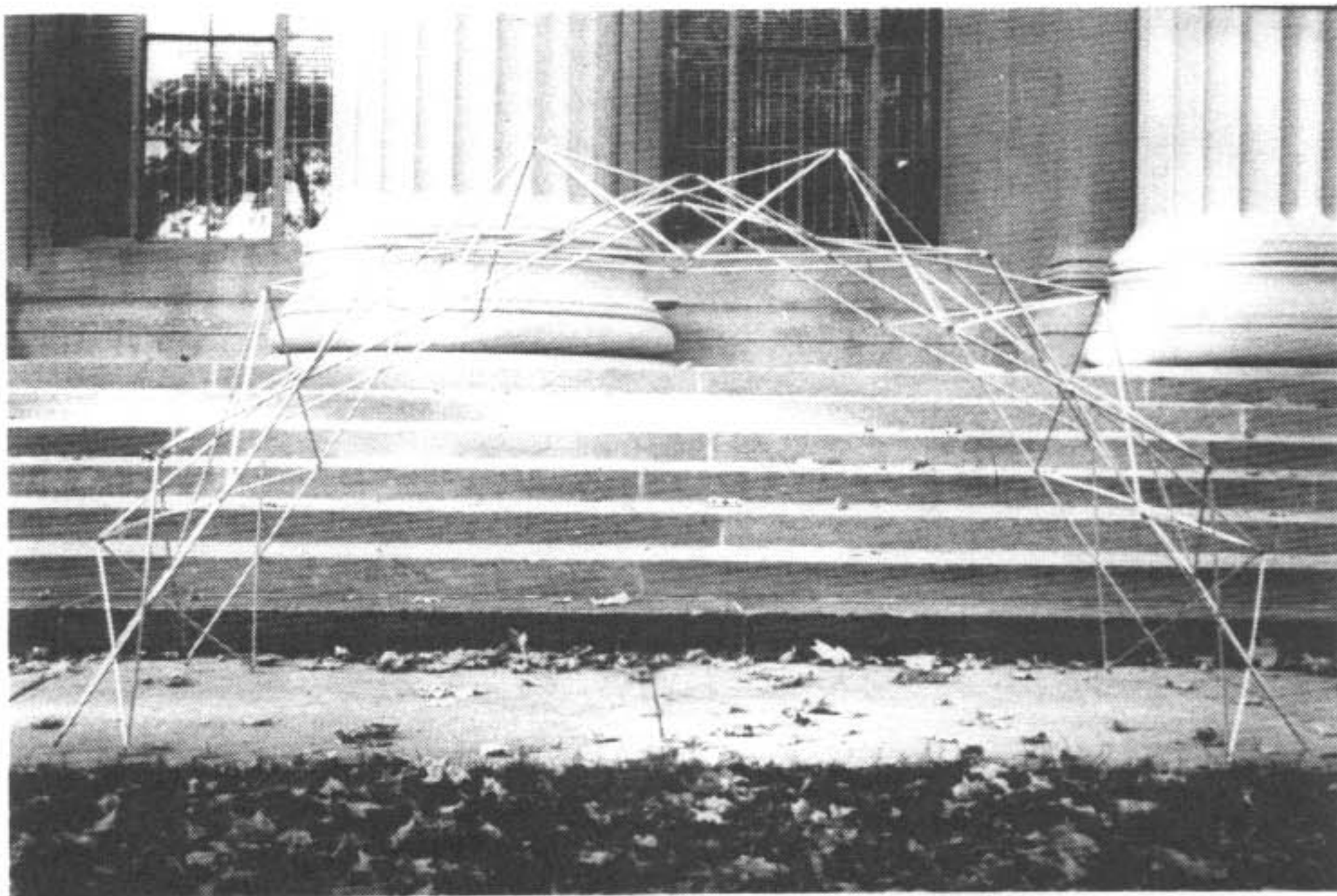
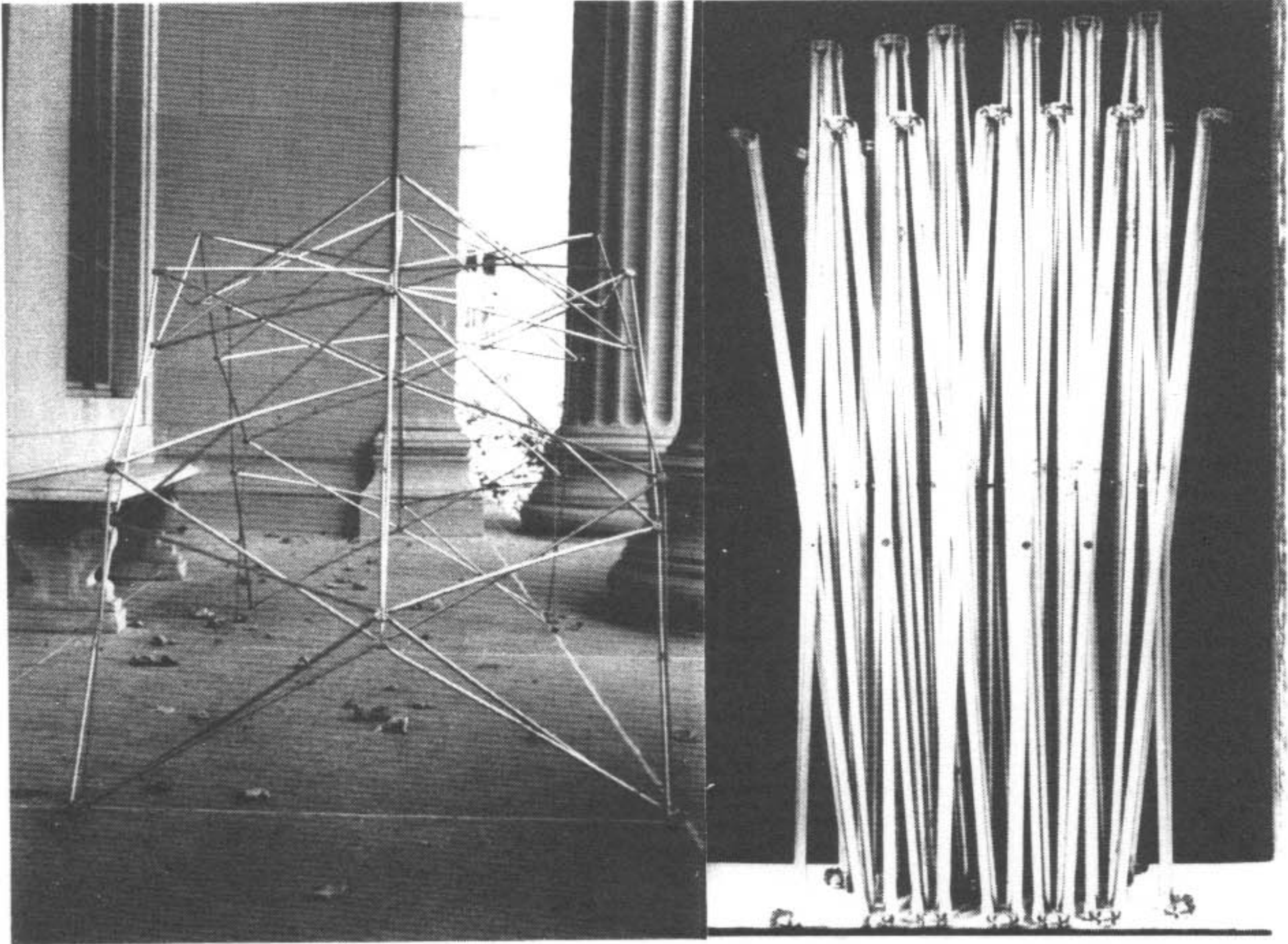

Figure 40

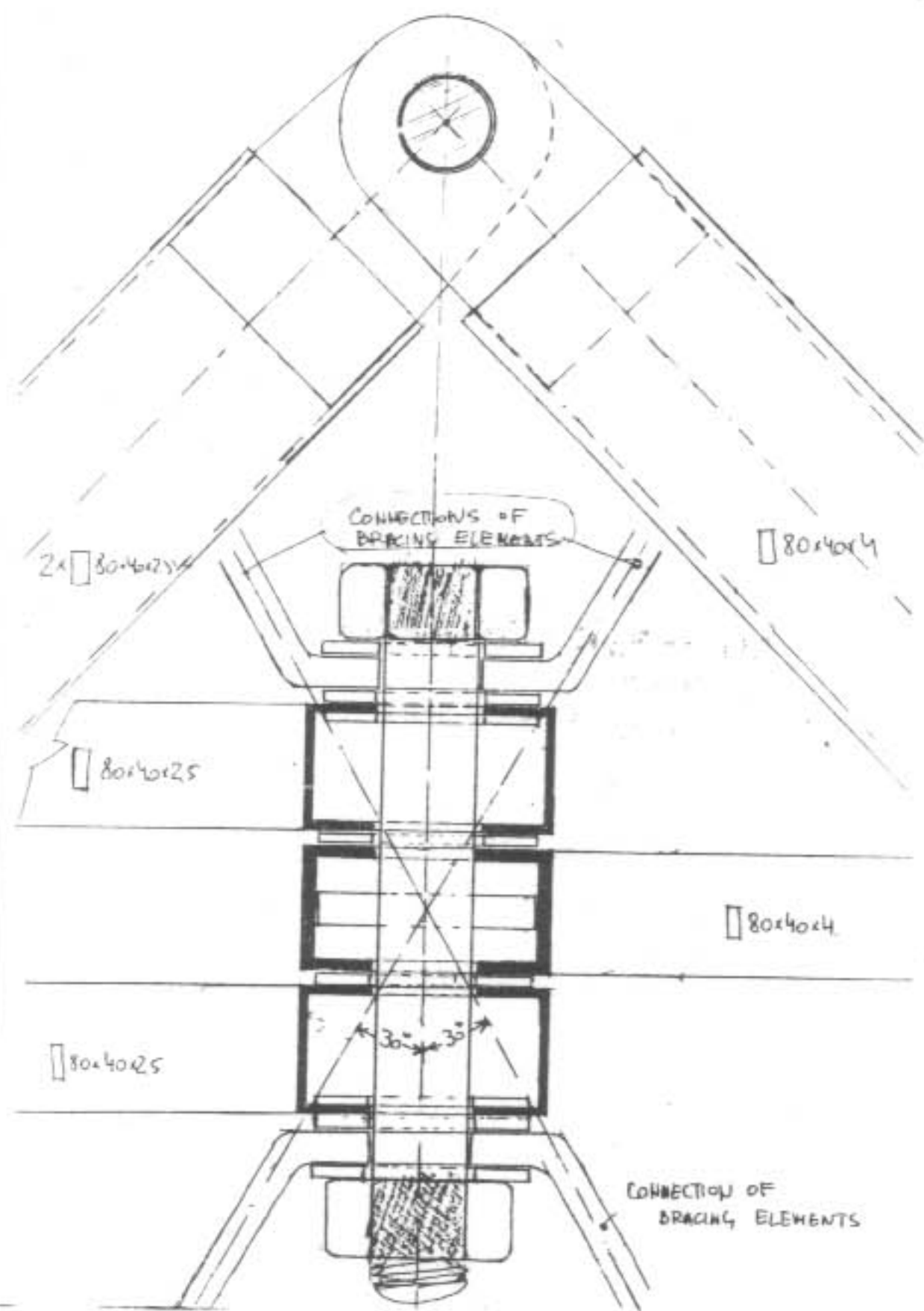
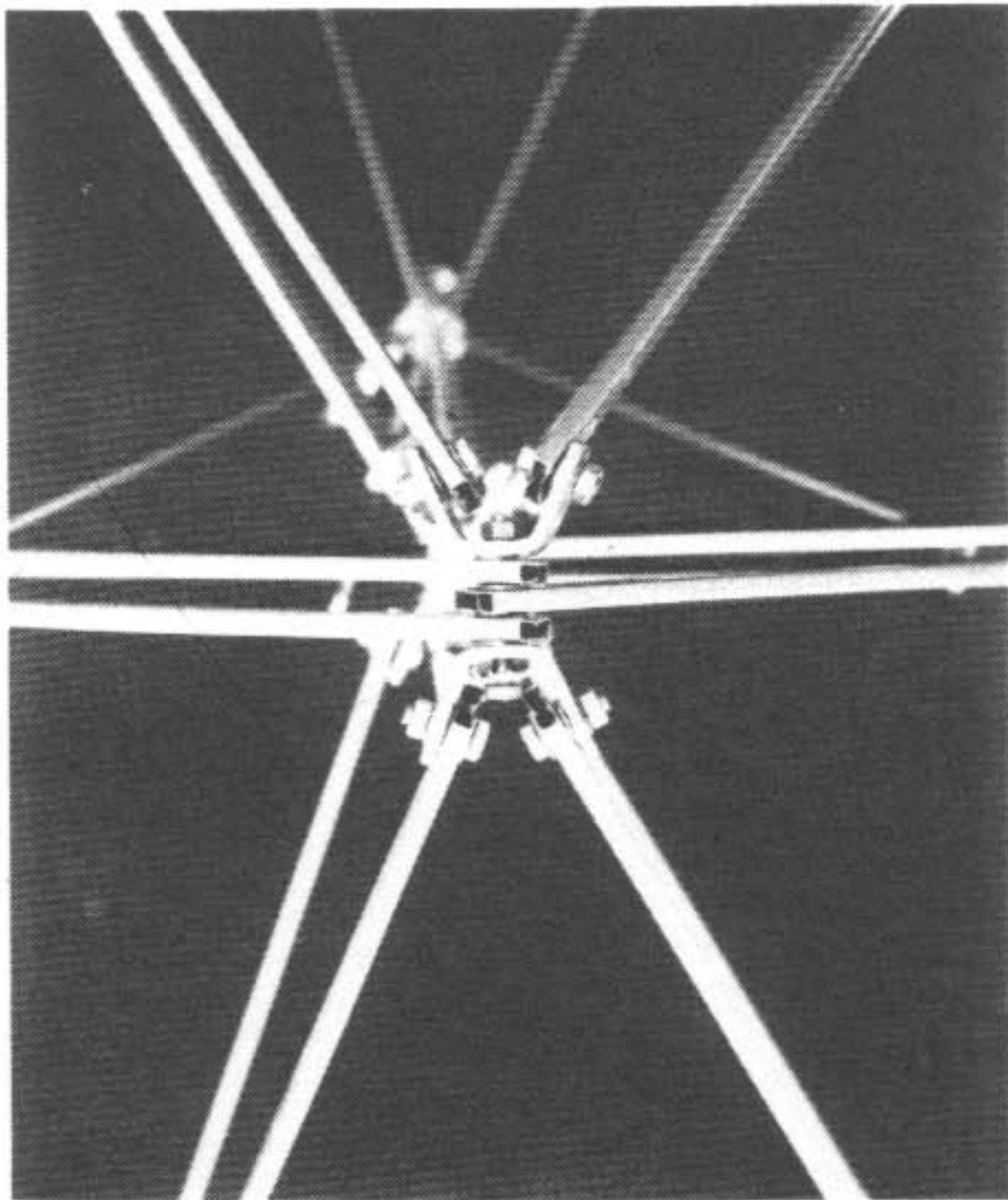

Figure 41

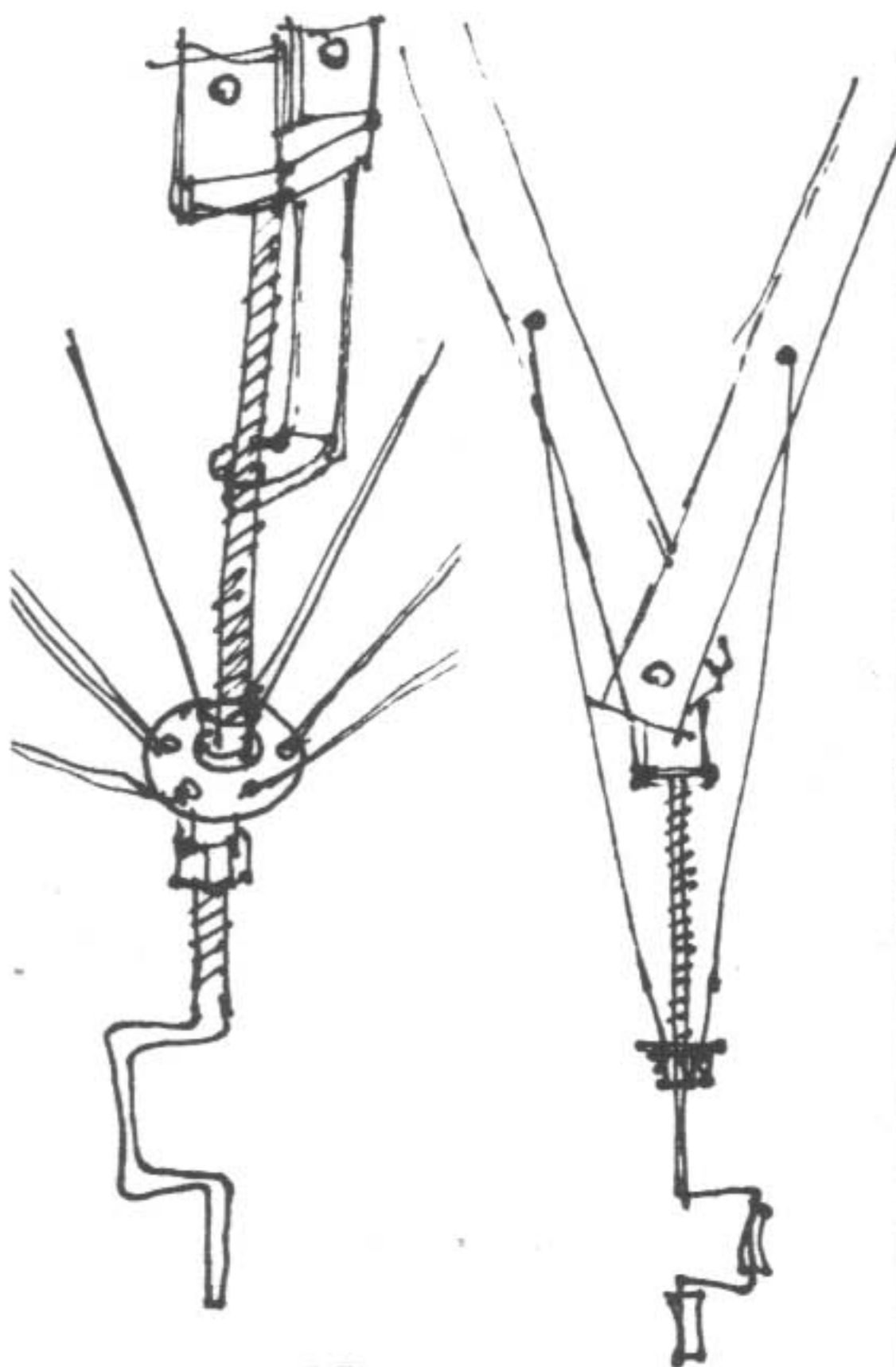
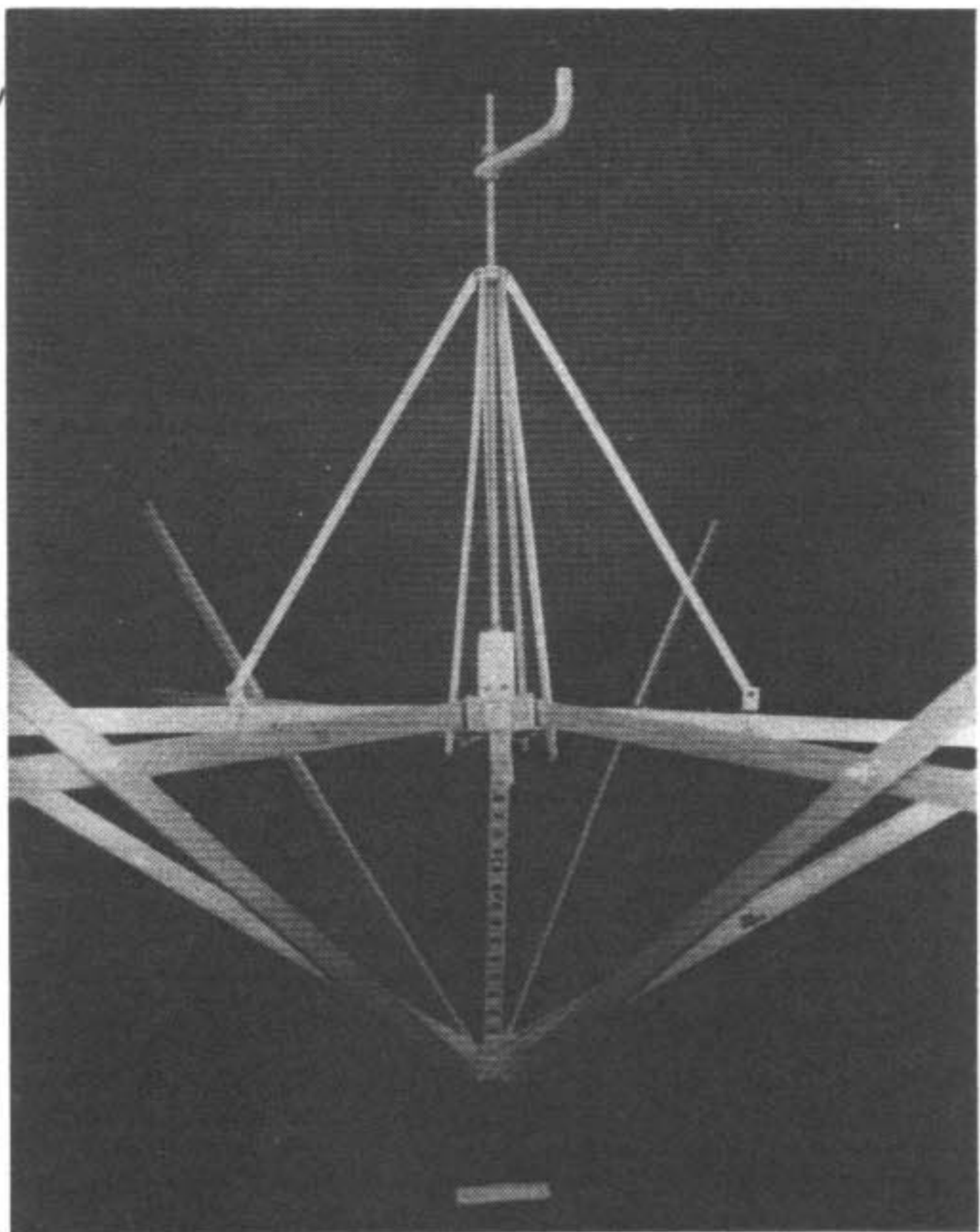

Figure 42



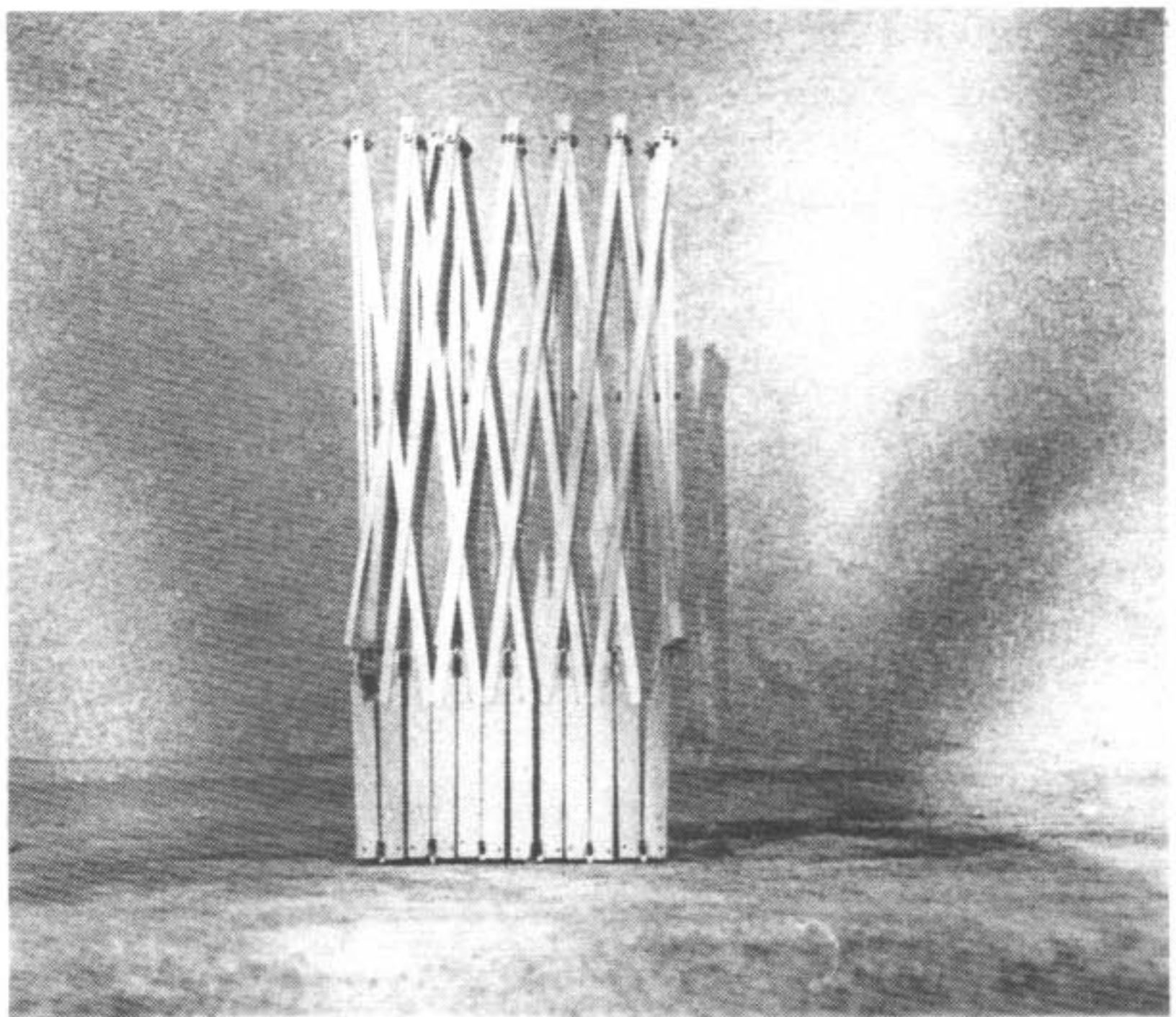
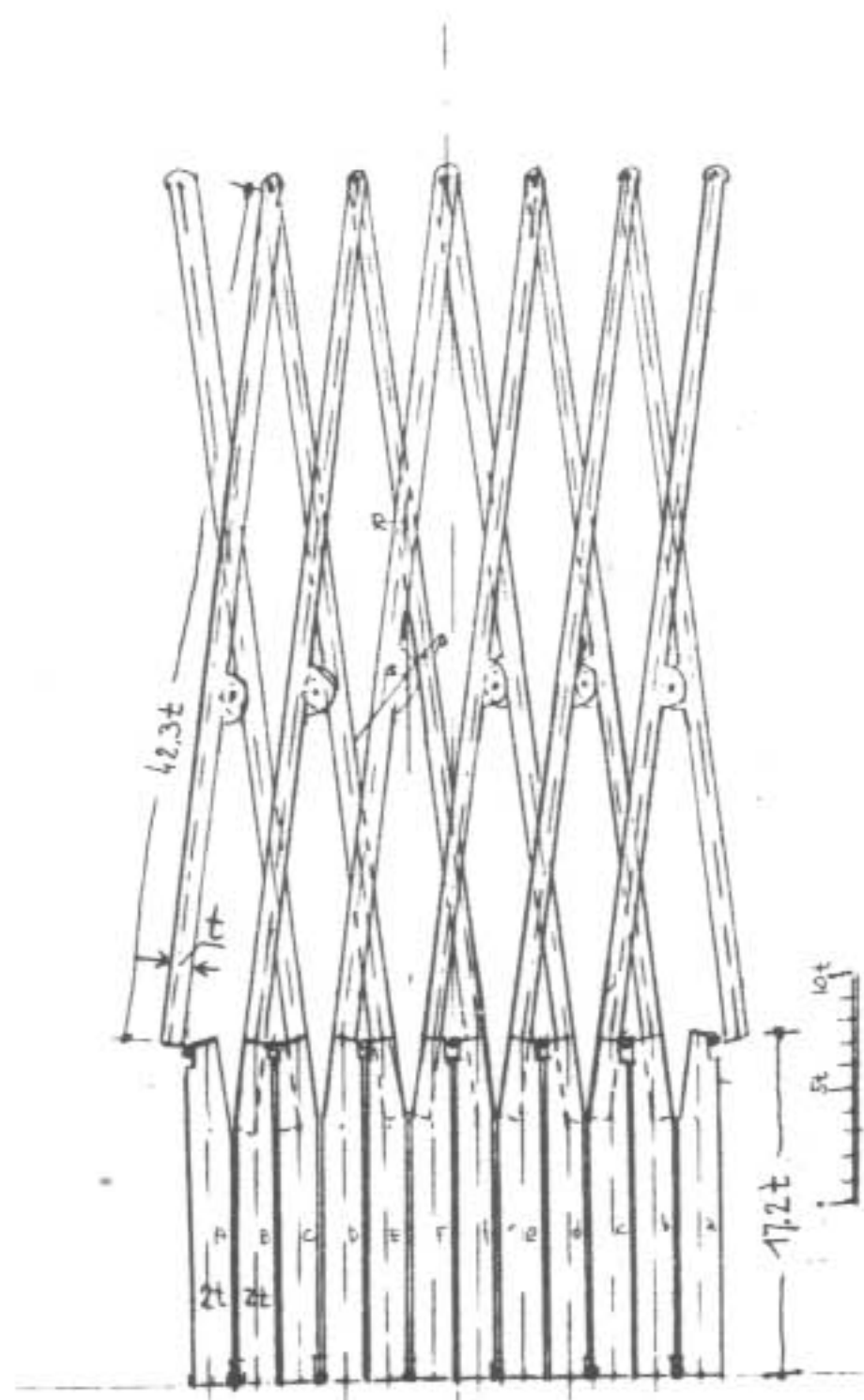
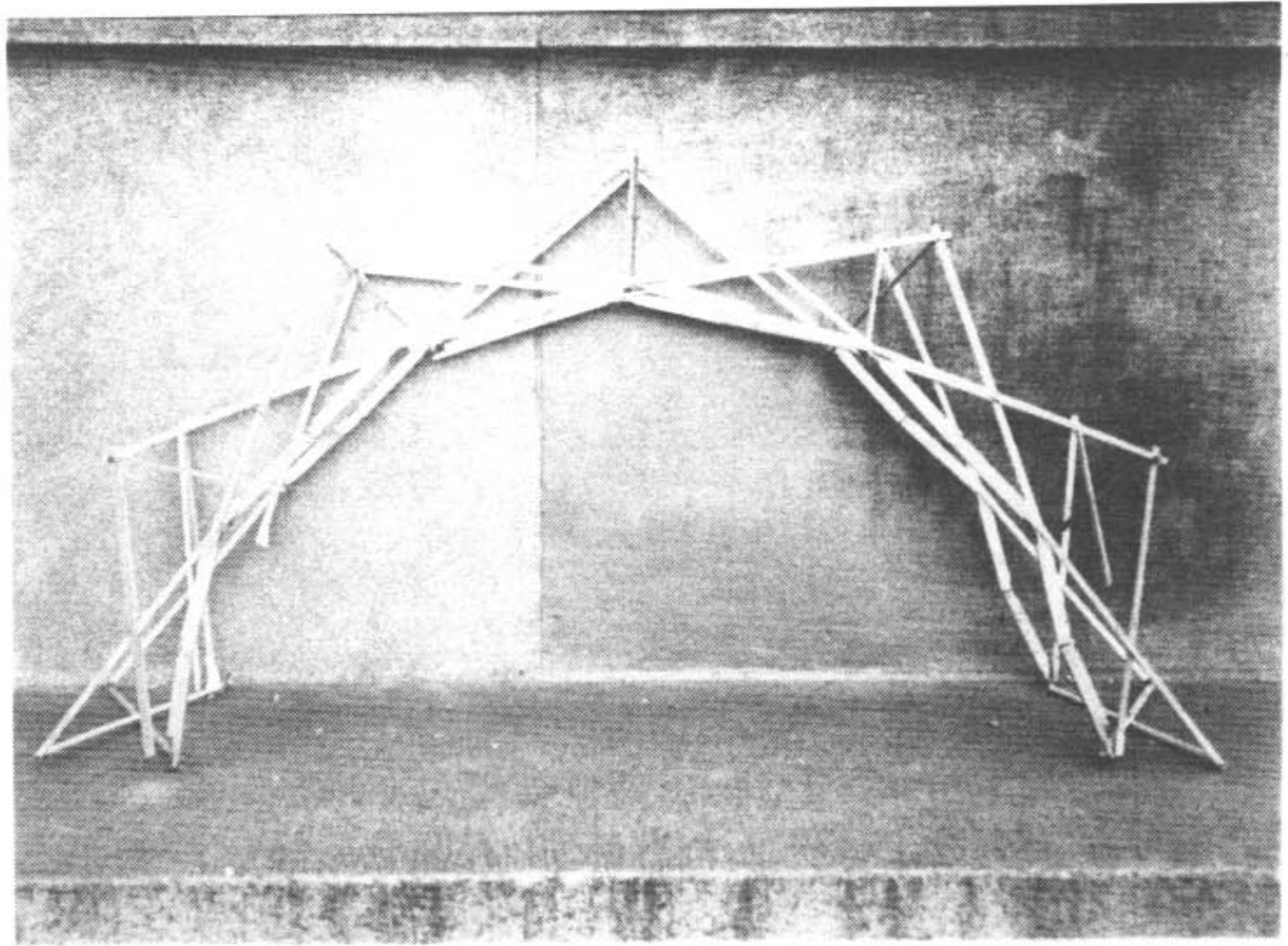

Figure 43

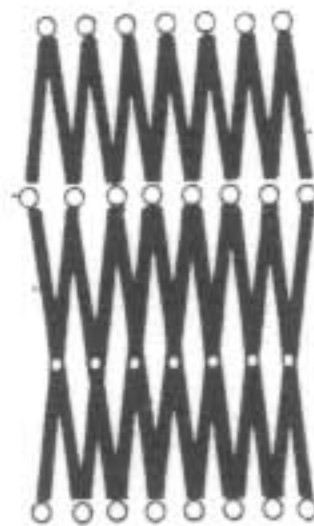
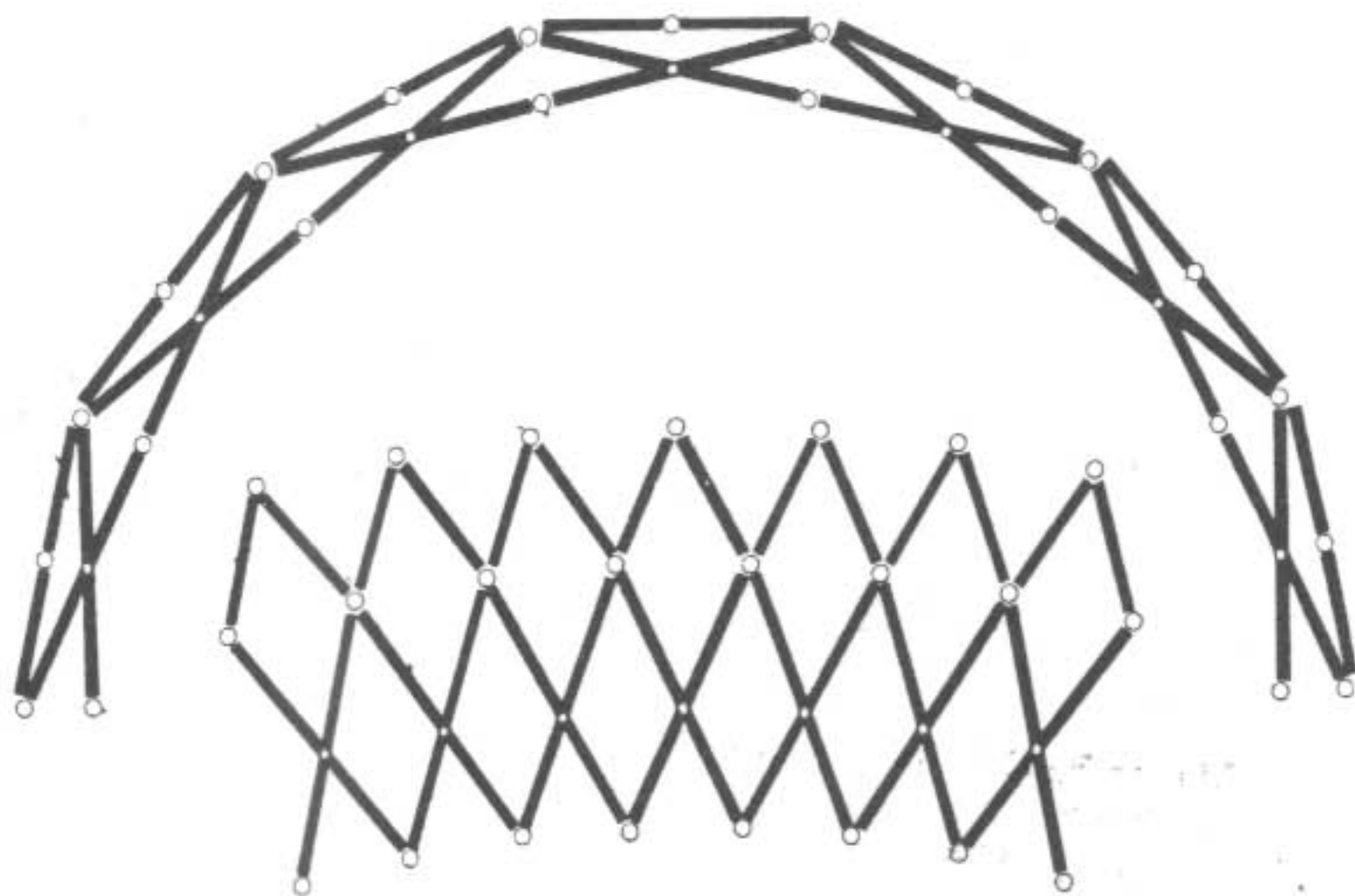

Figure 44

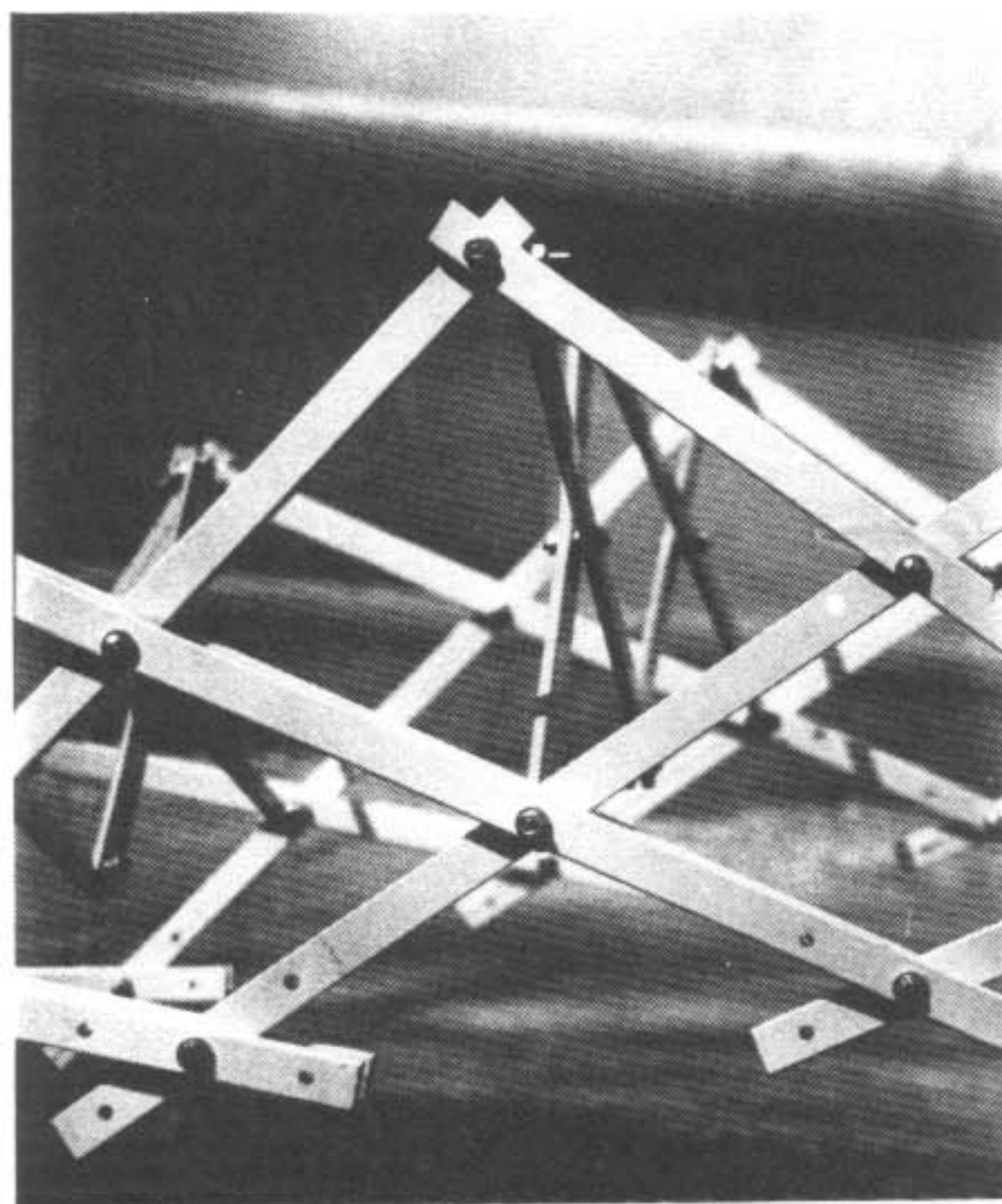

Figure 45

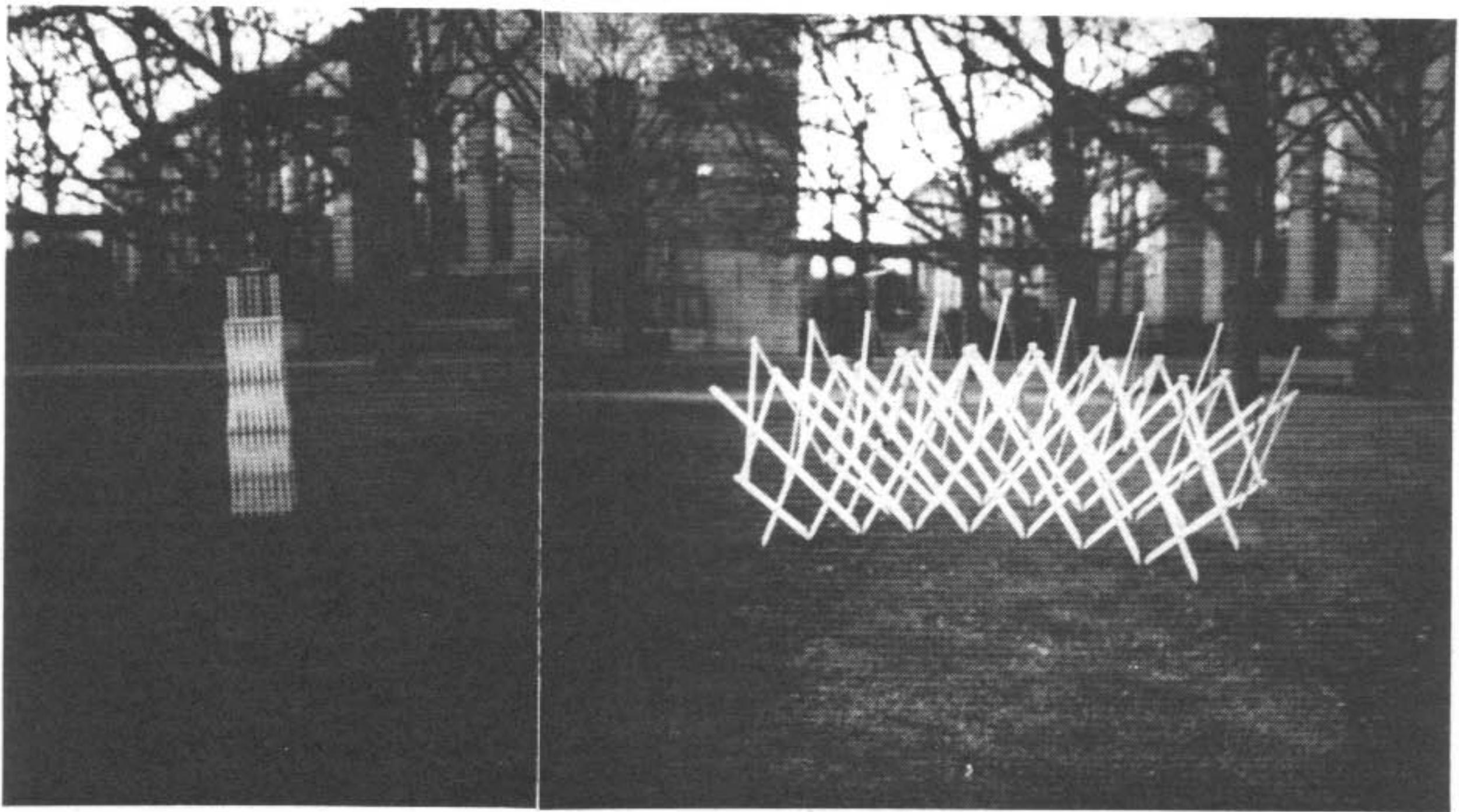
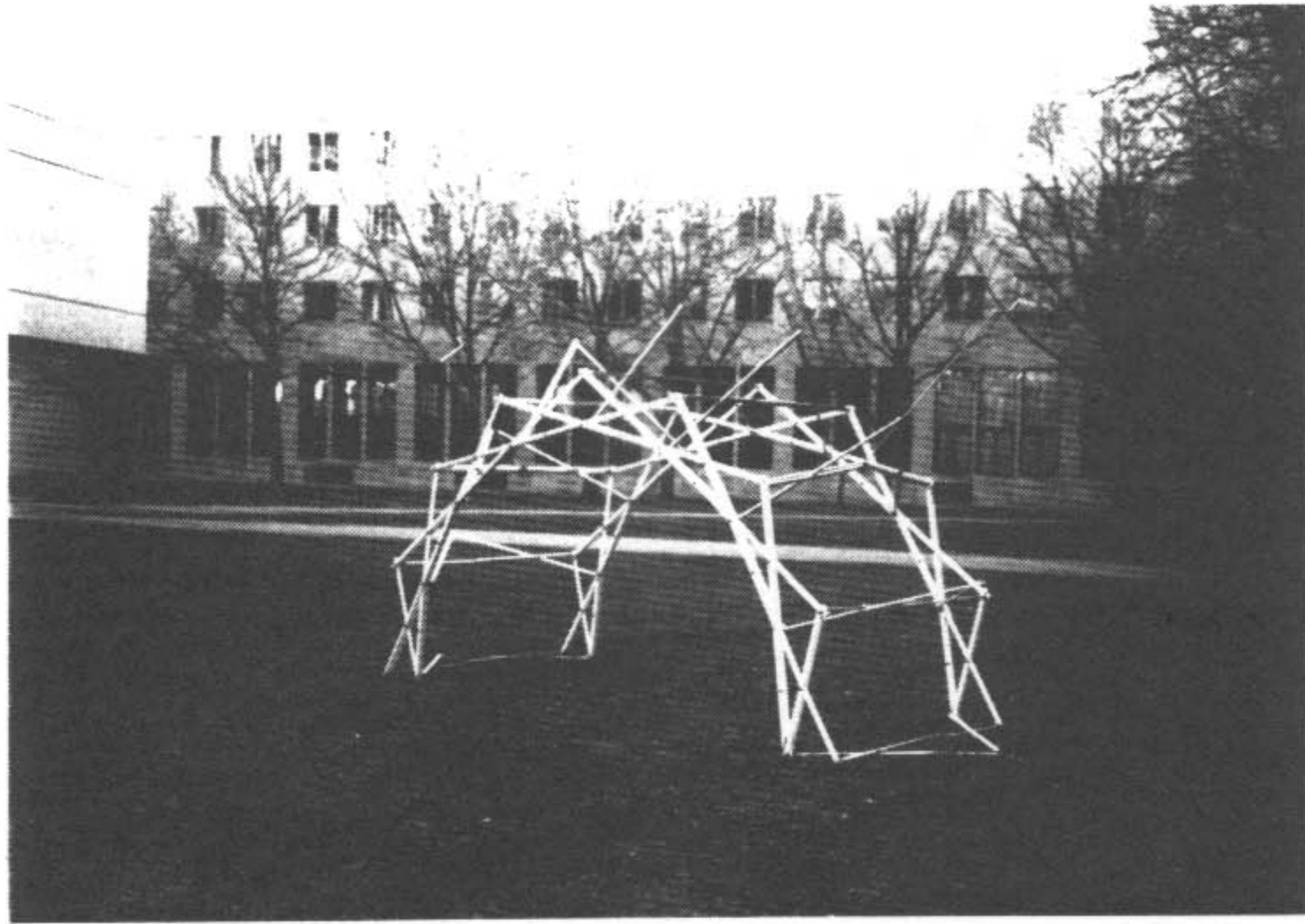

Figure 46

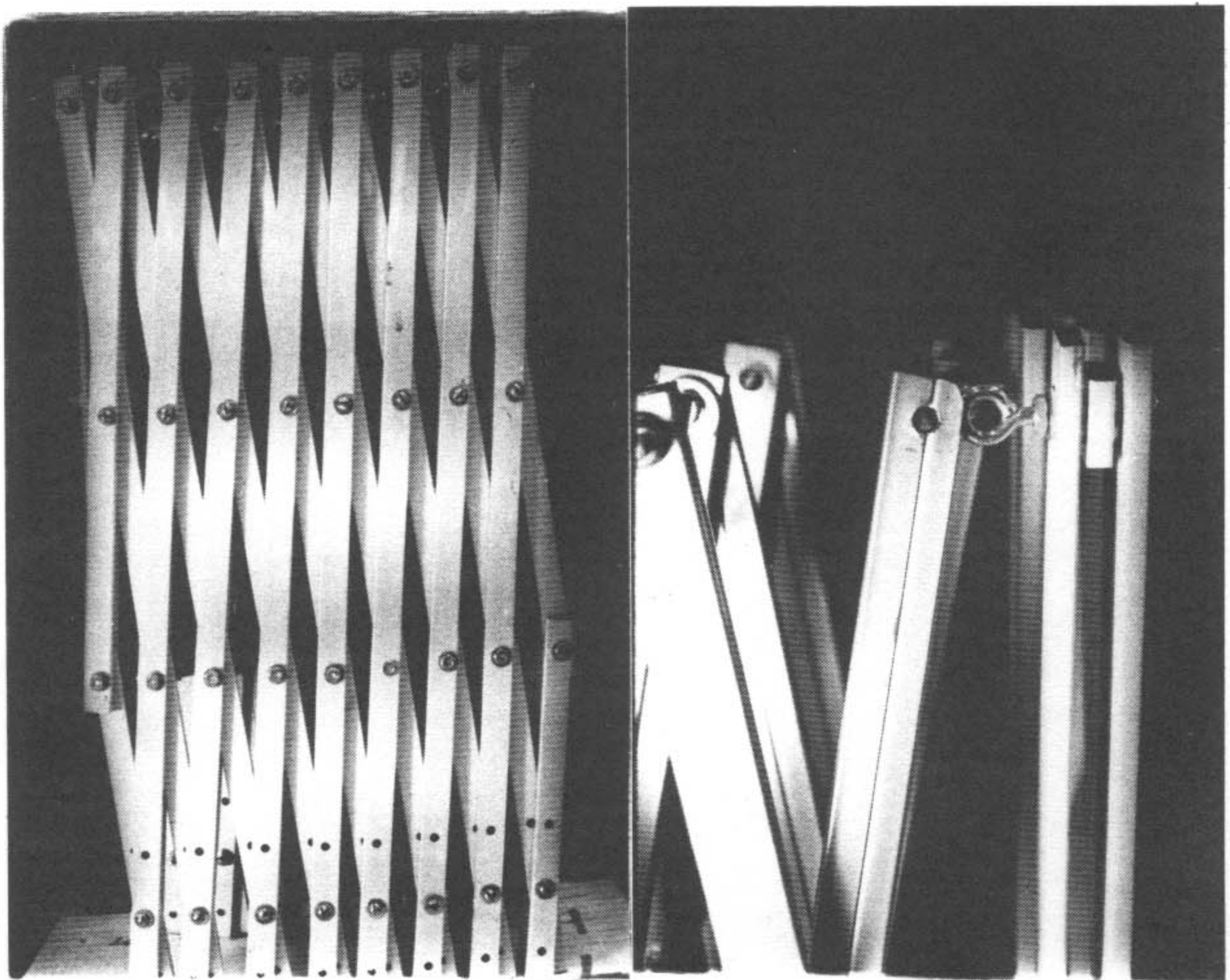

Figure 47

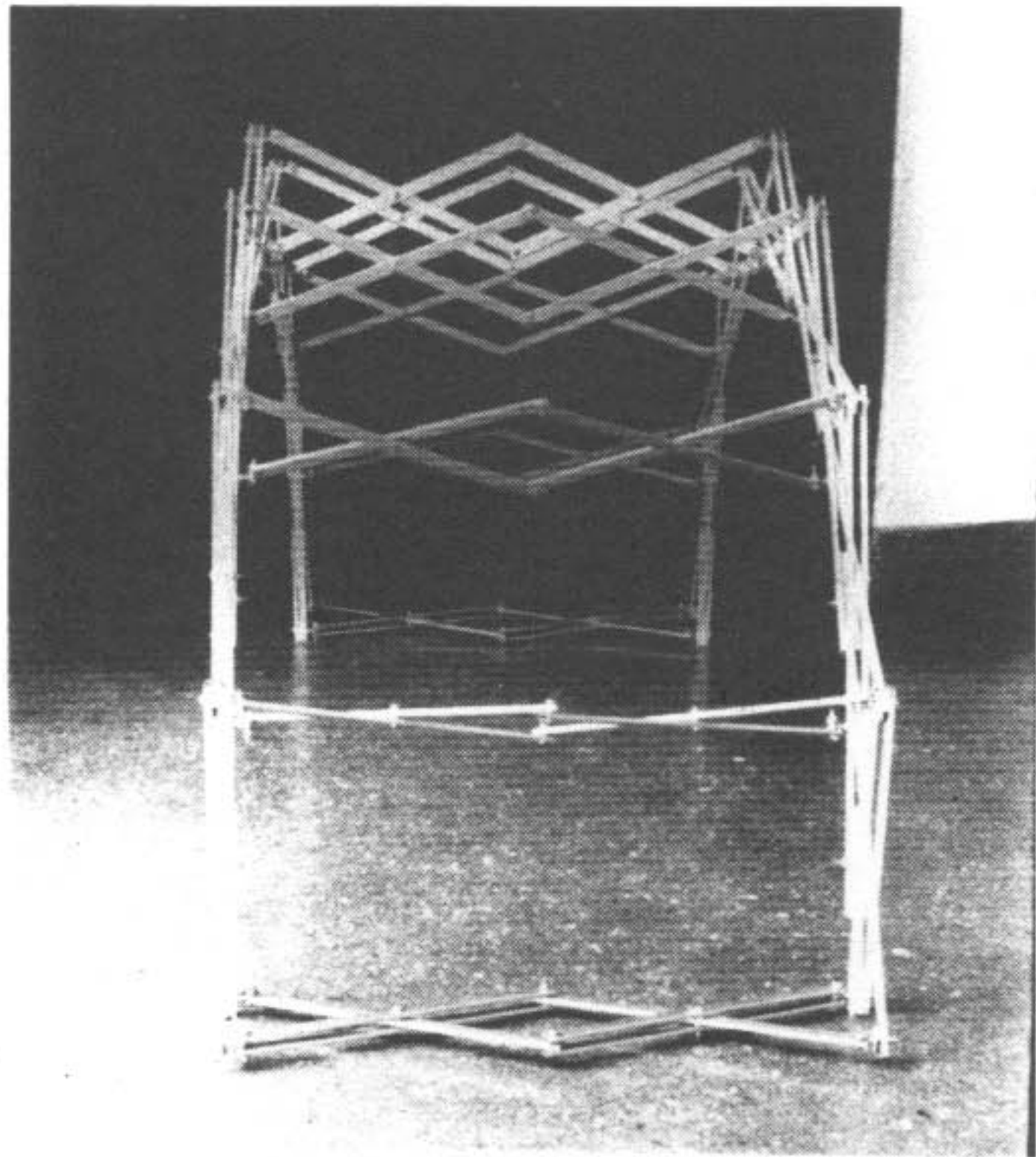

Figure 48

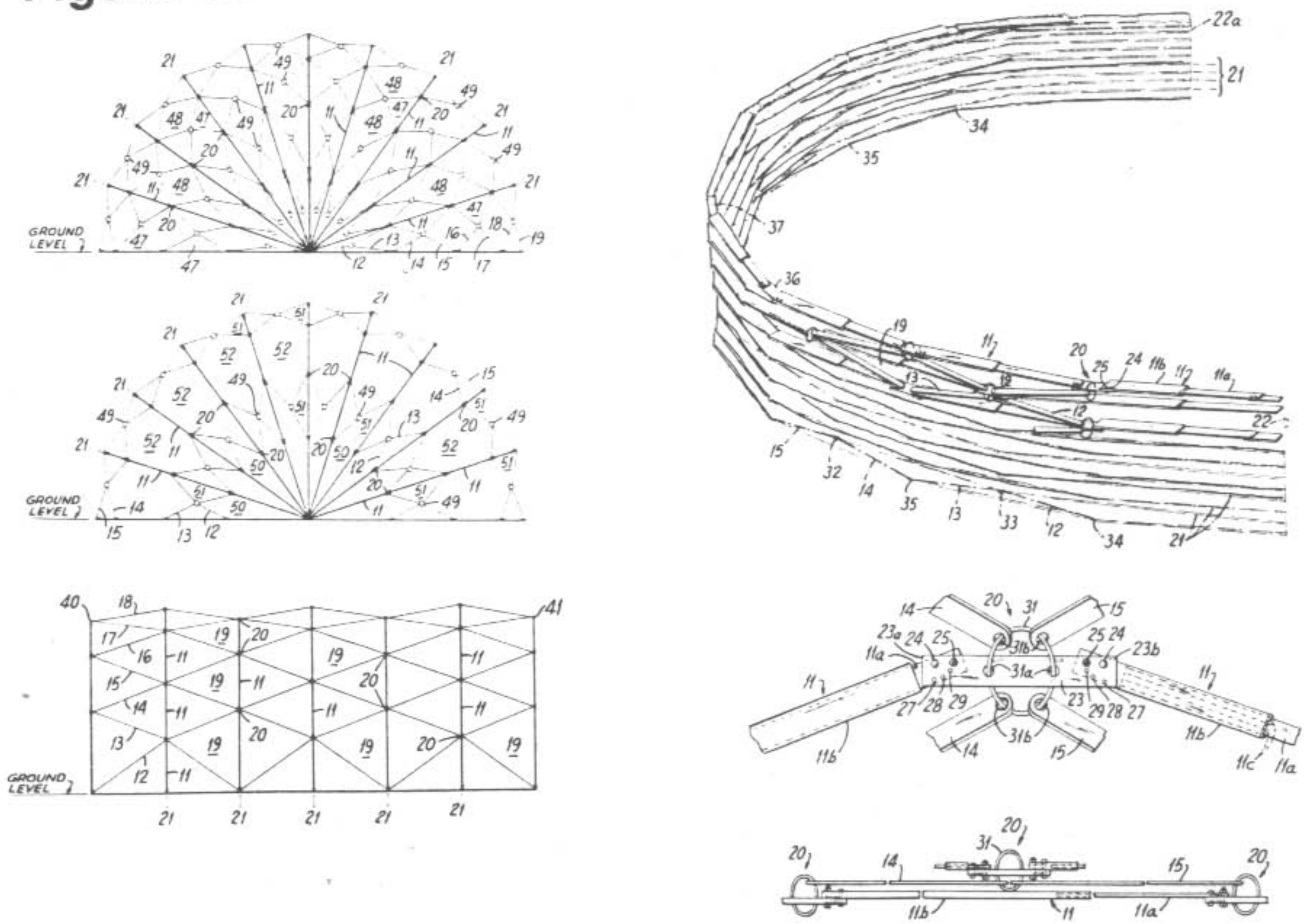

Figure 49

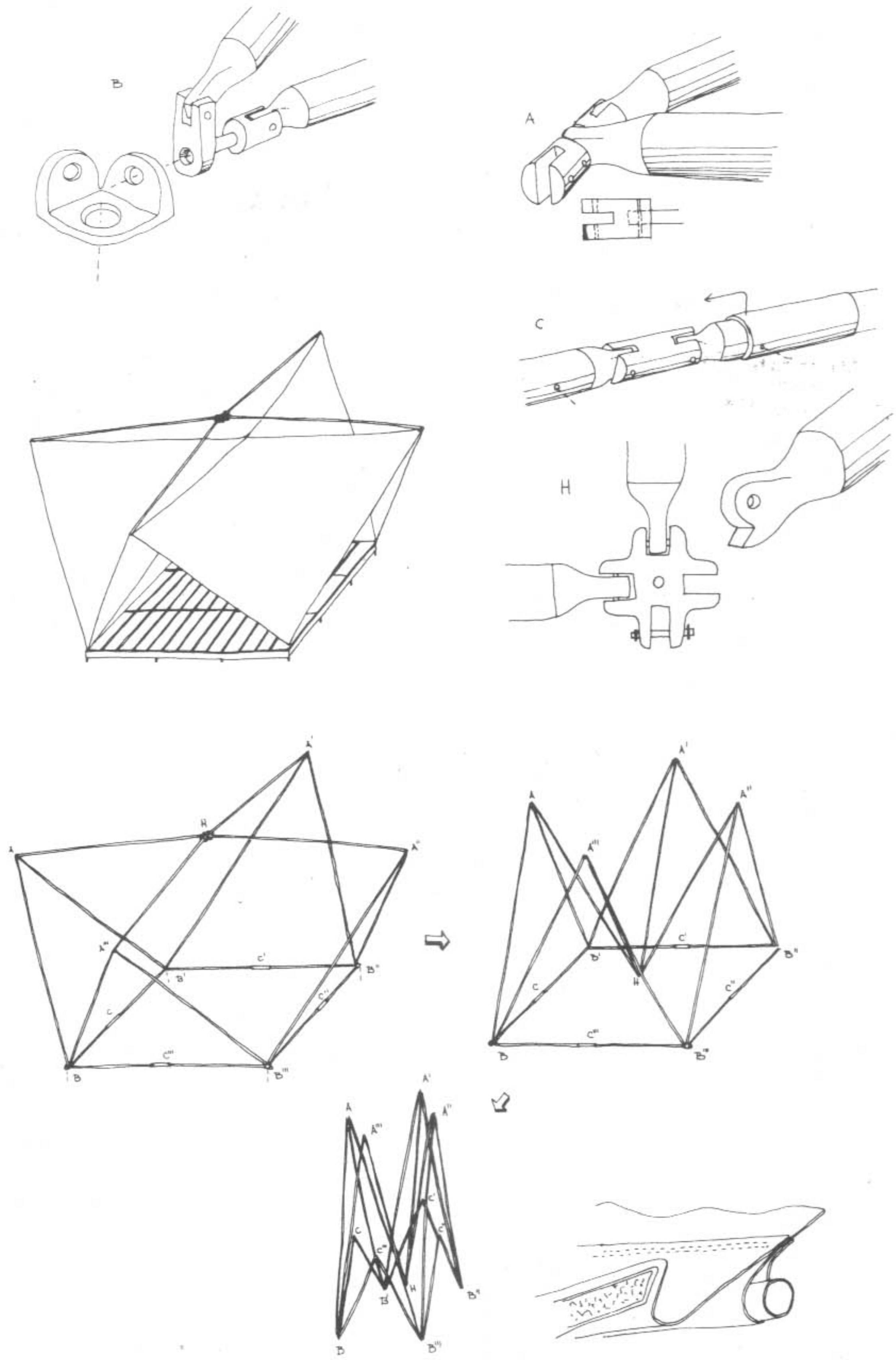

Figure 50

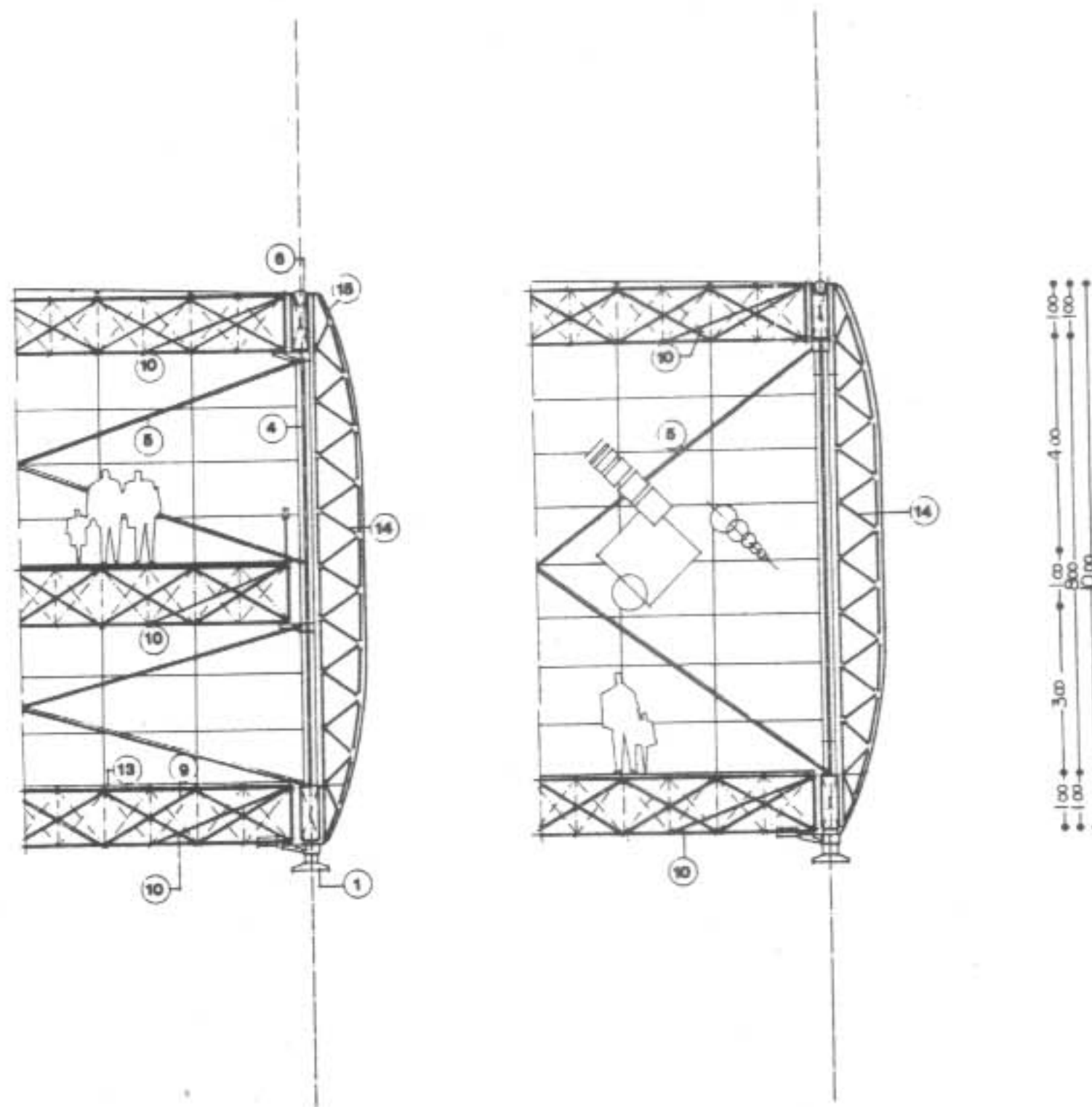
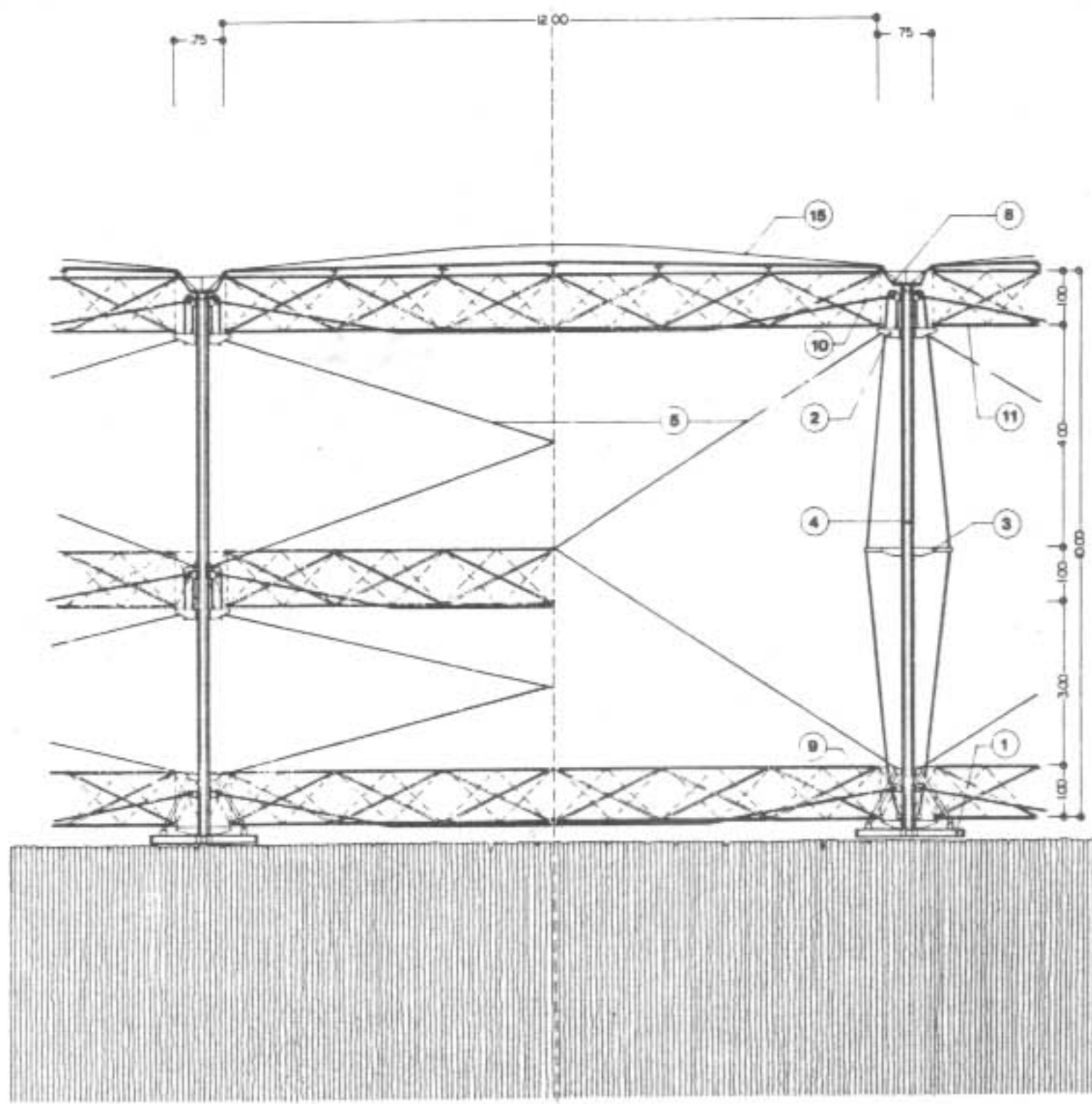

Figure 51

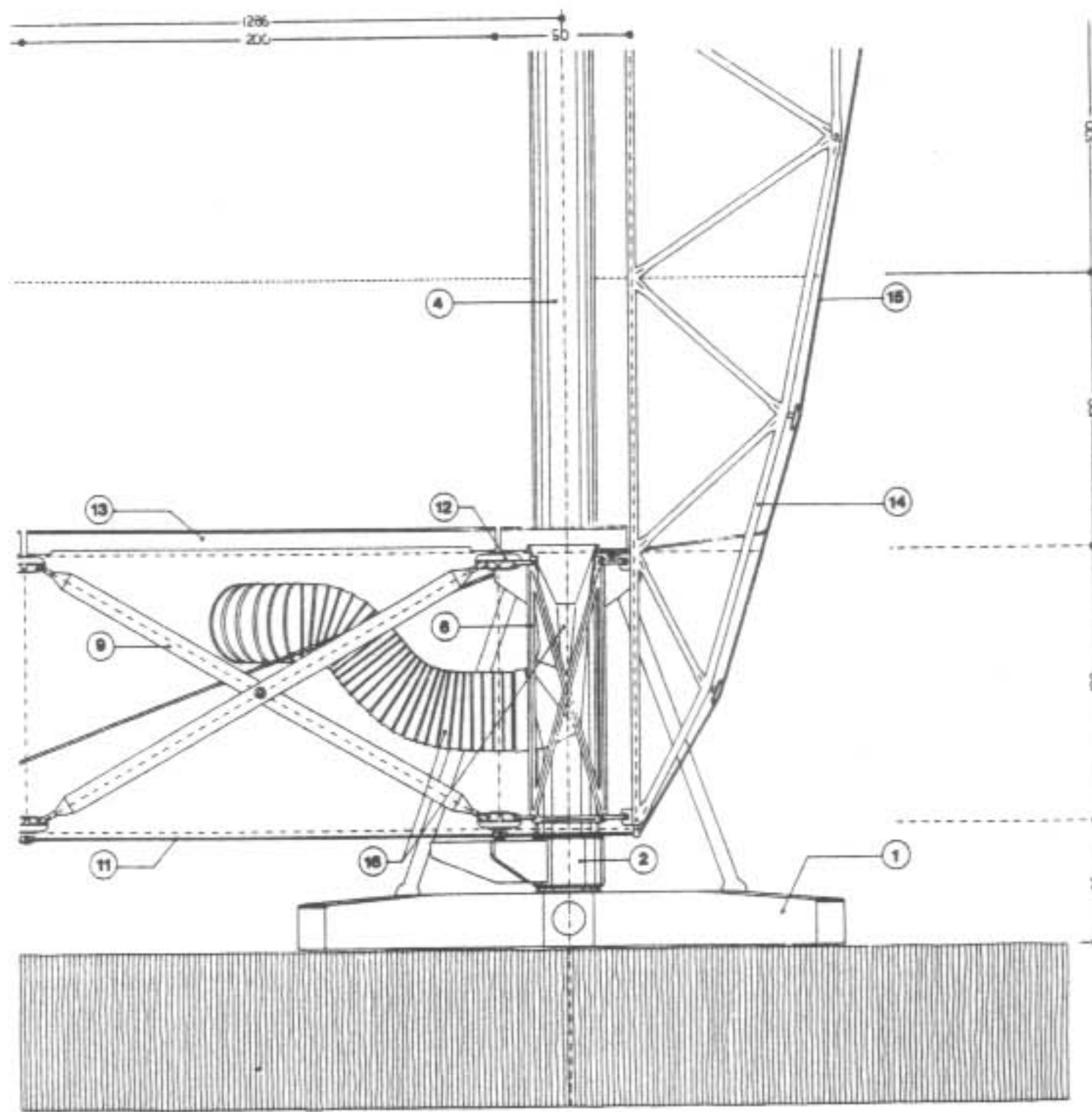
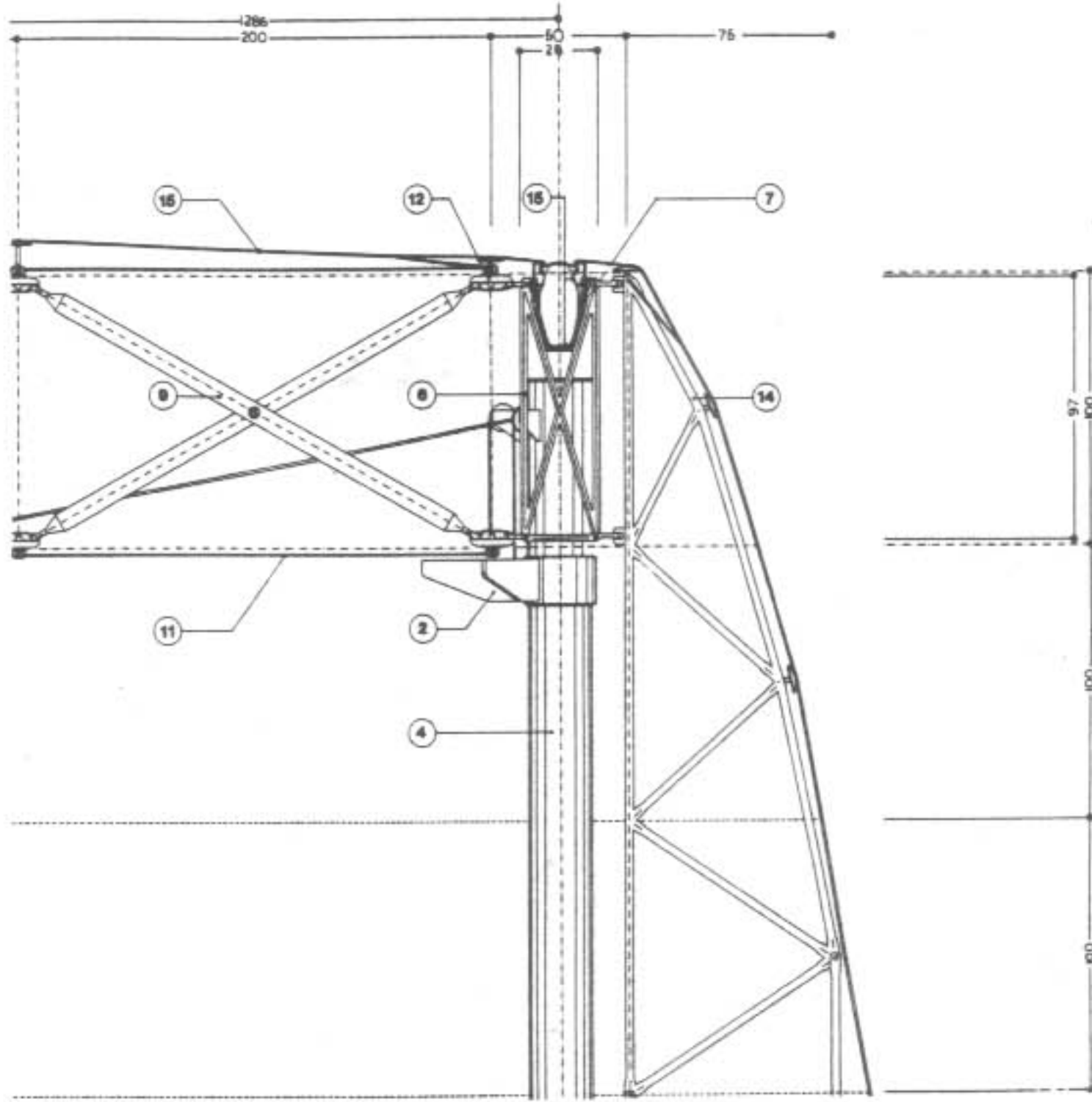

Figure 52

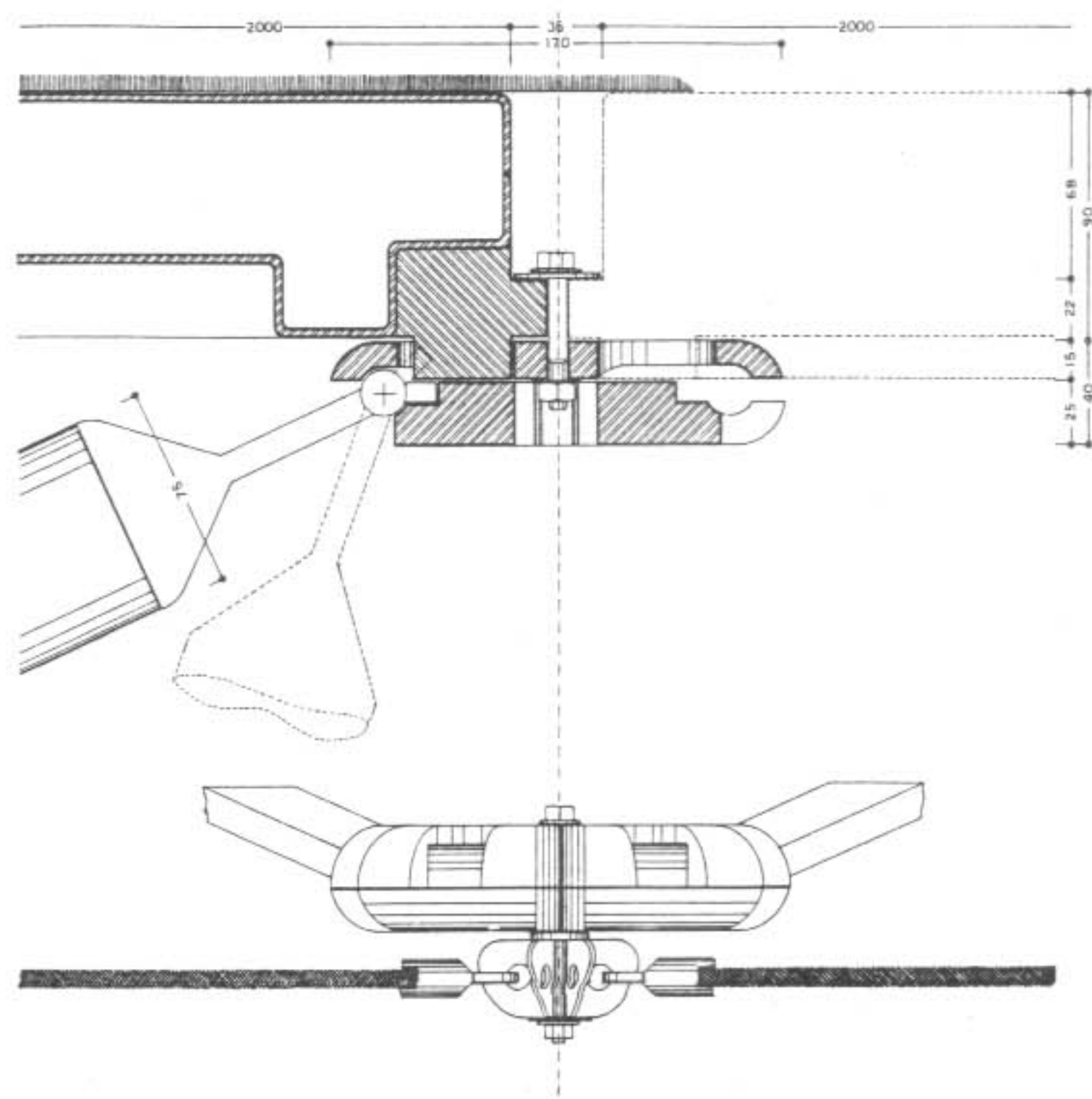
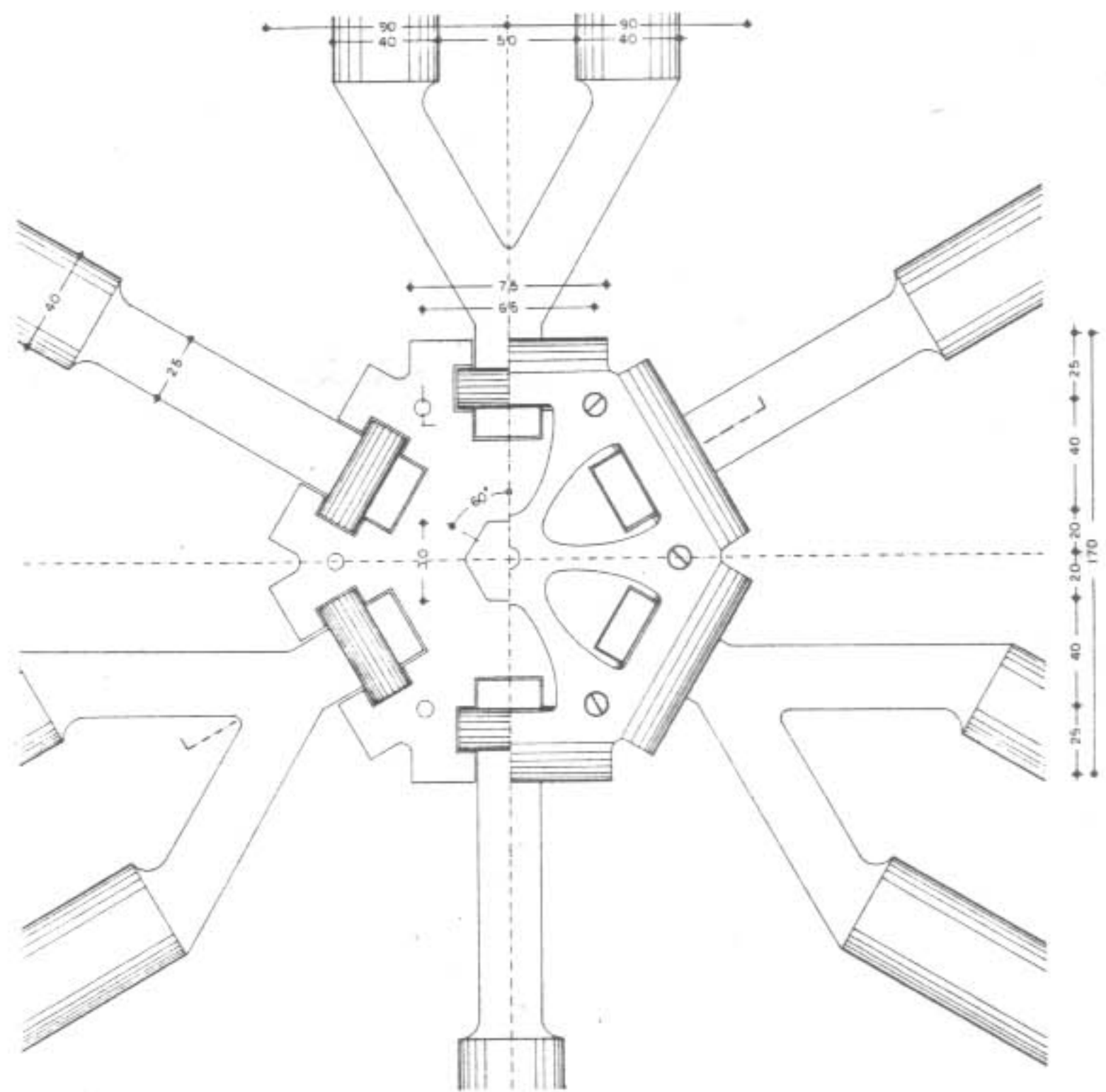

Figure 53

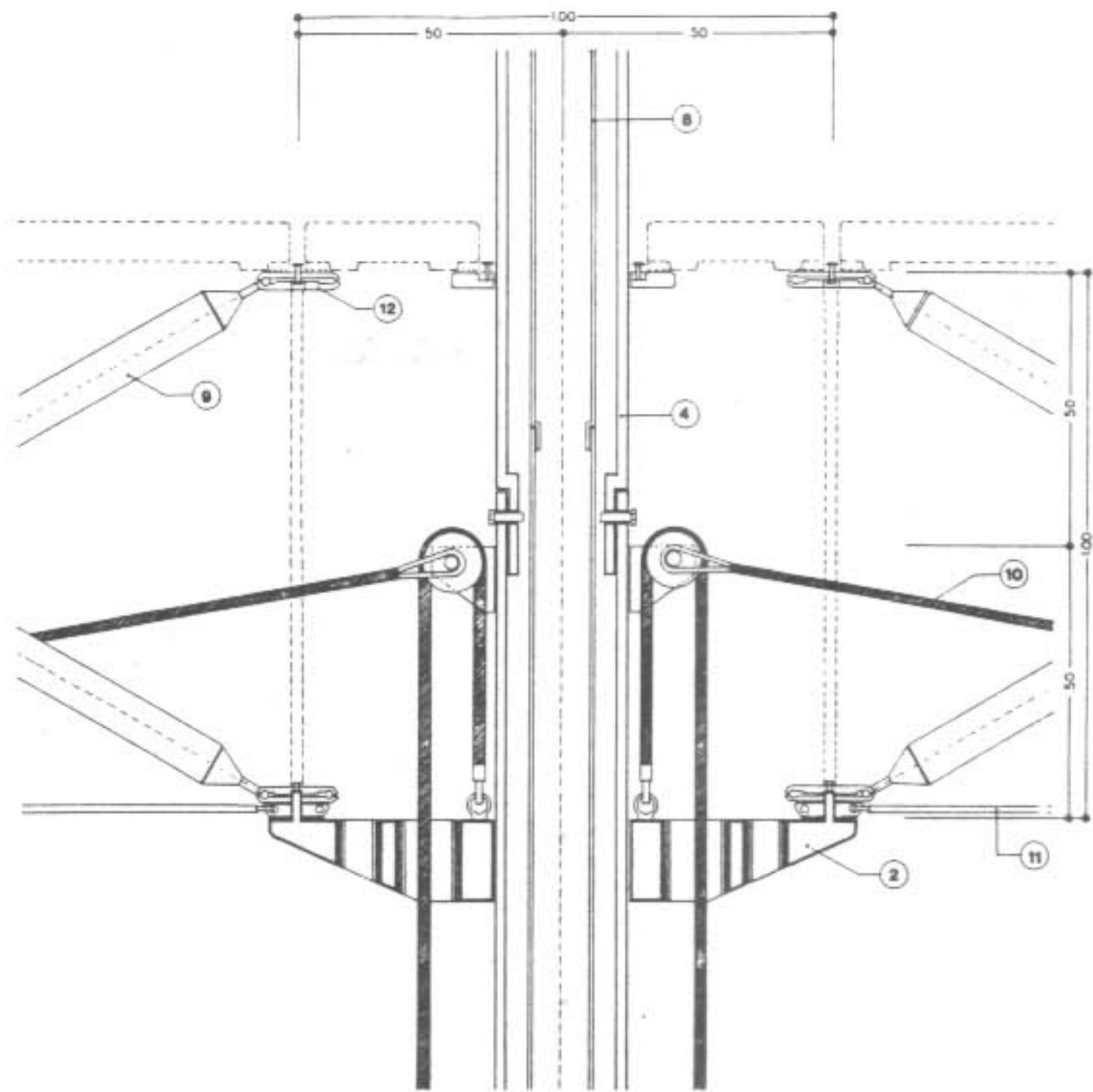

Figure 54

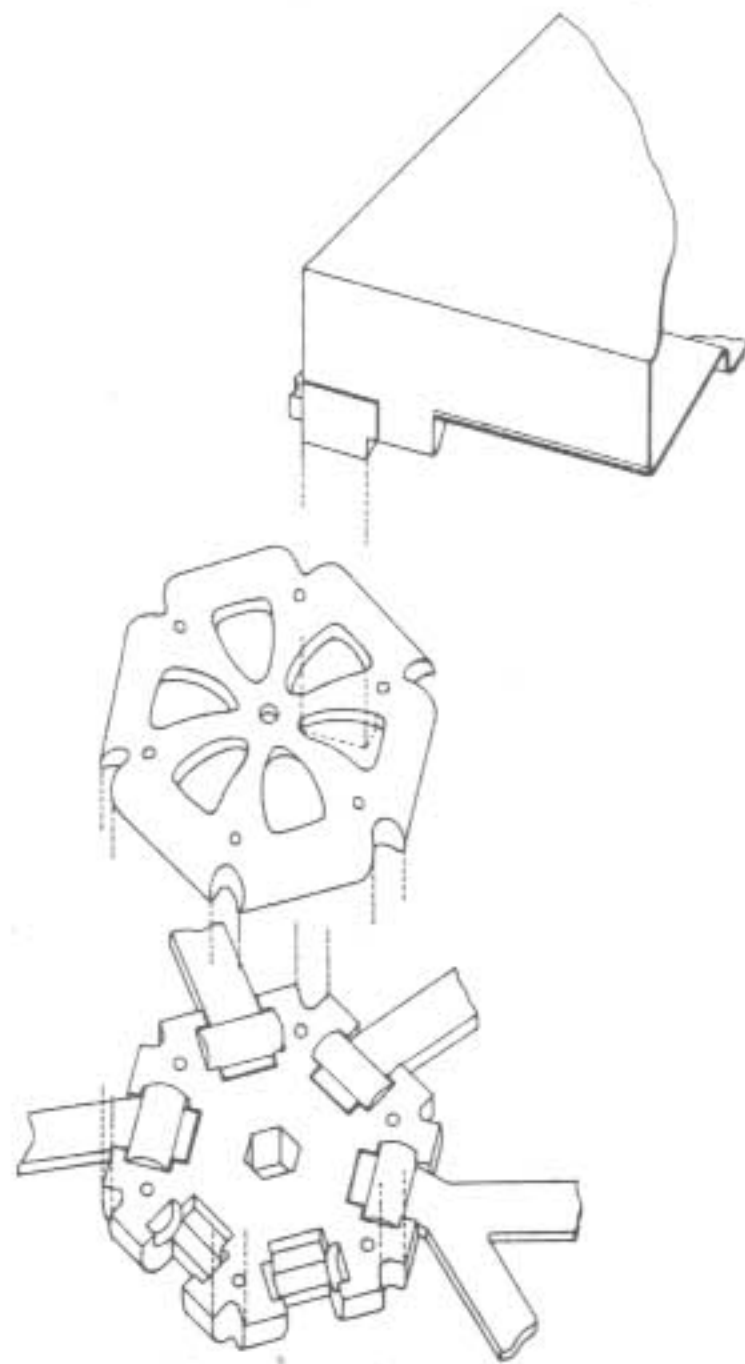

Figure 55

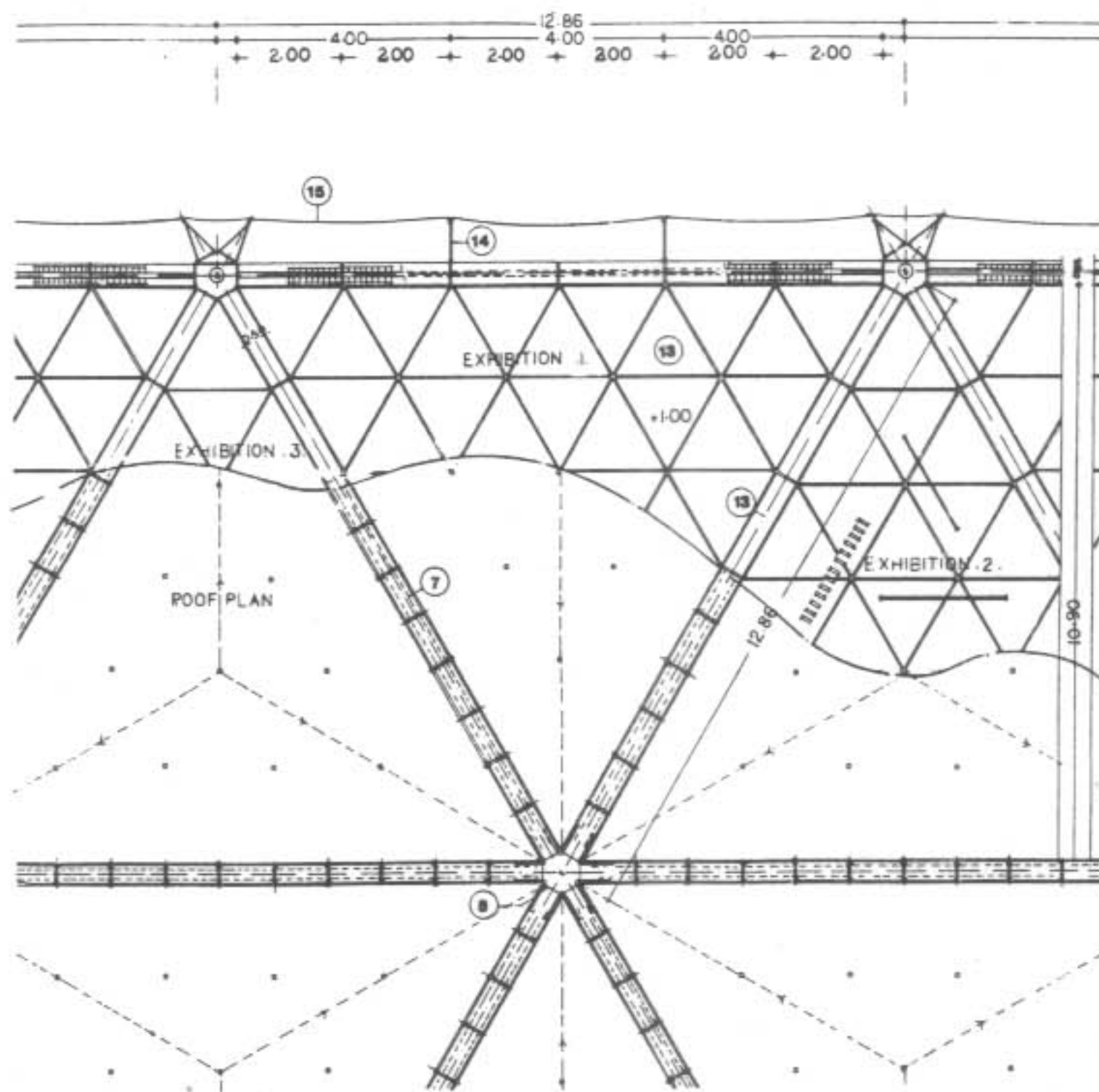
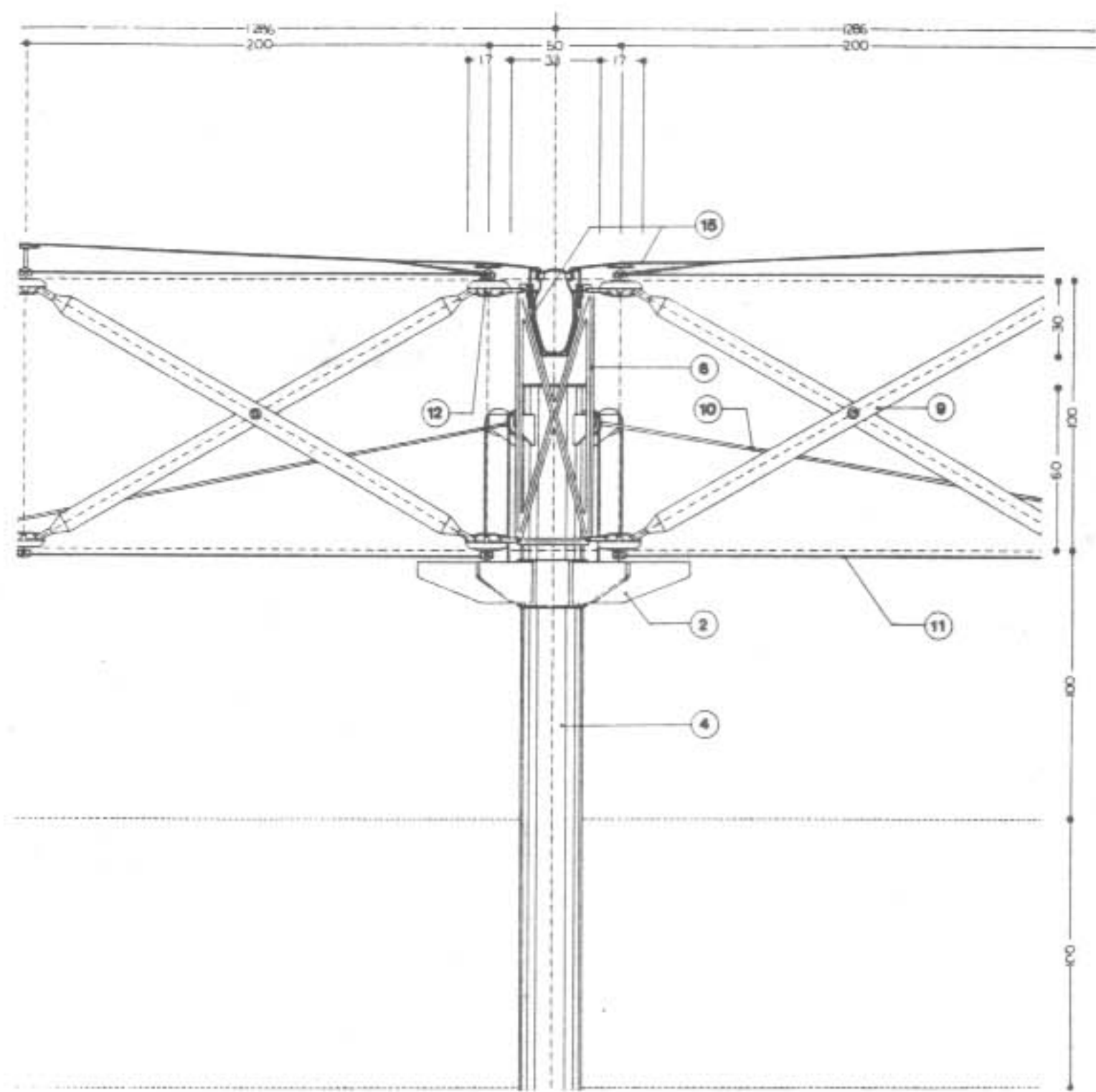

Figure 56

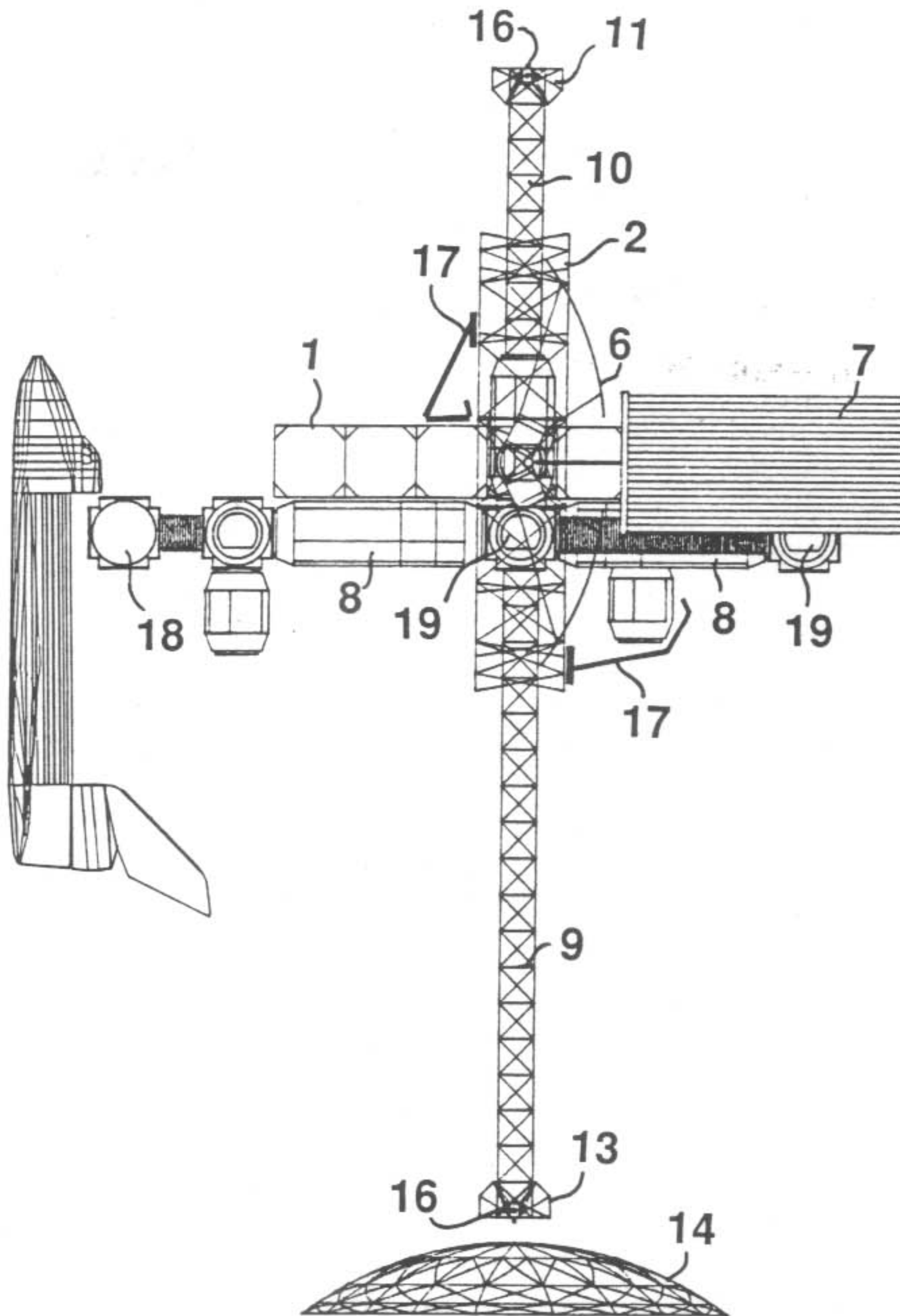

Figure 57

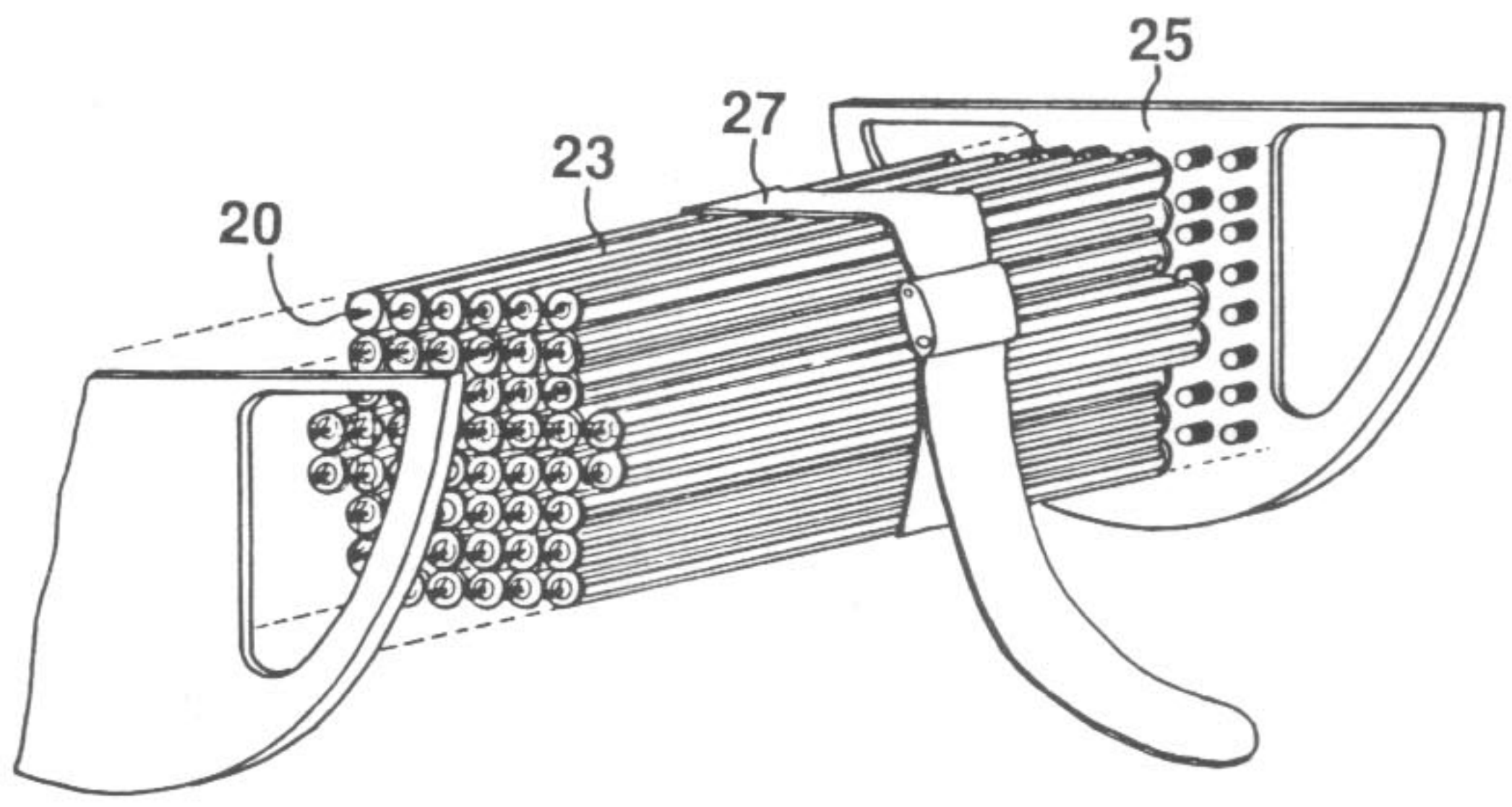
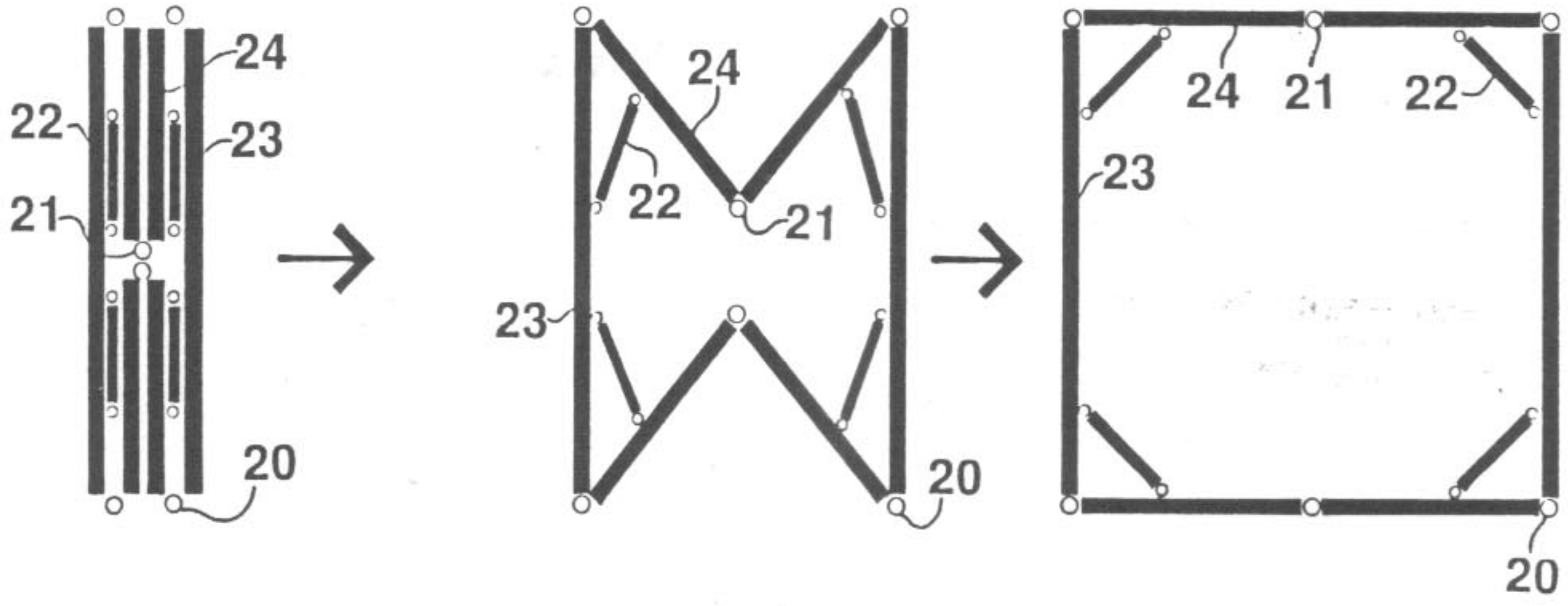

Figure 58

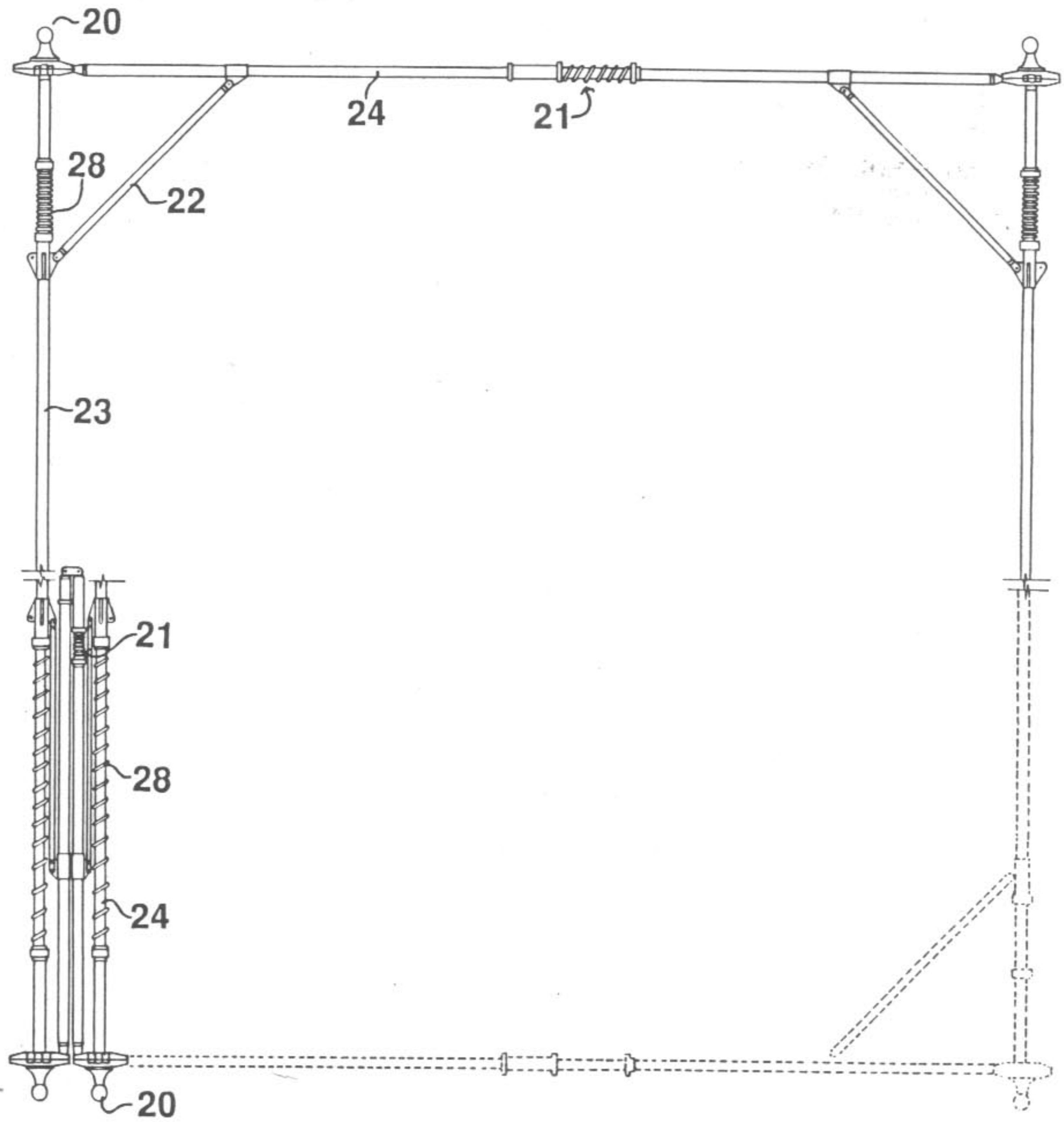

Figure 59

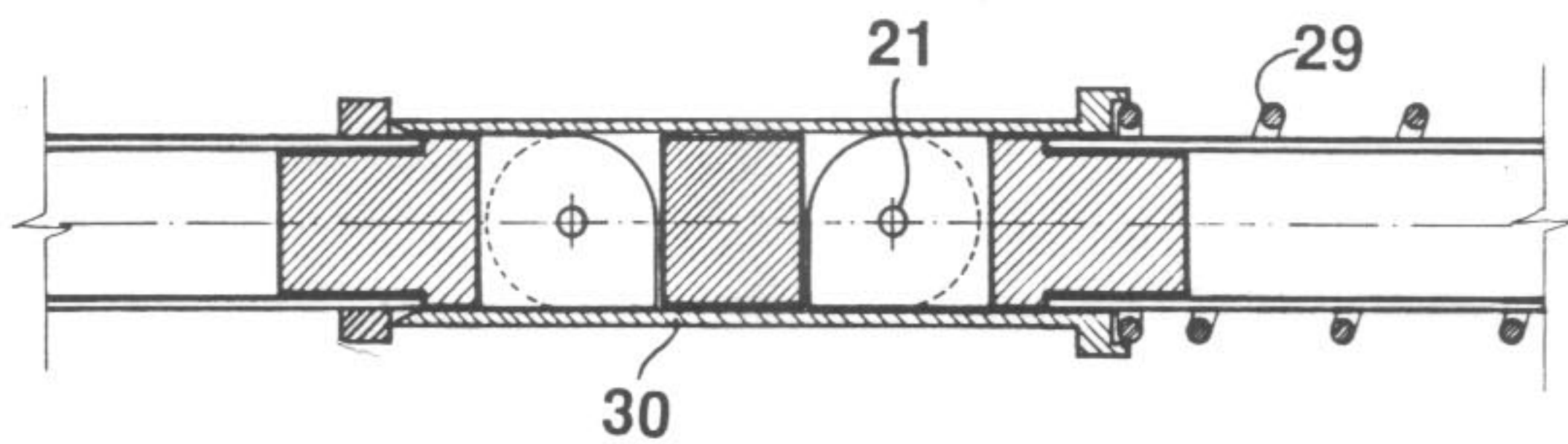
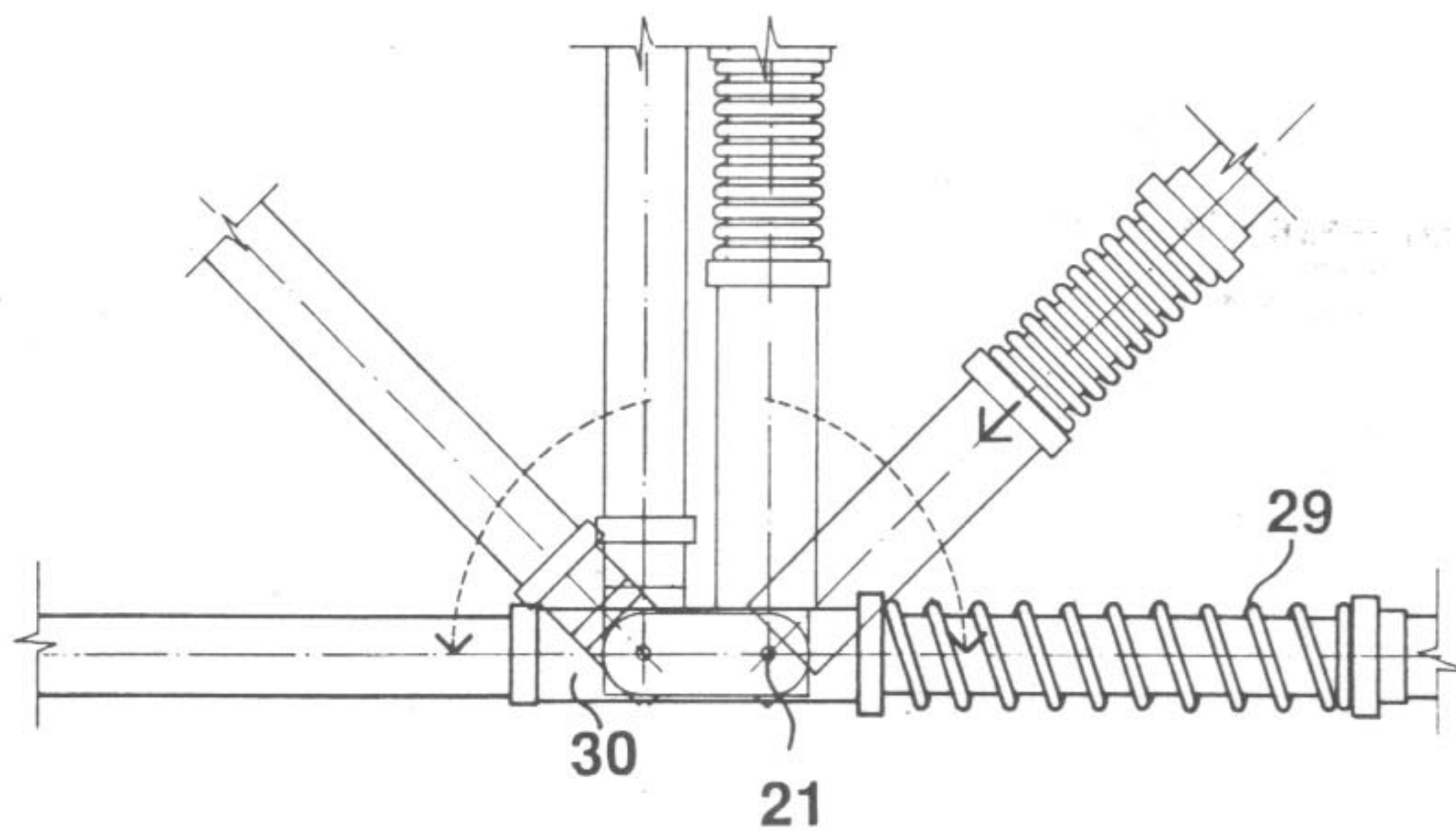

Figure 60

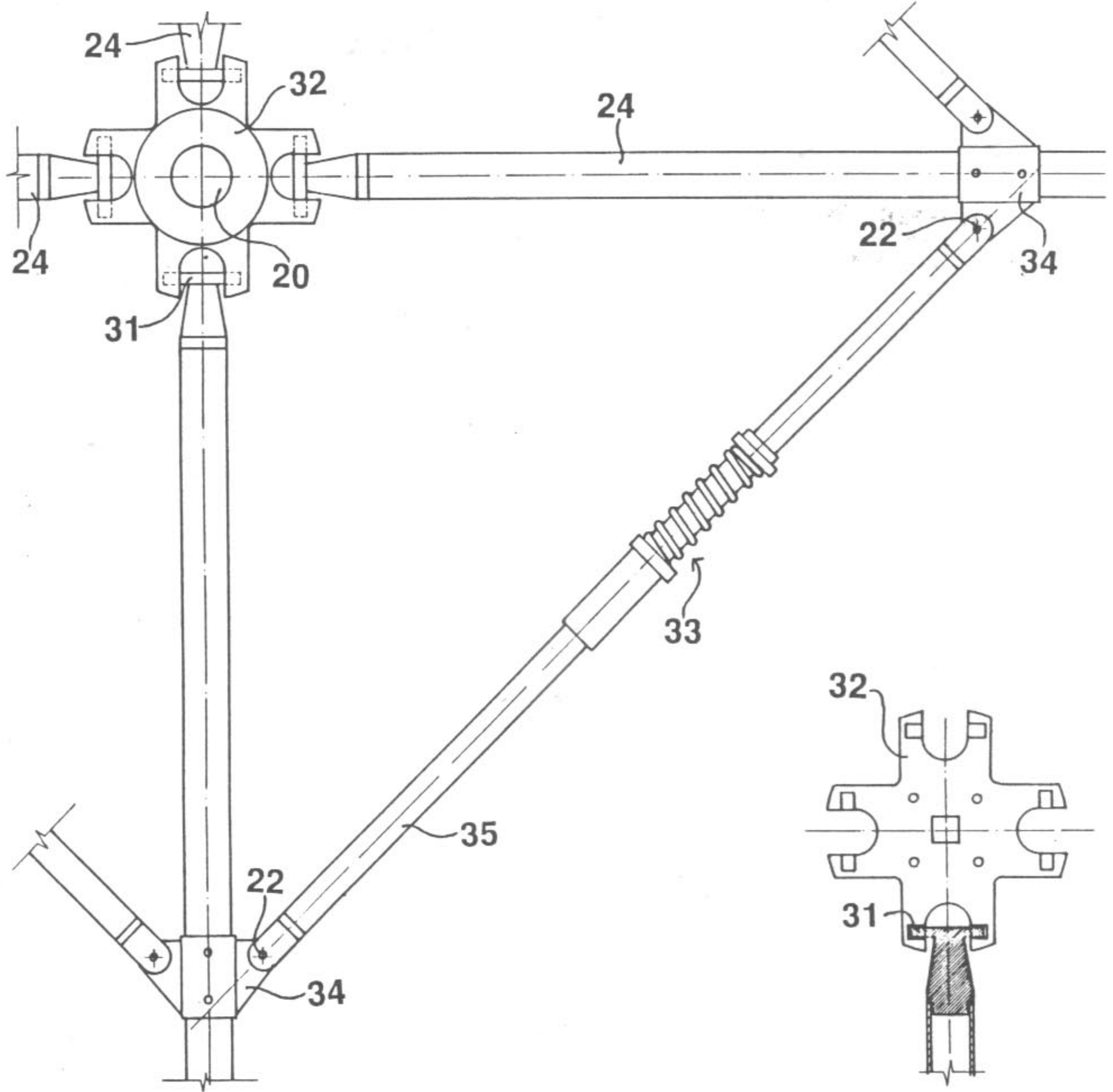

Figure 61

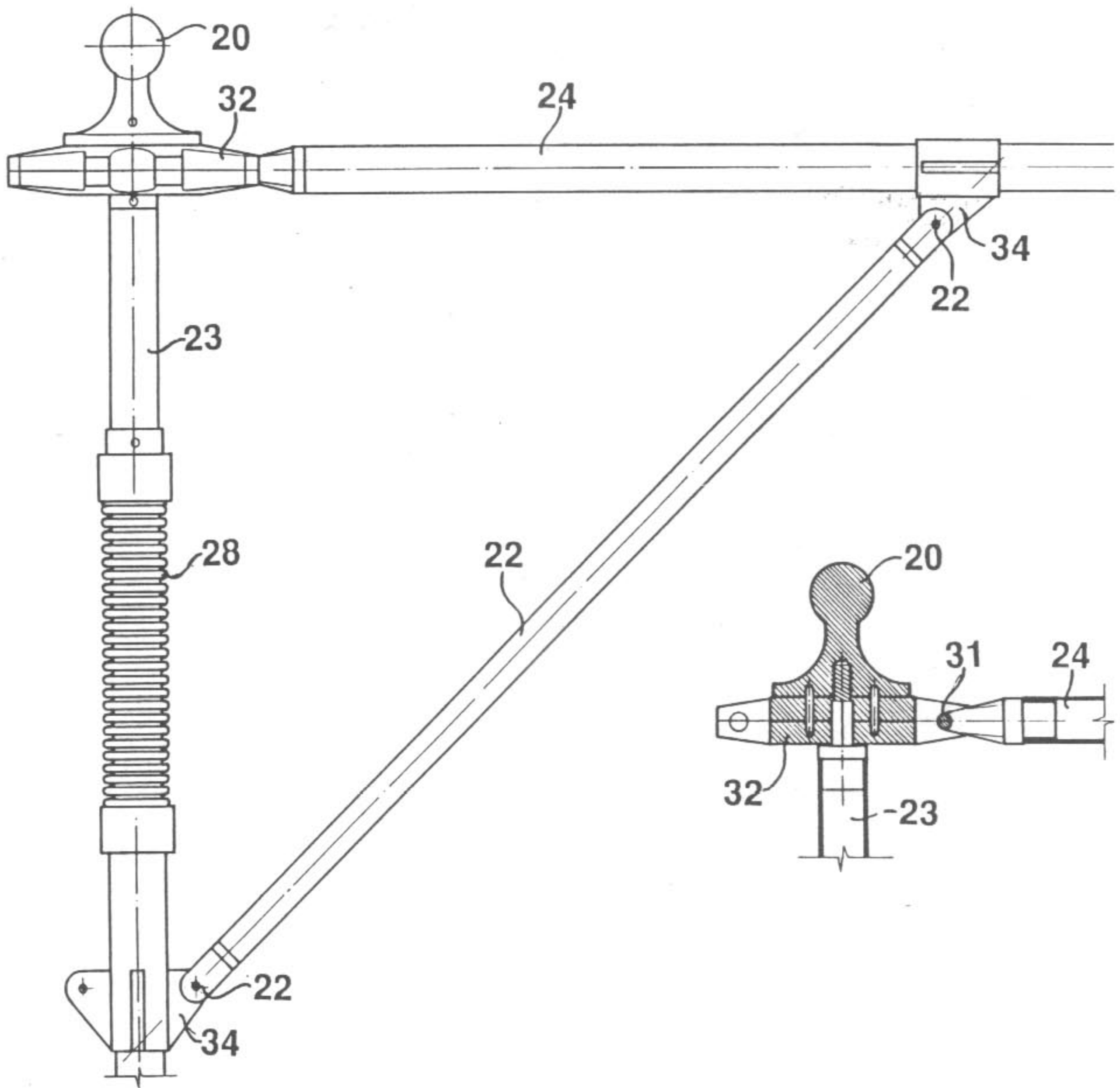

Figure 62

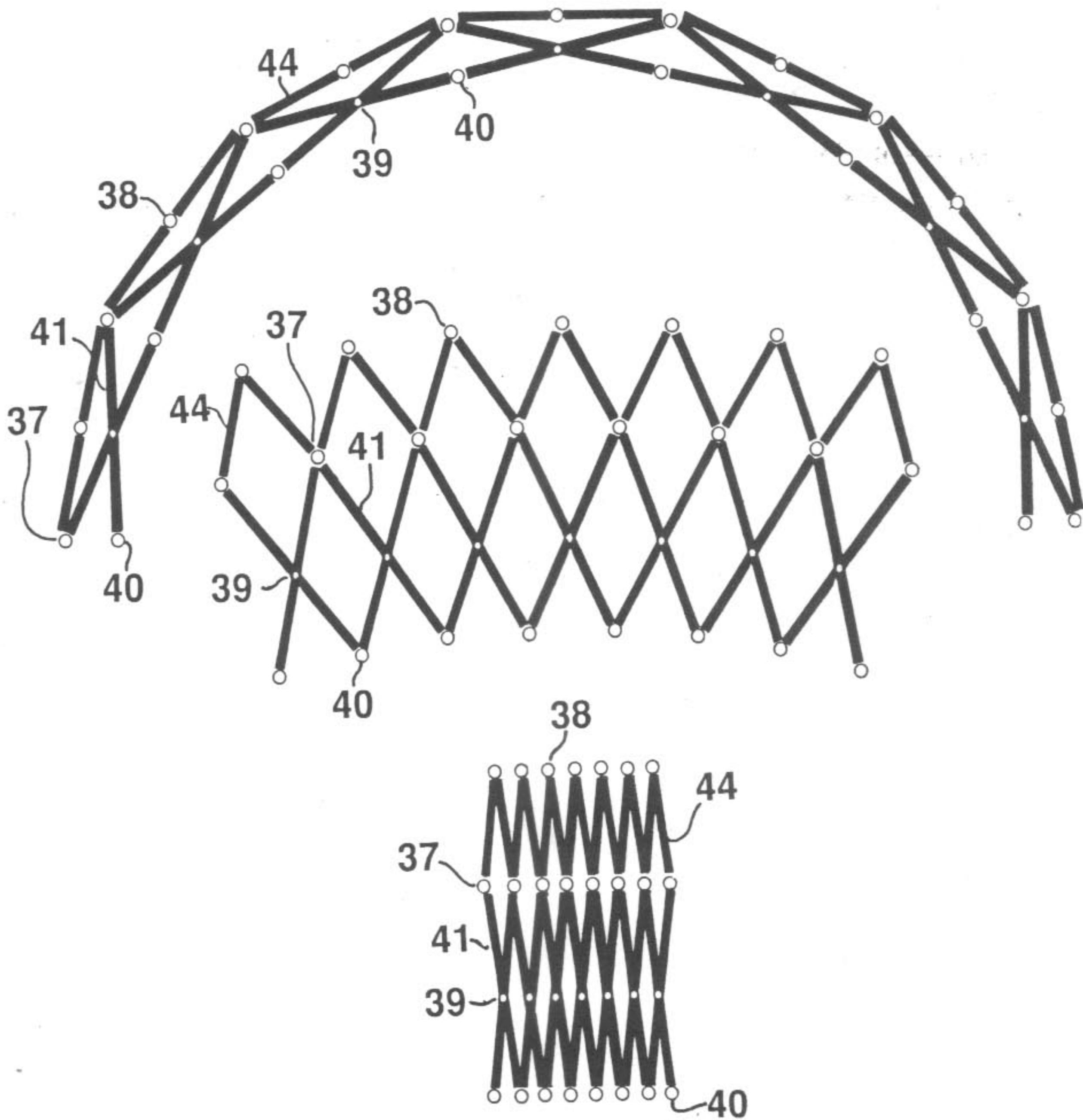

Figure 63

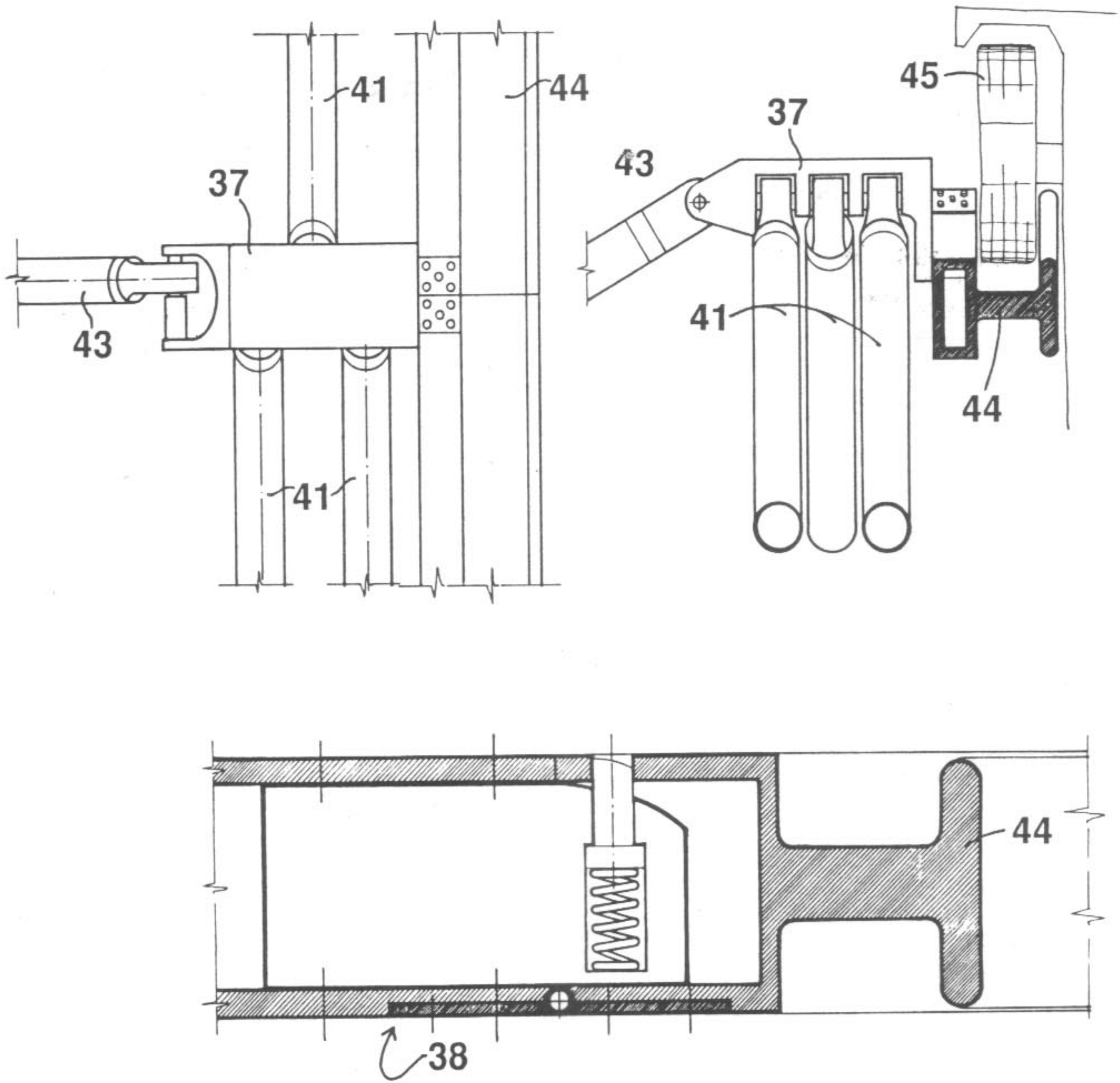

Figure 64

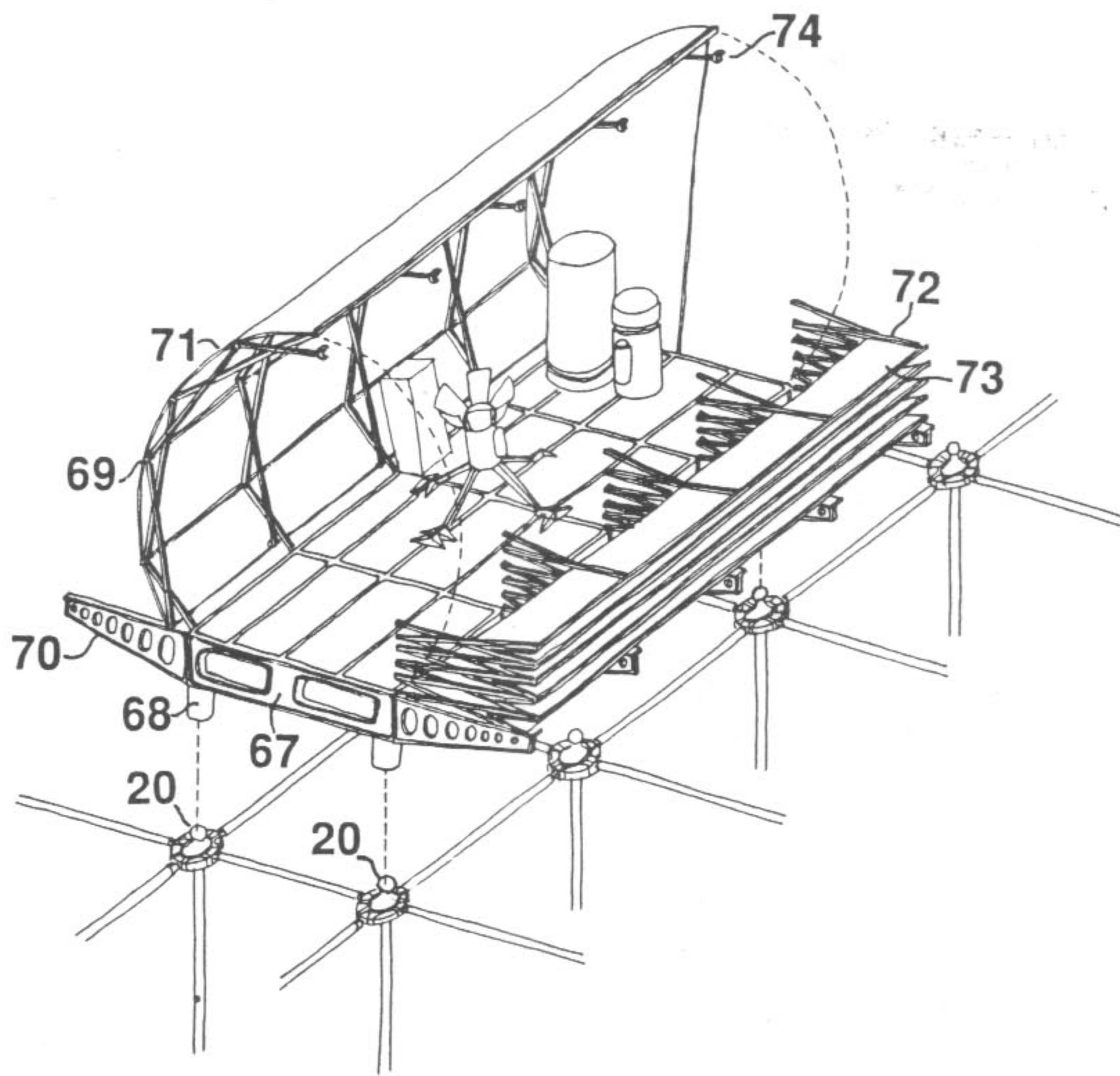

Figure 65



Figure 66

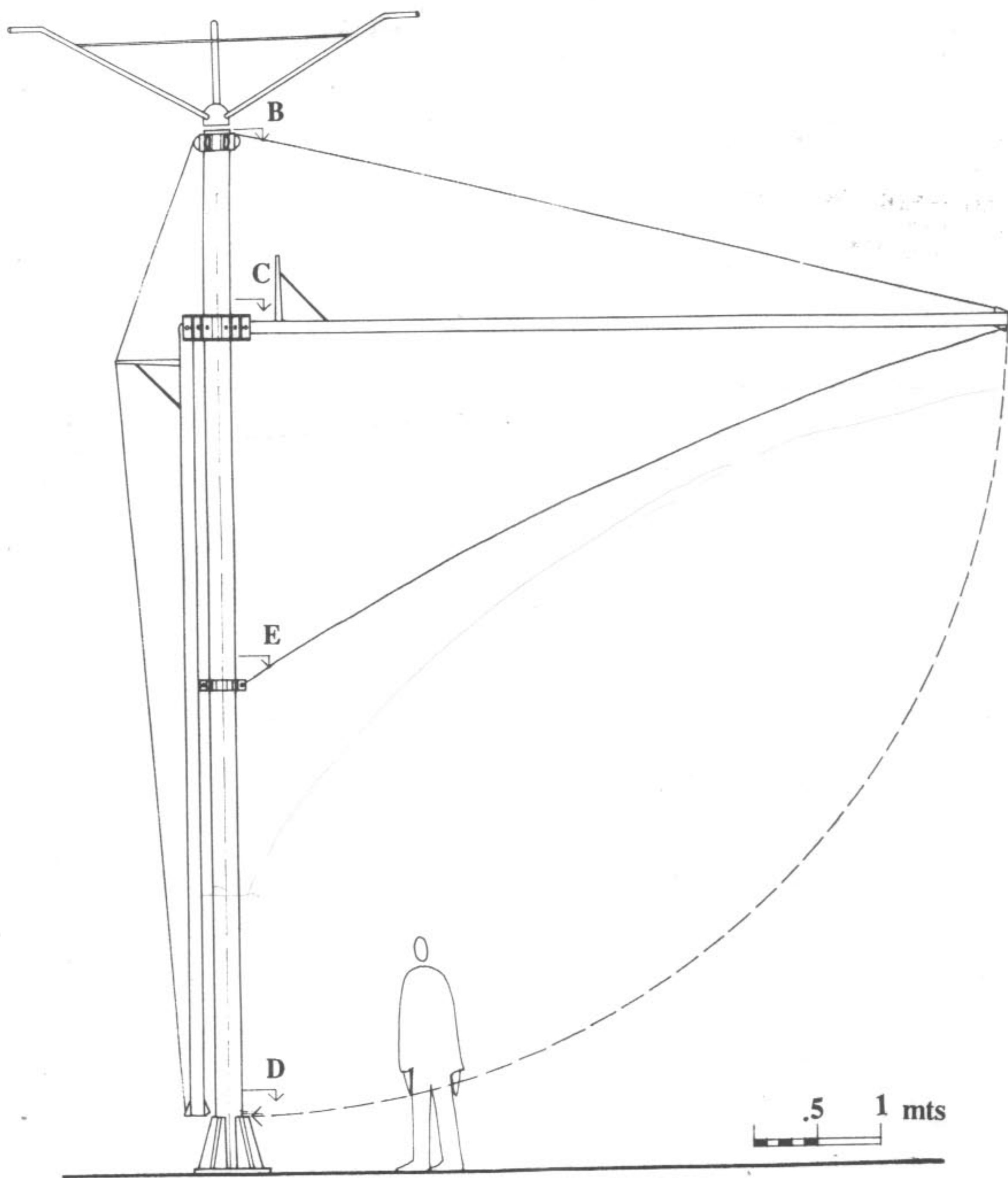

Figure 67

Elevation

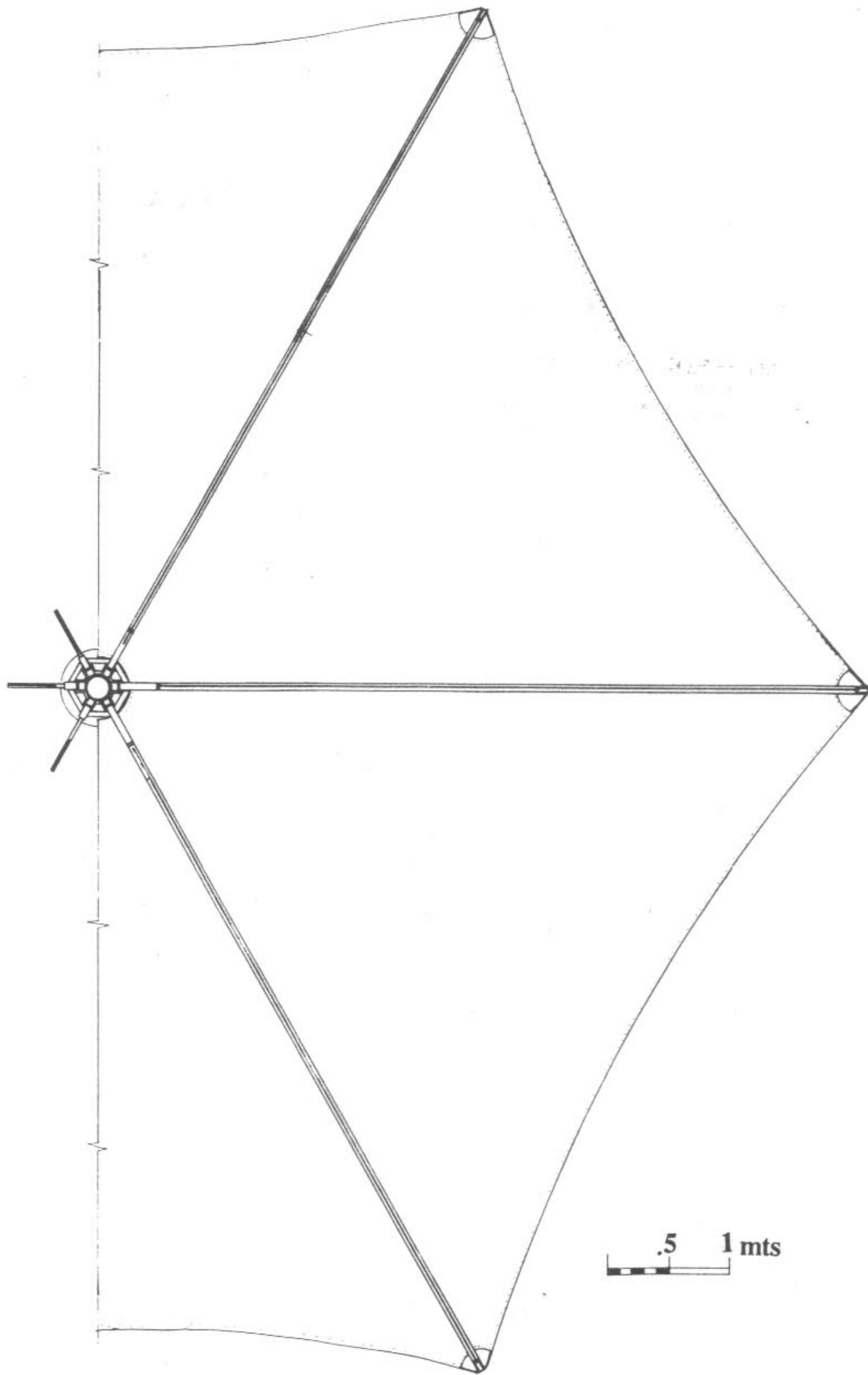

Figure 68

Plan

Section B

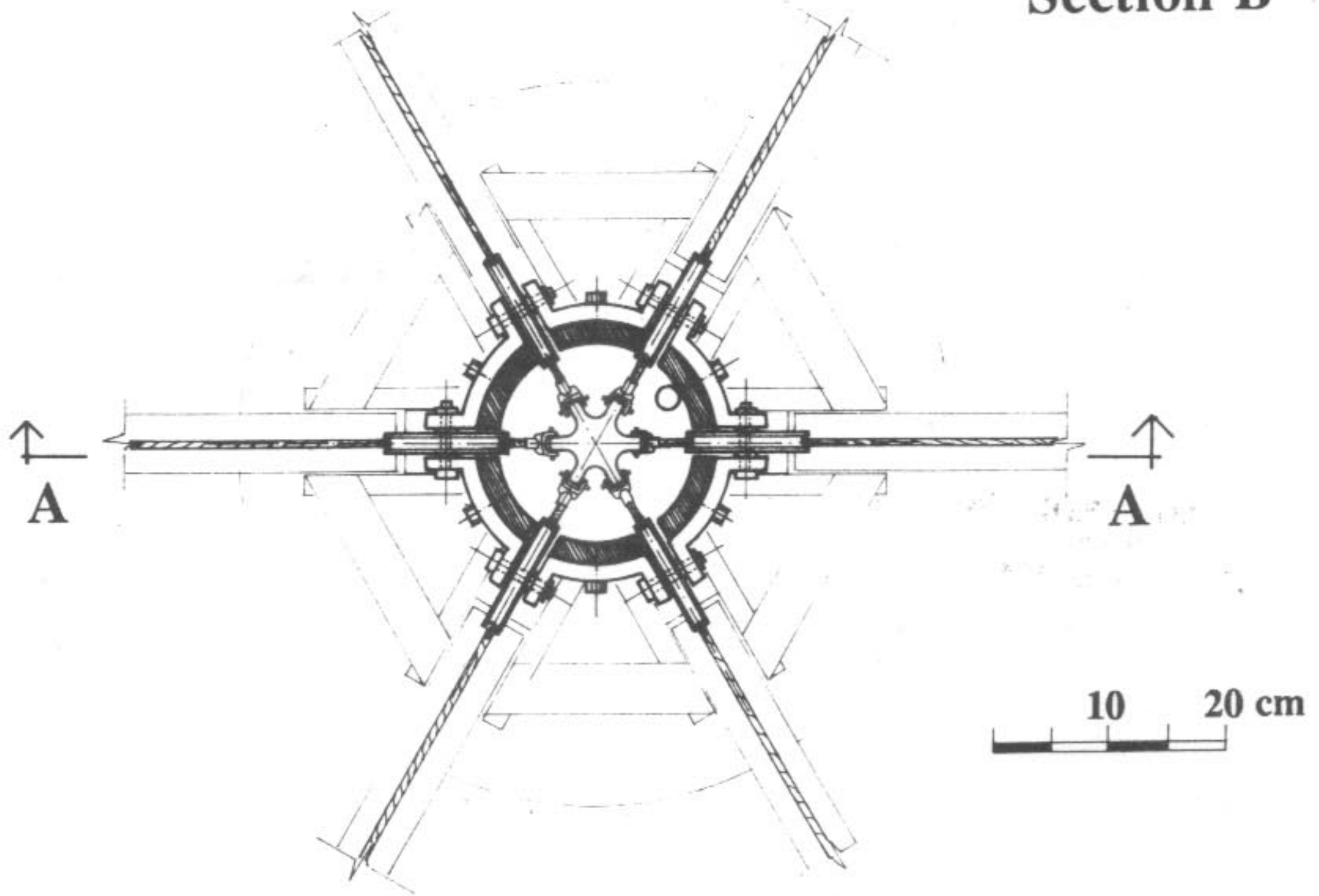

Figure 69

Section C

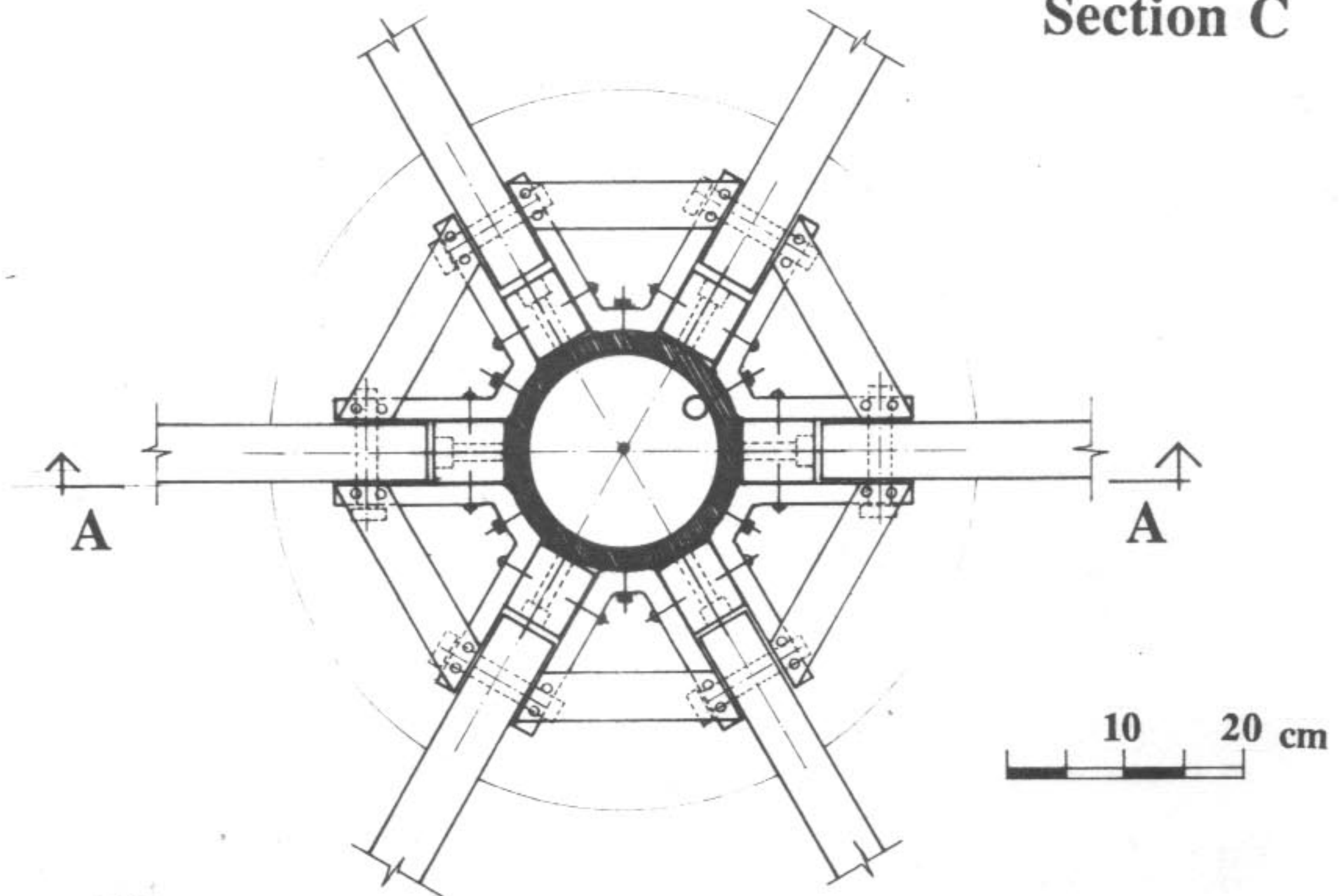

Figure 70

Section D

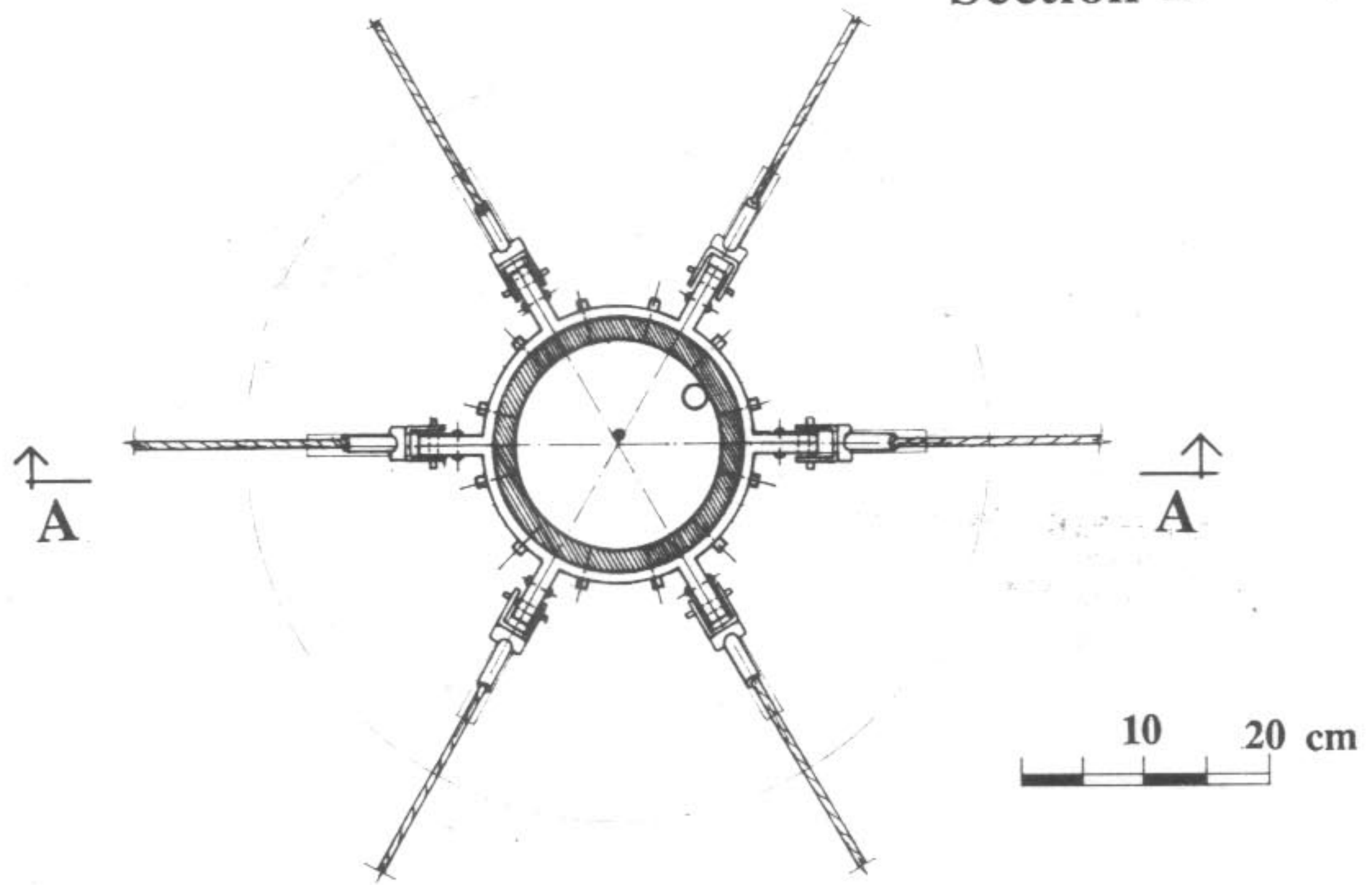

Figure 71

Section E

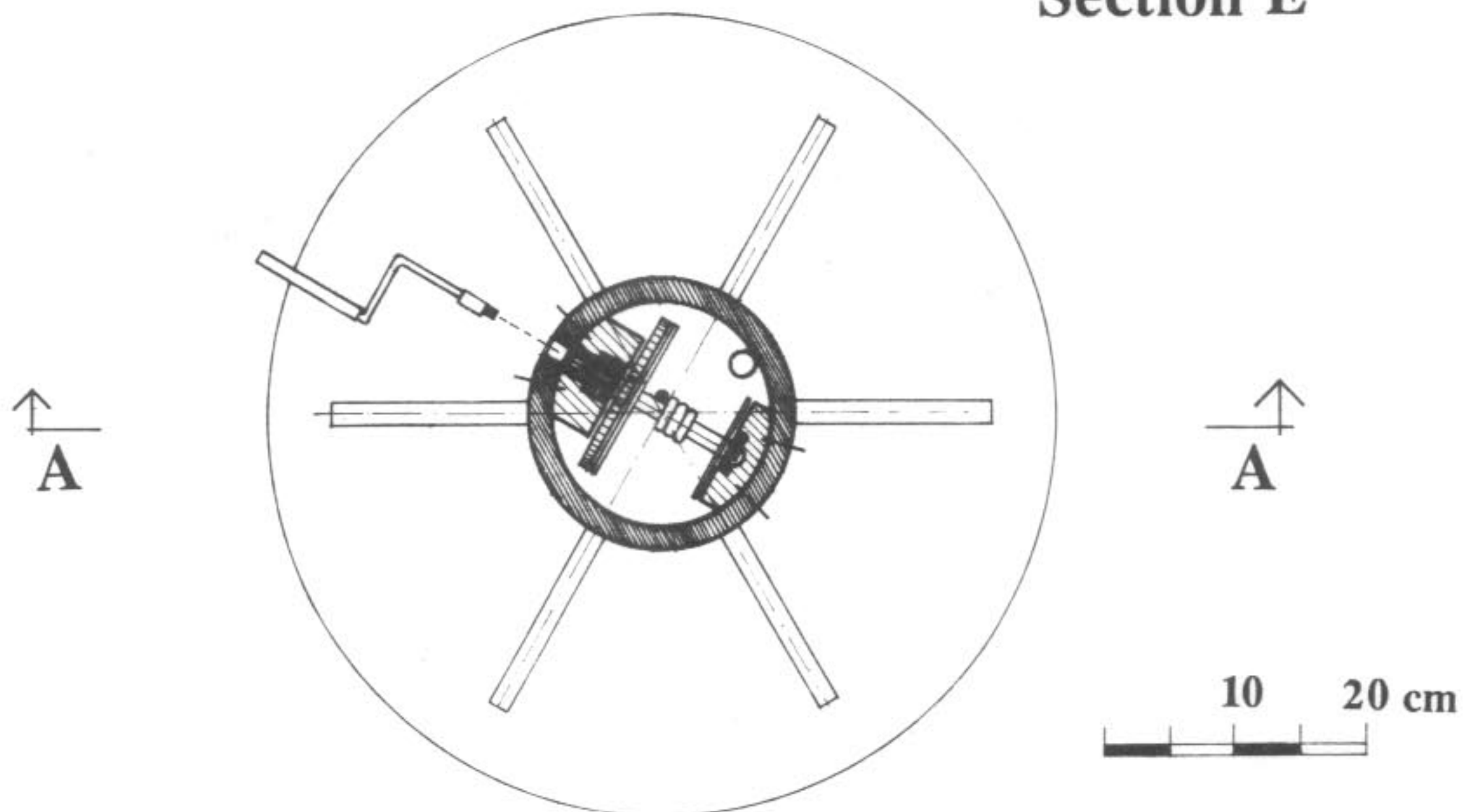

Figure 72

Section A

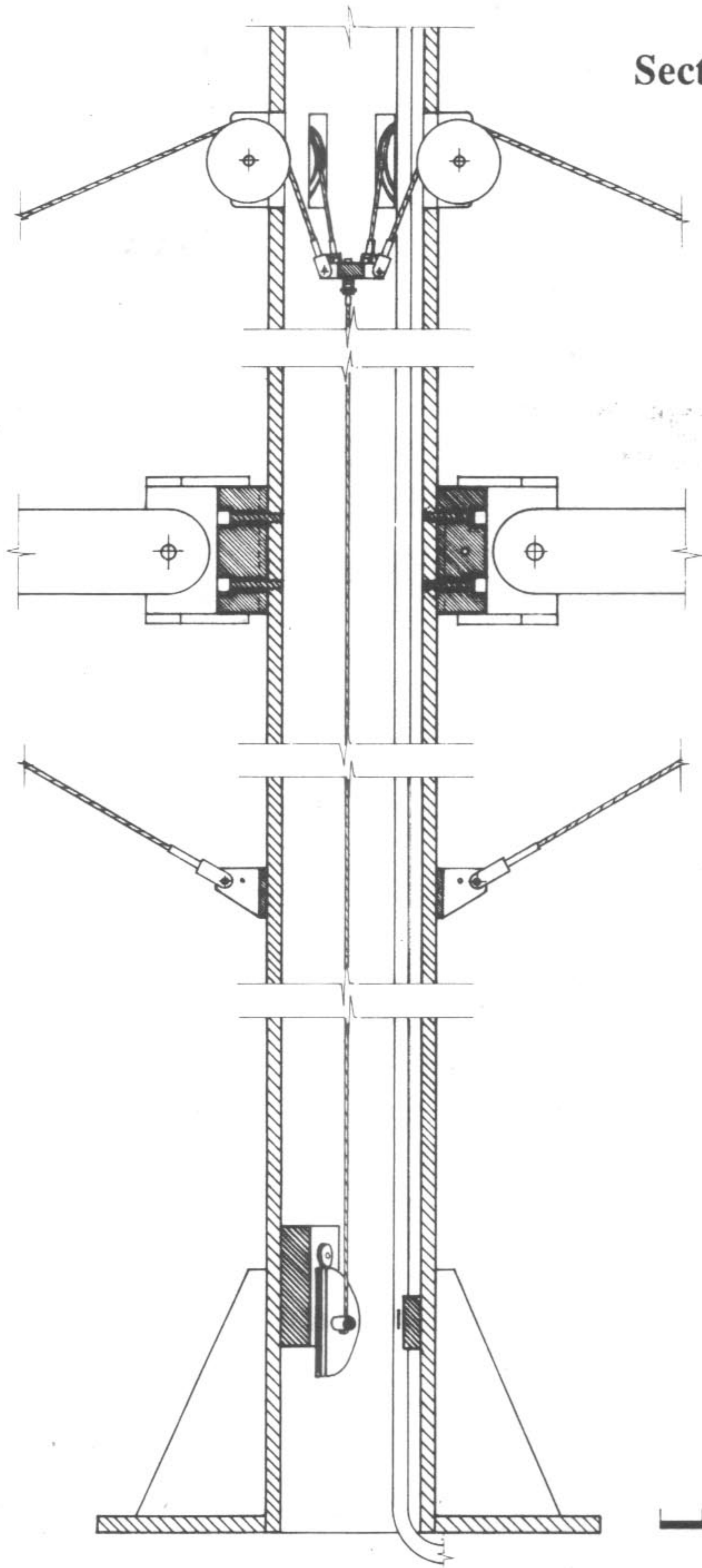

Figure 73

Detail

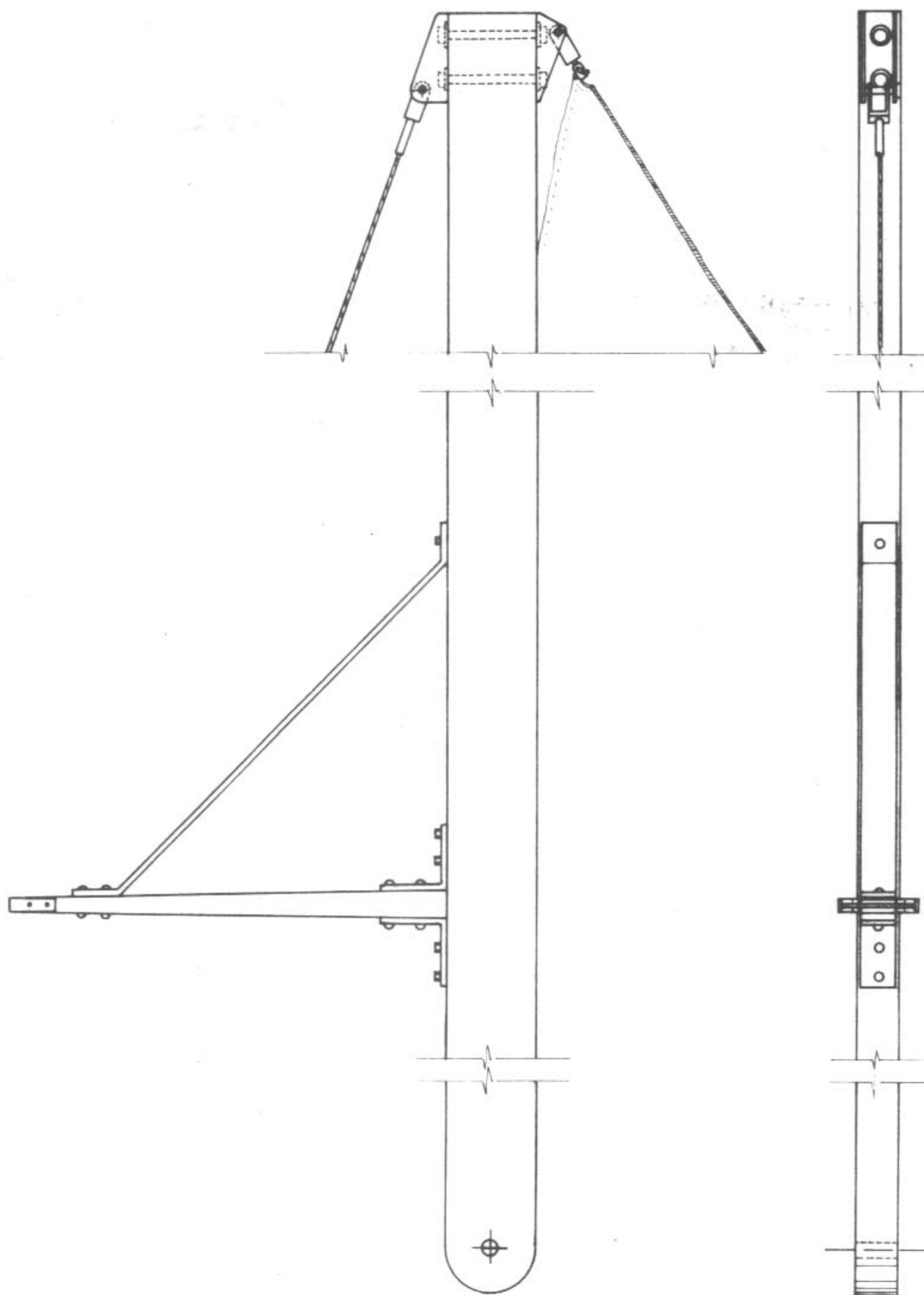
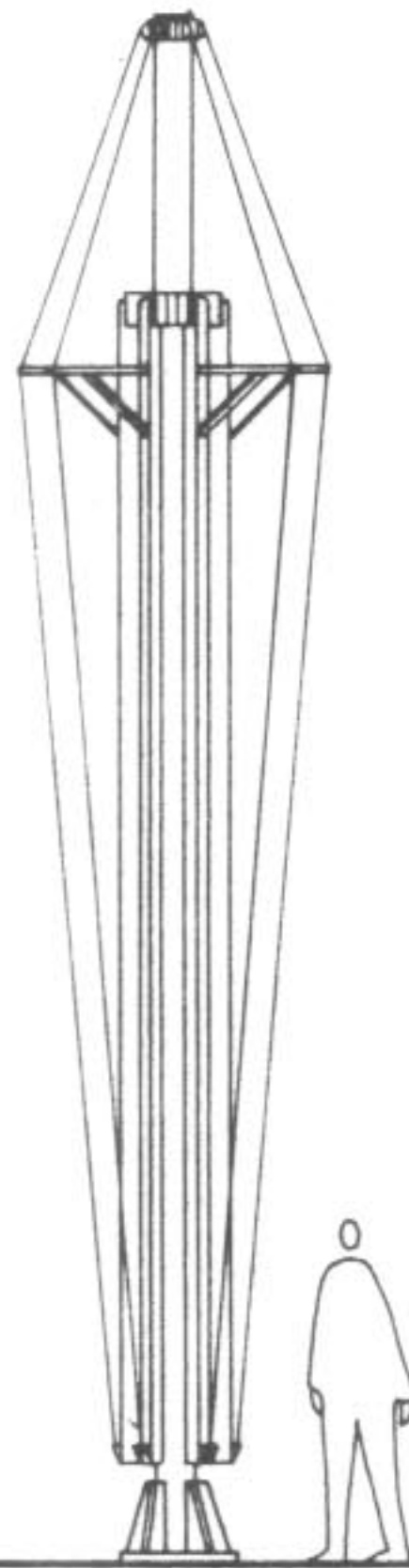

Figure 74

10 20 cm

1



2

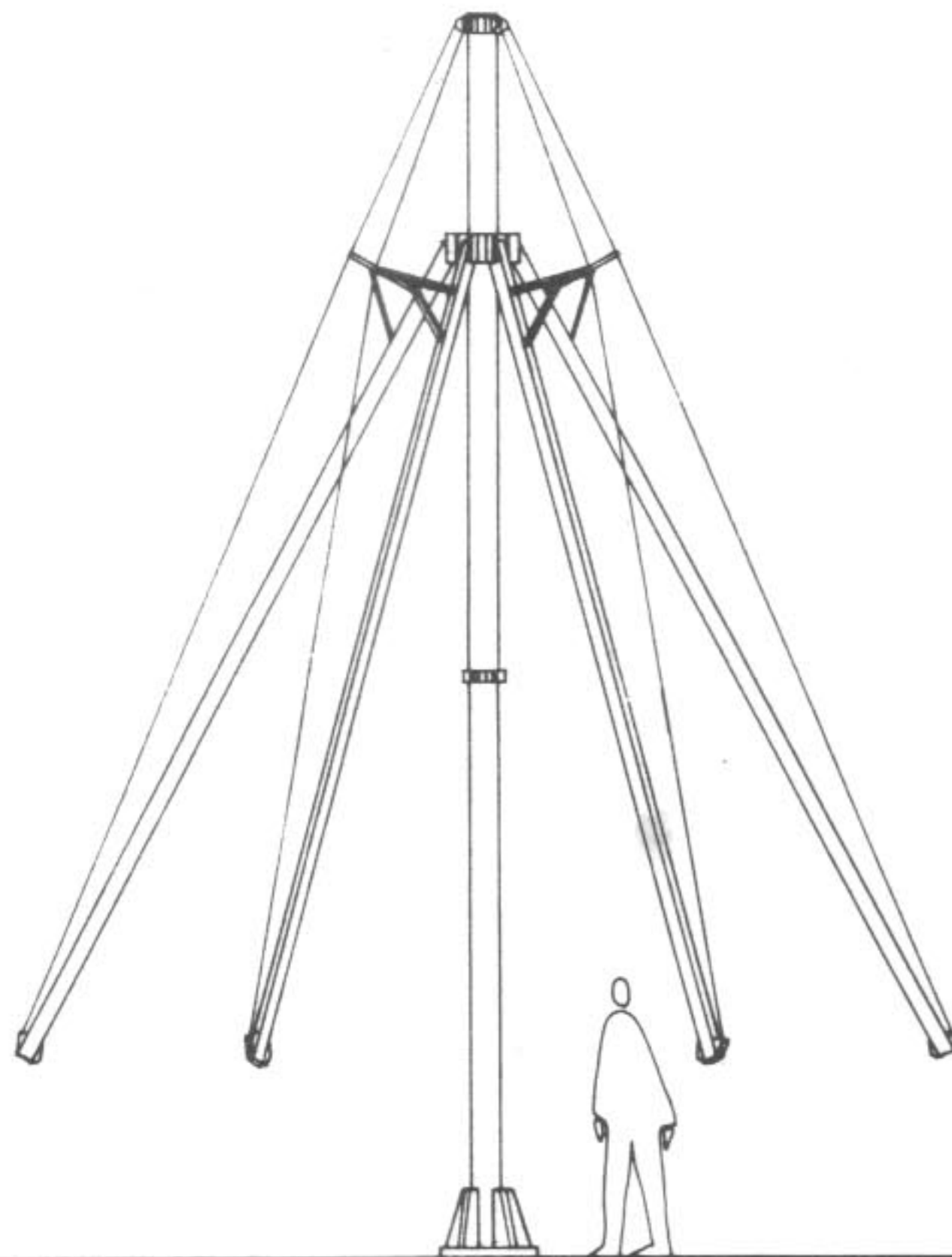
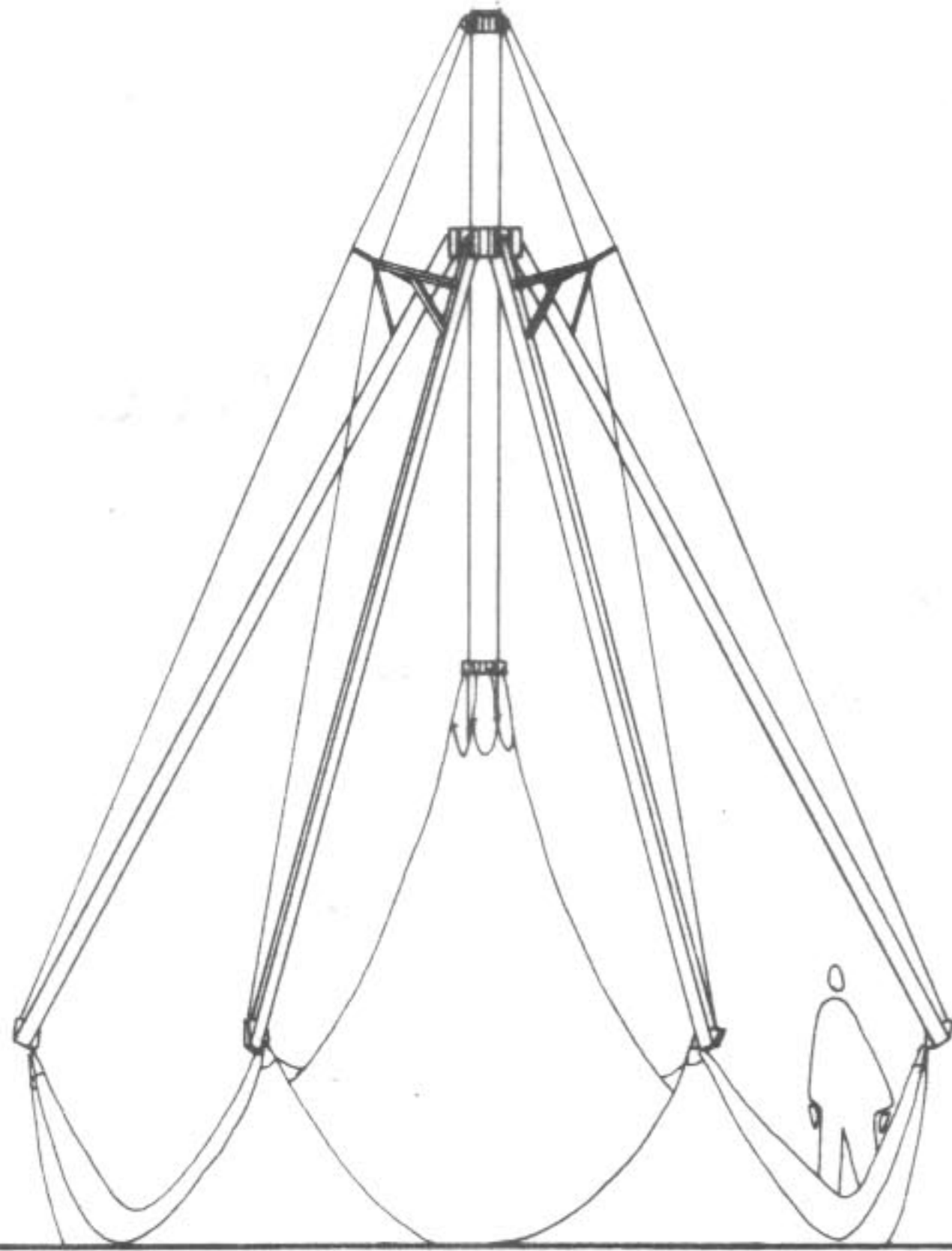

Figure 75

Assembly Sequence

3



4

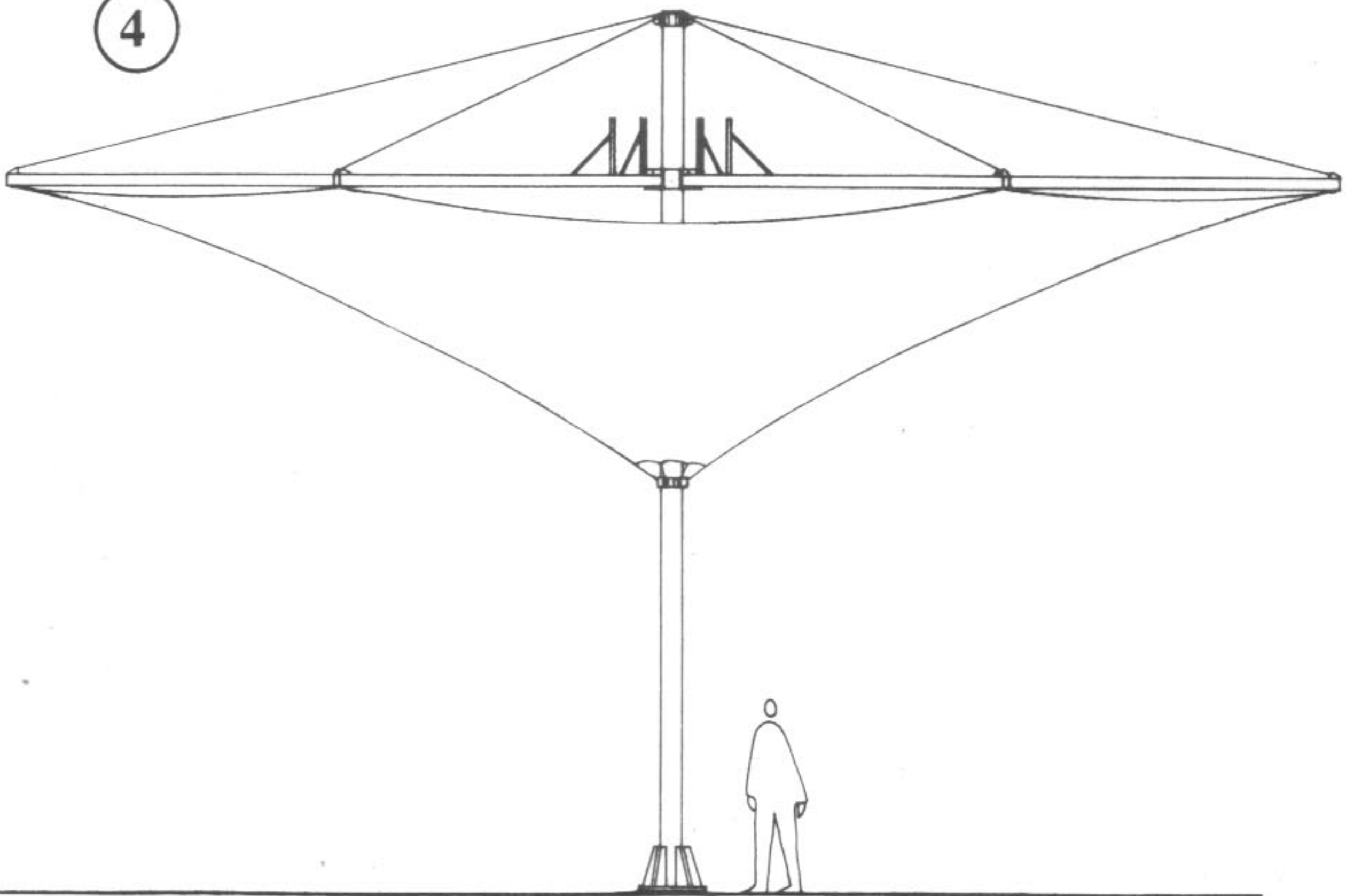

Figure 75

Assembly Sequence

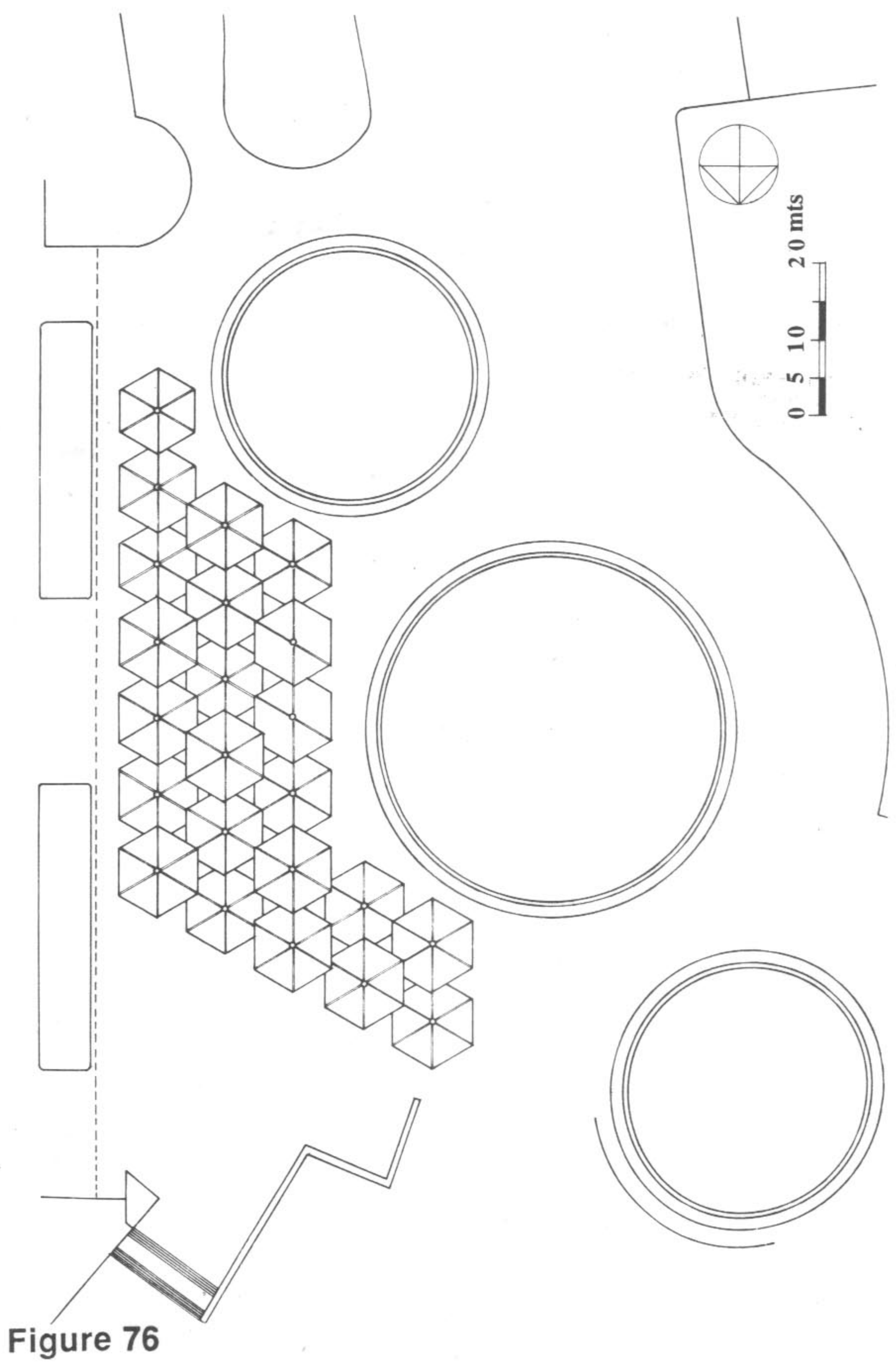

Figure 76

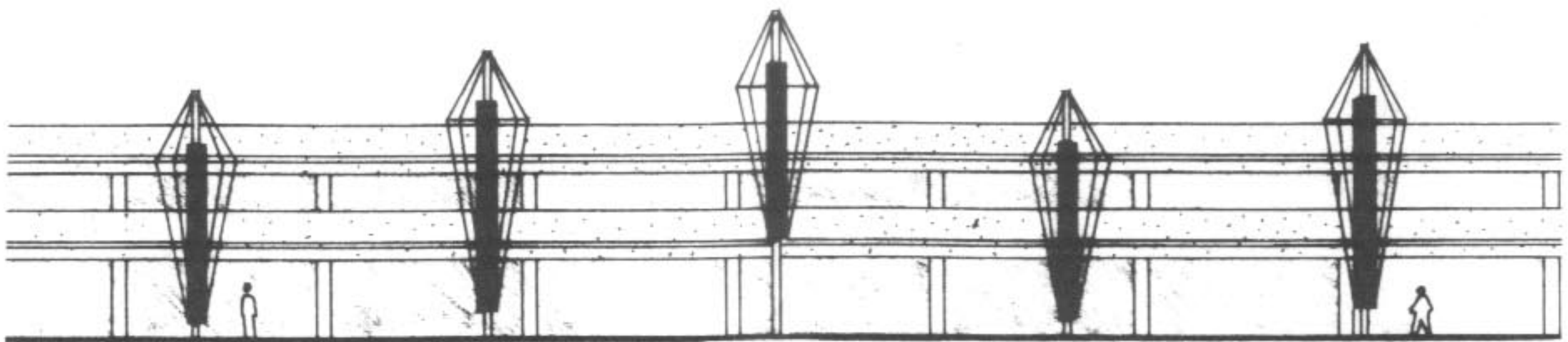
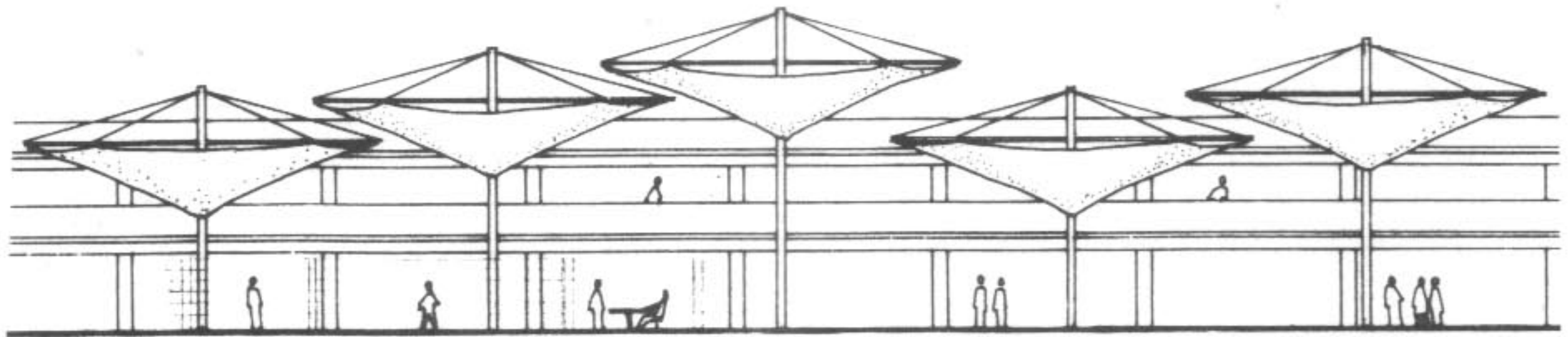

Figure 77

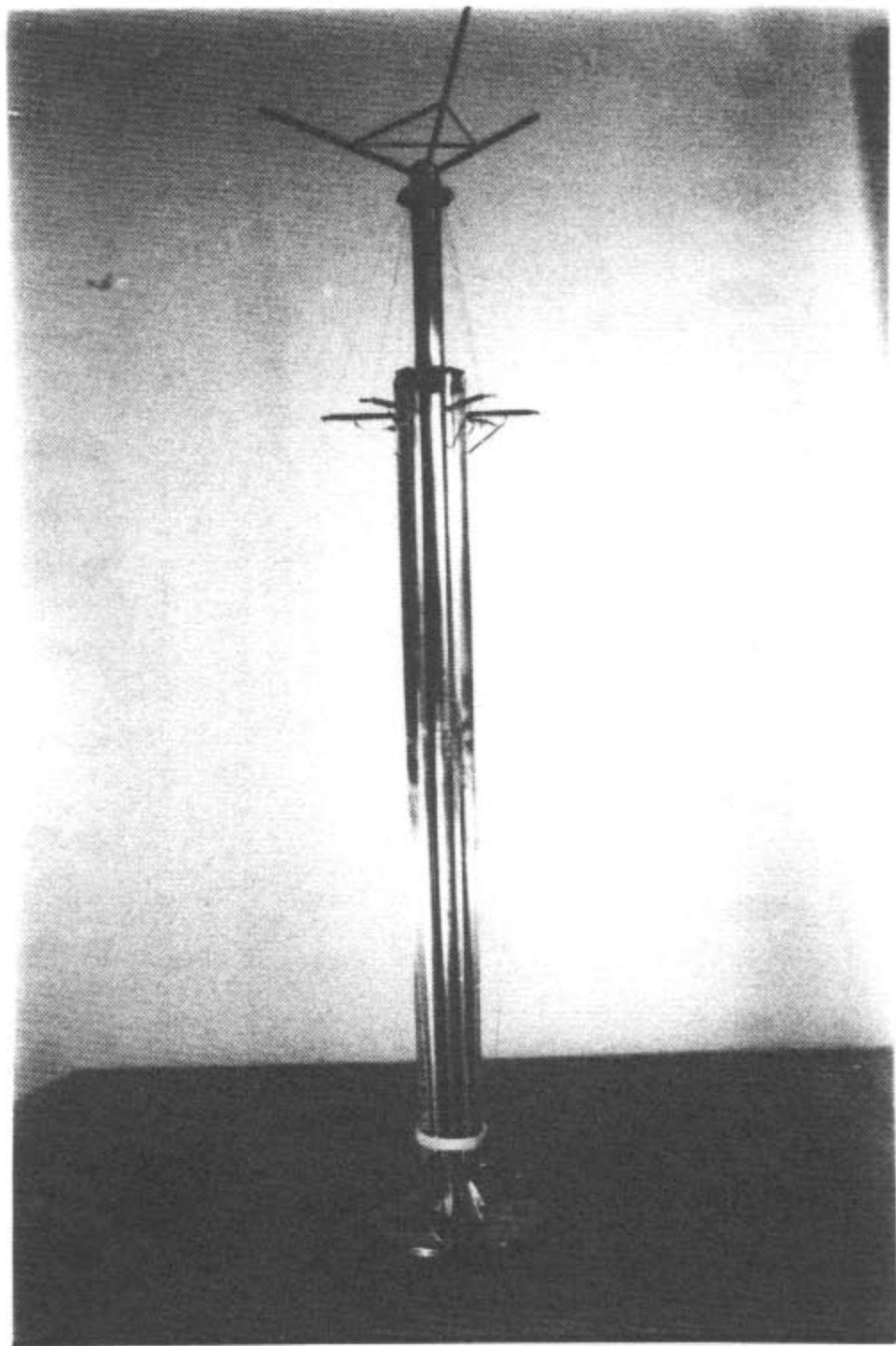

Figure 79

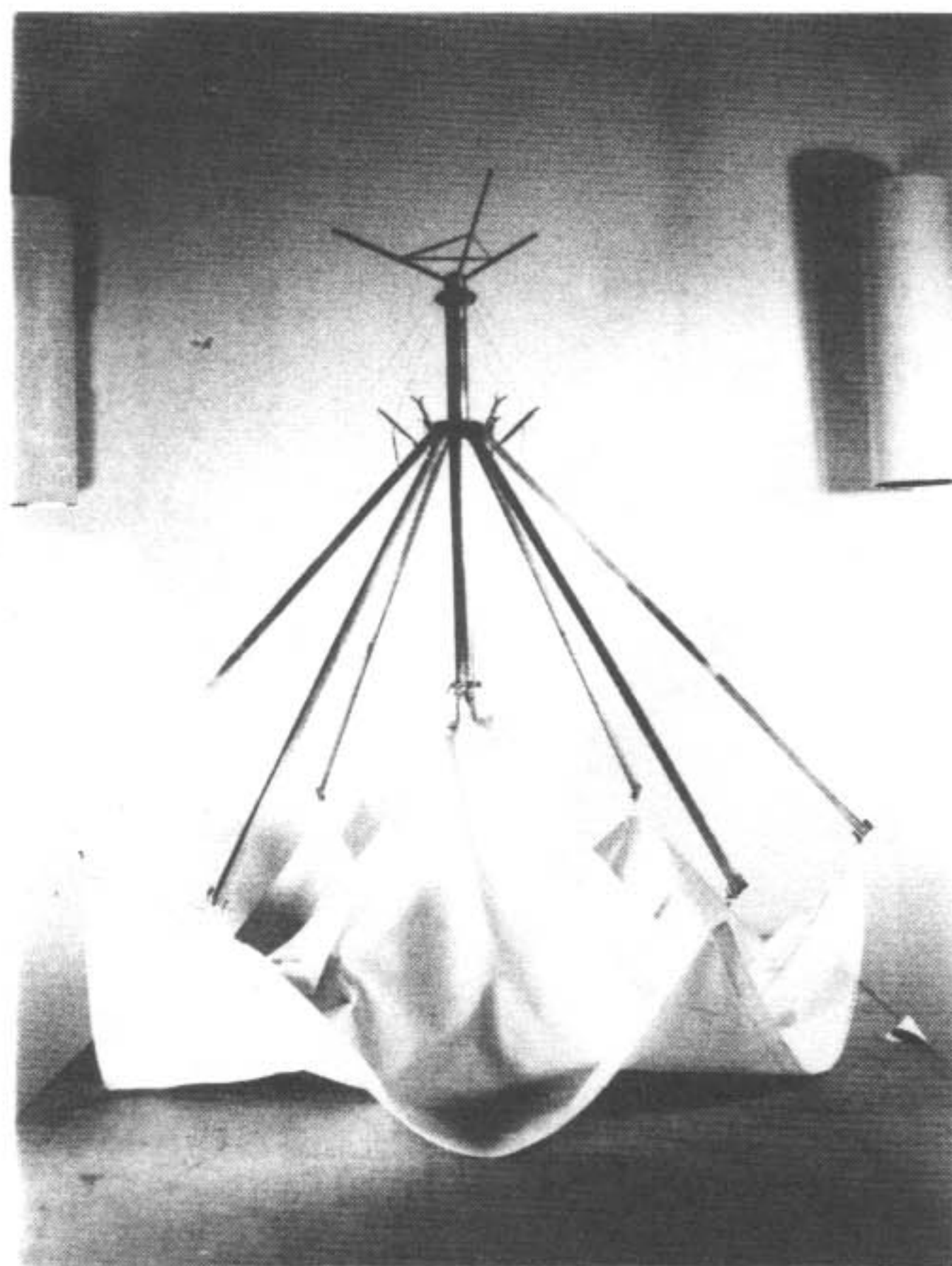
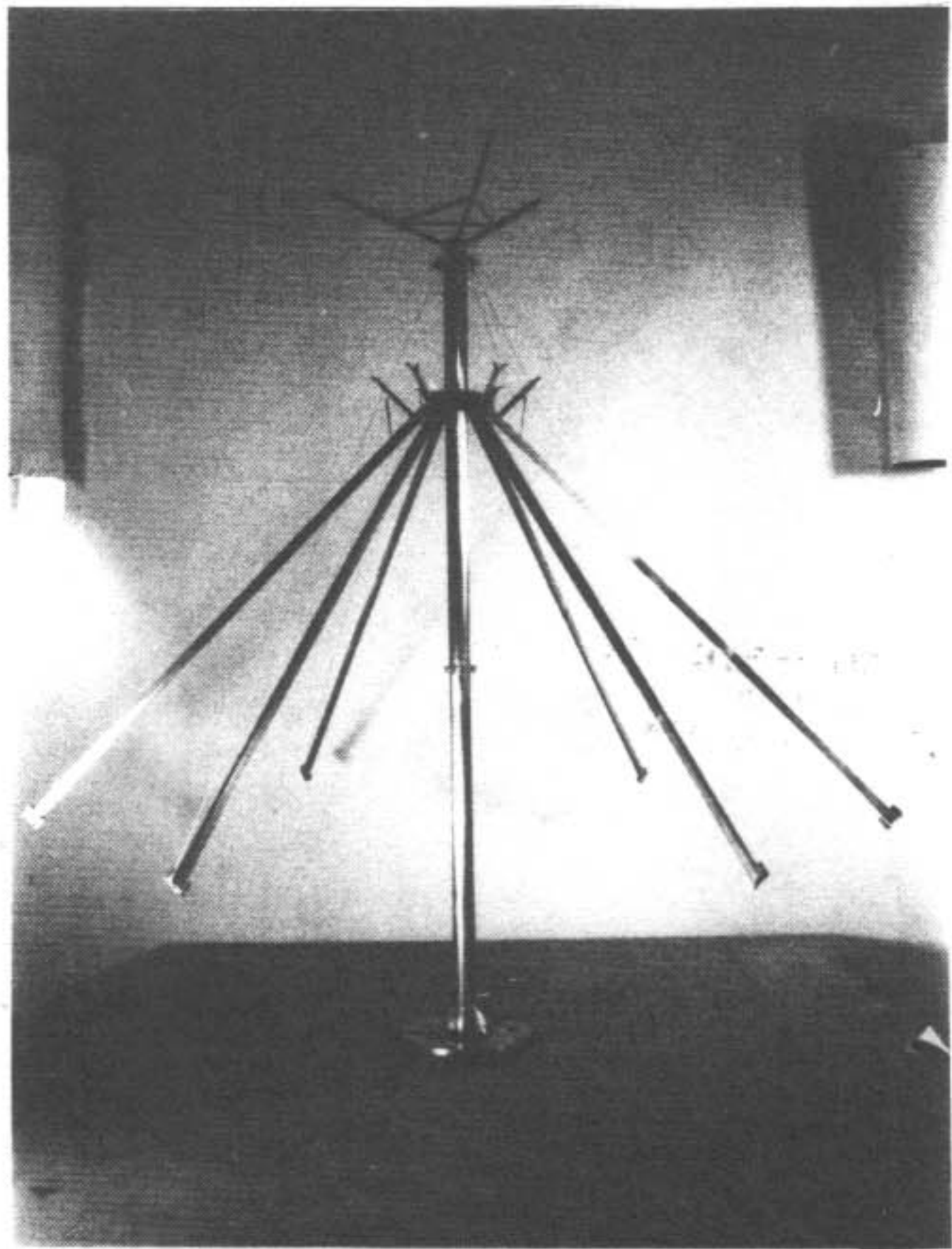

Figure 78

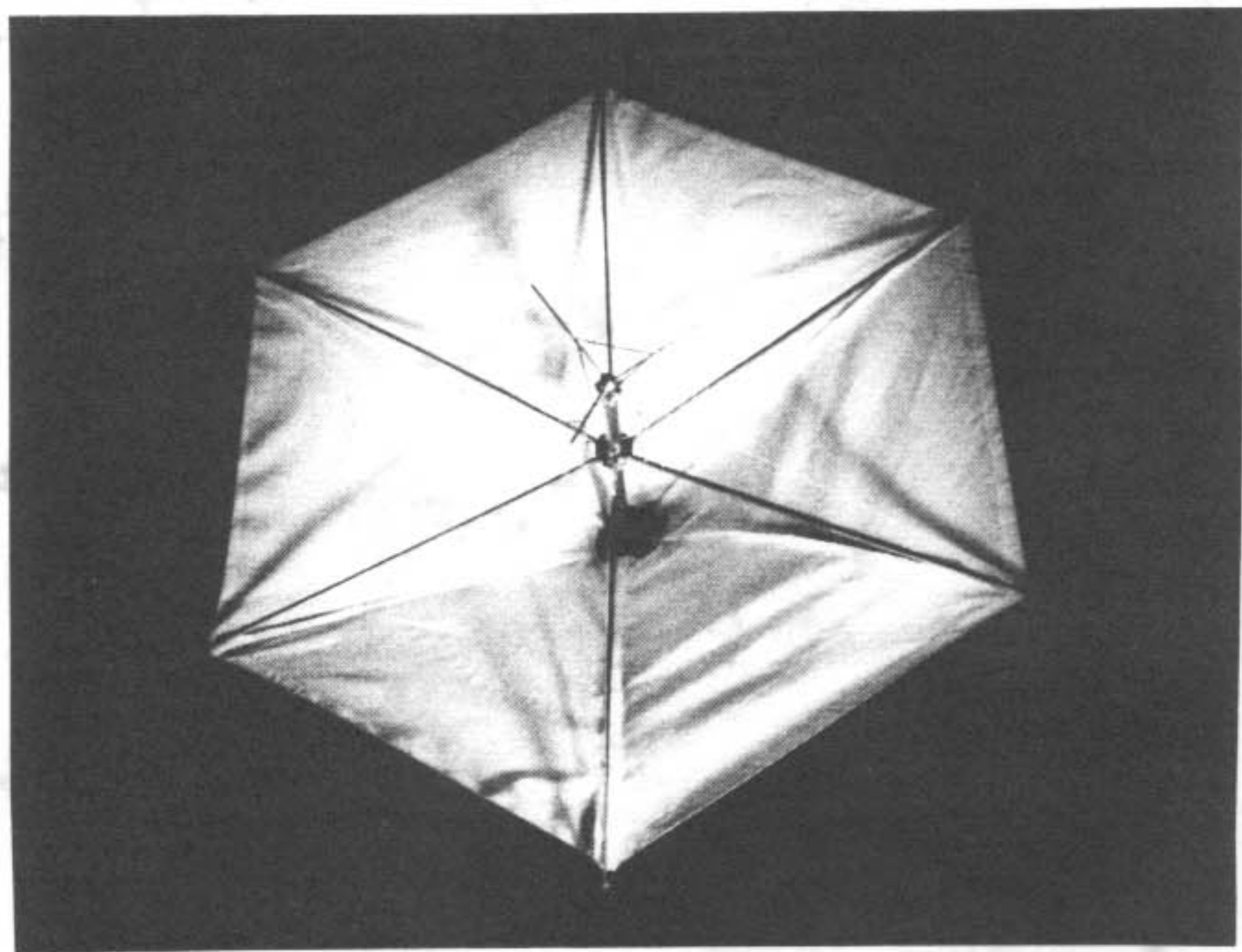
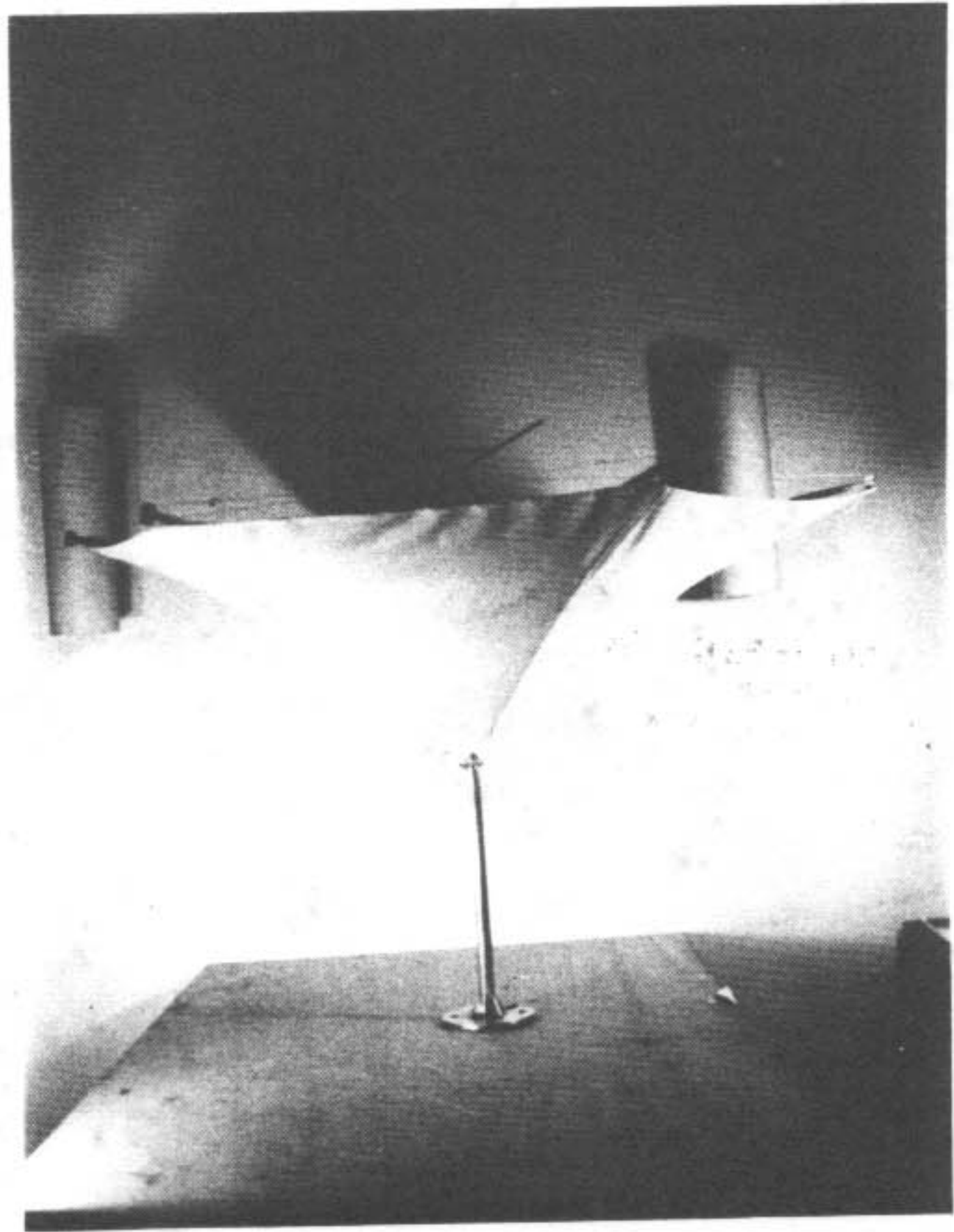

Figure 80